

Brushless Motor Parameter Optimization Report

Spring 2011

May 6, 2011

Alicia Violeta Juarez Crow

ECE 2012

1439 Kentfield Ave. Apt. 2

Redwood City, CA 94061

(650)395-7846

avj22@cornell.edu

ECE 4999 Final Report

3 credits

Biorobotics and Locomotion Lab
Cornell University

Table of Contents

I. Introduction.....	3
II. Methods and Results	Error! Bookmark not defined.
A. Test 1.....	Error! Bookmark not defined.
B. Test 4.....	Error! Bookmark not defined.
C. Test 5.....	5
D. Test 6.....	Error! Bookmark not defined.
E. Test 7.....	Error! Bookmark not defined.
F. Test 8.....	Error! Bookmark not defined.
G. Test 9.....	Error! Bookmark not defined.
H. Test 10.....	Error! Bookmark not defined.
I. Test 11.....	Error! Bookmark not defined.
III. Conclusion	Error! Bookmark not defined.
IV. Citations.....	6
V. Appendices	7
A. Motor	7
B. Motor controller board.....	8
C. Test 1.....	8
D. Test 4.....	10
E. Test 5.....	11
F. Test 6.....	13
G. Test 7.....	14
H. Test 8.....	14
I. Test 9.....	15
J. Test 10.....	18
K. Test 11.....	19
L. Test 11b.....	24

I. Introduction

Given the currently available means to actuate robots, it is a challenge to design efficient robots without sacrificing functionality. A walking robot, for example, should draw the least amount of power possible while walking normally, but it should be able to draw the necessary amount of power to catch itself if it needs to.

Evidence suggests that brushless motors, despite being difficult to control, have a number of advantages over brushed motors. One of the reasons is that brushless motors can run longer at higher power because the electromagnets in the stator are easier to cool than those in the rotor of a brushed motor (Clementi 3). Another disadvantage of brushed motors, explained by Jason Cortell, is that “the noise and voltage drop across the brushes of a brushed motor wastes power and makes current control in the rotor more challenging”. The motor used for this project was the Maxon EC-powermax, 22mm, brushless, 90 Watt, order number 311536, which had been previously selected. Technical information can be found in the Appendix A.

The purpose of this series of tests was to help design a controller for the selected motor by finding optimum parameters for the motor in different regions of operation while having a design that is efficient, light, and provides the necessary amount of power. PWM frequency and series inductance are the main parameters to consider. Adding inductance can reduce power loss if a certain amount of current is being drawn. However, this adds weight and volume to the robot.

The motor controller board used to conduct most of the tests was built by Brian Clementi. Appendix B contains figures and diagrams that depict the setup of the board.

For more detailed information on the controller refer to "Brushless Motor Controller Report", Spring 2010.

Controlling the speed of the motor with constant voltage would make the system heat up and this would result in power loss. Several options for driving a brushless motor are described in the Shane Colton's Thesis. The two main methods described are sinusoidal wave drive and square wave drive, also known as six-step drive. Which one to use usually depends on the shape of the back EMF wave of the motor.

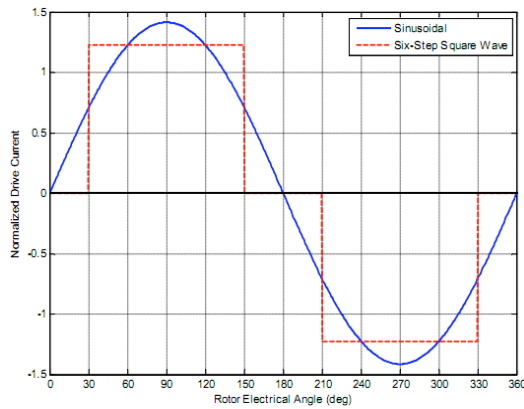

Figure 1 Sinusoidal and Square Wave drive waveforms (Colton 17)

Colton analyzes two ideal cases: sinusoidal back EMF with sinusoidal drive, which is considered AC, and trapezoidal back EMF with six-step drive, which is considered DC. The latter has the advantage of producing more torque per unit heat dissipation, theoretically ripple-free. However, when motor inductance is considered, sharp transitions in current are no longer possible and a rise and fall time appears. This leads to torque ripple and additional heat dissipation in the controller diodes.

The method used in this controller is Pulse Width Modulation (PWM). Ideally, the wave should be a square wave, as shorter transition time results in more efficiency. In

Violeta Crow 6/5/11 1:57 PM
Comment: Clementi's report is not very clear about why this was chosen

~ 4 ~

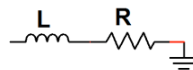

practice, as described in the previous paragraph, the transitions are gradual.

The motor can be modeled by an inductor-resistor circuit.

The power loss in the resistor is given by $P = I^2 R$ lowest at a frequency of about 100kHz.

A. Test 5

The objective of this test was to find the power consumed by the motor itself. This was done by measuring the current in the system, measuring the current in the motor controller board without a motor, and then subtracting them. The voltage was held at 29.6V. The PWM was varied from 5 to 590. A tachometer was used to measure the speed of the motor in revolutions per minute (RPM).

Violeta Crow 6/3/11 3:58 PM
Comment: Voltage of what?

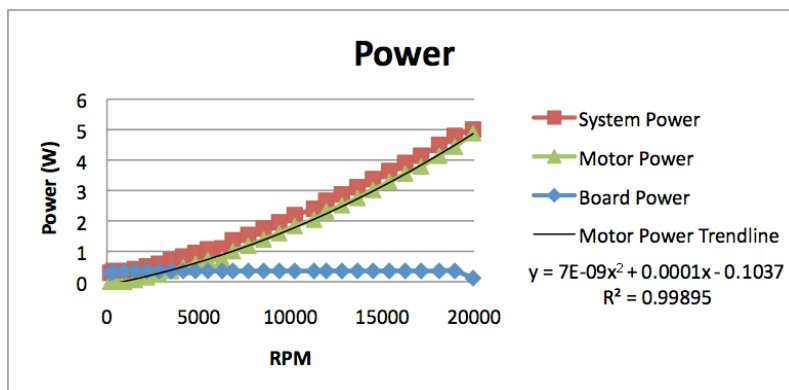

Figure 2 Comparison of power consumed by system, board, and motor

The blue line in the graph shows that the power consumed by the board was constant, except at high speeds, at which it suddenly decreased.

Violeta Crow 6/3/11 4:01 PM
Comment: Why?

The equation obtained from the trend line of the power consumption of the motor was $P = I^2 R$ need modifications to be able to perform the necessary adjustments. Further experimentation should be done as the design of the final motor controller progresses.

II. Citations

Clementi, Brian. "Brushless Motor Controller Report." MAE 4900 Final Report. Cornell University, 2010.

Colton, Shane W. "Design and Prototyping Methods for Brushless Motors." Master of Science Thesis. Massachusetts Institute of Technology, 2010.

Cortell, Jason. "Lab Report Edits and Additions." Message to the author. 28 May 2011. E-mail.

III. Appendices

A. Motor

Maxon EC-powermax, 22mm, brushless, 90 Watt, order number 311536

Motor data		
Assigned power rating	W	120
Nominal voltage	V	24
No load speed	min ⁻¹	16800
Stall torque	mNm	990
Max. continuous torque	mNm	54.3
Speed / torque gradient	min ⁻¹ / mNm ⁻¹	17.1
No load current	mA	406
Starting current	A	73.1
Max. permissible speed	min ⁻¹	25000
Nominal current (max. continuous current)	A	4.36
Max. efficiency	%	86
Torque constant	mNm / A ⁻¹	13.5
Speed constant	min ⁻¹ / V ⁻¹	705
Mechanical time constant	ms	1.59
Rotor inertia	gcm ²	8.91
Terminal inductance	mH	30.8
Thermal resistance housing-ambient	KW ⁻¹	8.01
Thermal resistance winding-housing	KW ⁻¹	1
Thermal time constant winding	s	6.4
Motor length	mm	66
Weight	g	175



B. Motor controller board

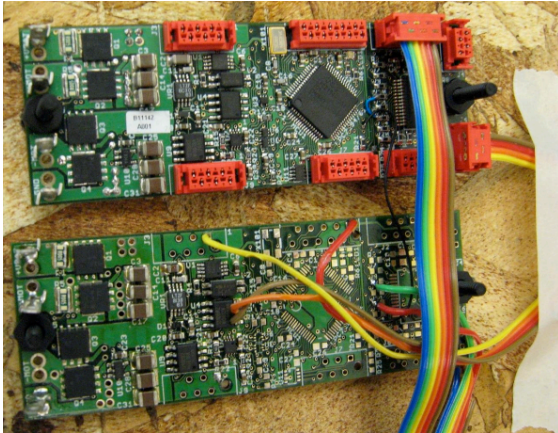

Figure 3 Brushless Motor Controller
Composed of pseudo-controller (bottom) and original controller (top)

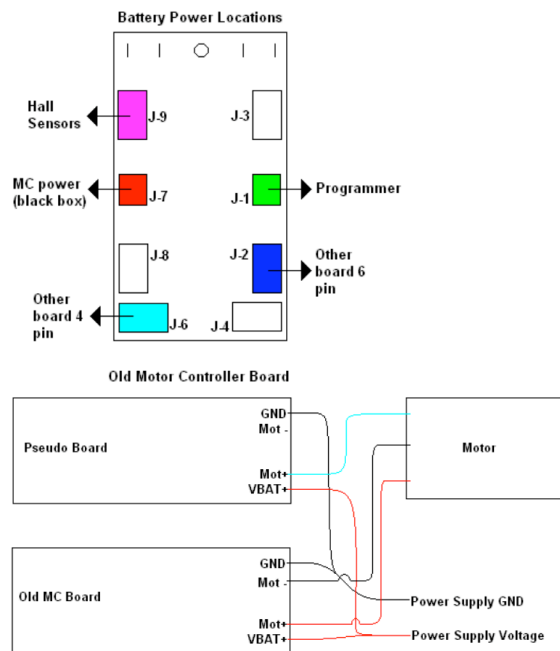

Figure 4 Motor controller board setup

C. Test 1

- Date: February 2, 2011

- Materials used:
 - Tektronix CFC250, 100MHz Frequency Counter
 - Regulator Power supply. Model LCS-A-01
 - CIC Ps-1930, DC Power Supply
 - FLUKE True RMS Multimeter
 - Motor: Maxon EC-powermax, 22mm, bluishless, 90 Watt, order number 311536
 - Brushless motor controller
- Controlled variables: PWM and voltage
- Dependent variables: Current and Frequency

PWM = 50

Voltage (V)	Current(A)	Frequency(Hz)	RPM
10	0.02	10	600
12	0.02	12	720
12.5	0.02	12	720
14	0.02	14	840
15	0.02	14	840
16	0.02	16	960
17.5	0.02	17	1020
19	0.02	21	1260
20	0.03	20	1200
22.5	0.03	23	1380
25	0.03	25	1500

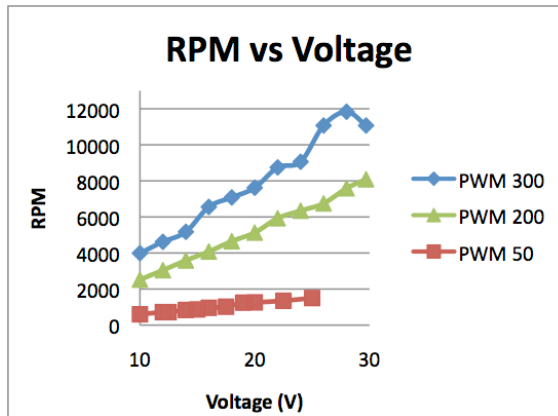

PWM = 200

Voltage (V)	Current(A)	Frequency(Hz)	RPM
10	0.07	43	2580
12	0.08	51	3060
14	0.09	59	3540
16	0.1	67	4020
18	0.11	79	4740
20	0.115	86	5160
22	0.12	97.5	5850
24	0.13	104	6240
26	0.14	107	6420
28	0.145	126	7560
29.7	0.15	135.5	8130

PWM = 500

Voltage (V)	Current(A)	Frequency(Hz)	RPM
10	0.11	70	4200

12	0.12	74	4440
14	0.13	87.5	5250
16	0.14	107.5	6450
18	0.15	112	6720
20	0.16	129	7740
22	0.17	139.5	8370
24	0.18	150	9000
26	0.19	178	10680
28	0.2	200.5	12030
29.7	0.21	184	11040

D. Test 4

- Date: February 23, 2011
- Materials used:
 - Regulator Power supply. Model LCS-A-01
 - CIC Ps-1930, DC Power Supply
 - FLUKE True RMS Multimeter
 - Motor: Maxon EC-powermax, 22mm, blushless, 90 Watt, order number 311536
 - Brushless motor controller
- Controlled variables: PWM
- Dependent variables: Current

Current (A)			
Frequency (kHz)	All inductors connected	One inductor shorted	Two inductors shorted
20	0.048	-	-
50	0.024	0.046	-
60	0.023	0.041	-
80	0.022	0.037	-
100	0.022	0.035	-
120	0.023	0.034	0.117
150	0.024	0.033	-
200	0.027	0.035	0.107
300	0.036	0.041	0.098
400	0.045	0.049	0.096
500	-	0.057	0.098
600	-	0.067	0.101

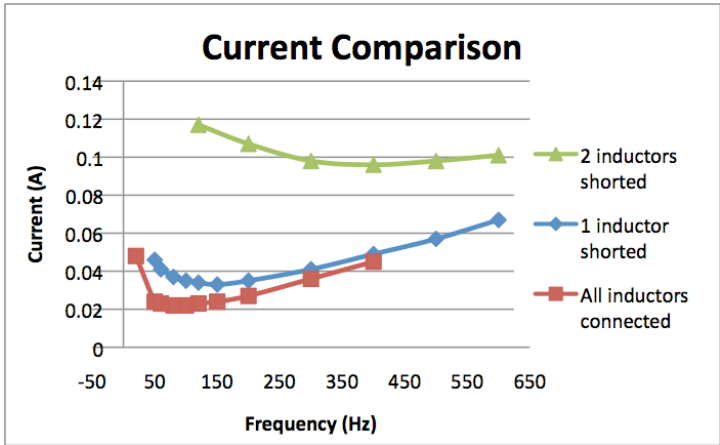

E. Test 5

- Date: February 23, 2011
- Materials used:
 - Regulator Power supply. Model LCS-A-01
 - CIC Ps-1930, DC Power Supply
 - FLUKE True RMS Multimeter
 - Motor: Maxon EC-powermax, 22mm, brushless, 90 Watt, order number 311536
 - Brushless motor controller
- Controlled variables: PWM
- Dependent variables: Current and speed

PWM	RPM	System Current (A)	Board current (A)	Motor current (A)	Motor Power (W)
5	183	0.01	0.01	0	0
10	352	0.012	0.011	0.001	0.0296
20	934	0.012	0.012	0	0
40	1520	0.014	0.012	0.002	0.0592
60	2173	0.017	0.012	0.005	0.148
80	2834	0.02	0.012	0.008	0.2368
100	3490	0.024	0.012	0.012	0.3552
120	4150	0.028	0.012	0.016	0.4736
140	4820	0.032	0.012	0.02	0.592
160	5497	0.036	0.012	0.024	0.7104
180	6277	0.037	0.012	0.025	0.74
200	6854	0.046	0.012	0.034	1.0064

225	7700	0.052	0.012	0.04	1.184
250	8536	0.059	0.012	0.047	1.3912
275	9385	0.066	0.012	0.054	1.5984
300	10226	0.074	0.012	0.062	1.8352
325	11280	0.081	0.012	0.069	2.0424
350	11945	0.09	0.012	0.078	2.3088
375	12798	0.097	0.012	0.085	2.516
400	13648	0.105	0.012	0.093	2.7528
425	14493	0.114	0.012	0.102	3.0192
450	15379	0.123	0.012	0.111	3.2856
475	16245	0.132	0.012	0.12	3.552
500	17111	0.14	0.012	0.128	3.7888
530	18098	0.152	0.012	0.14	4.144
560	18945	0.162	0.012	0.15	4.44
590	19943	0.169	0.004	0.165	4.884

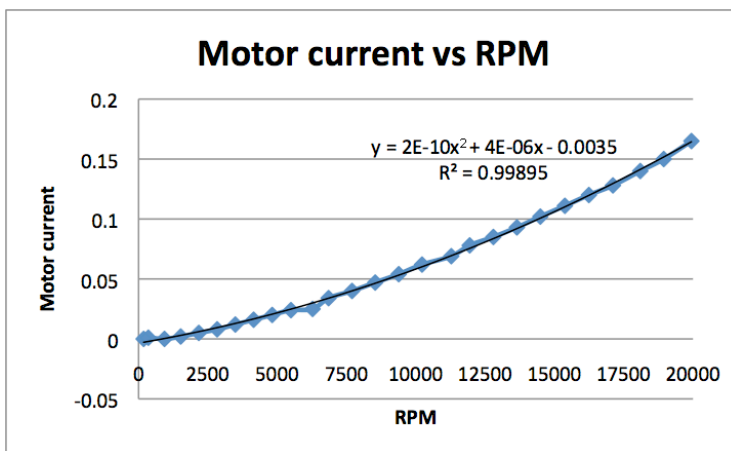

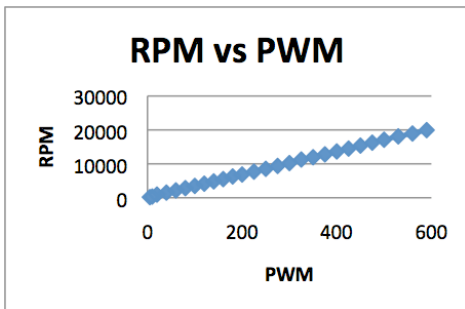
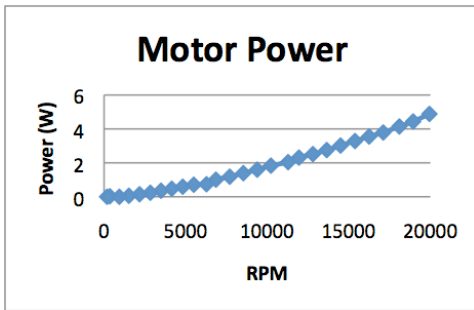

F. Test 6

- Date: March 9, 2011
- Materials used:
 - Regulator Power supply. Model LCS-A-01
 - CIC Ps-1930, DC Power Supply
 - FLUKE True RMS Multimeter
 - Brushless motor controller
- Controlled variables: PWM
- Dependent variables: Current

Frequency (kHz)	Current (A)			
	No motor	All inductors connected	One inductor shorted	Two inductors shorted
50	0.01	0.014	0.036	-
60	0.011	0.012	0.03	-
80	0.013	0.009	0.024	-
100	0.016	0.006	0.019	-
120	0.018	0.005	0.016	0.099

150	0.022	0.002	0.011	-
200	0.028	-0.001	0.007	0.079
300	0.04	-0.004	0.001	0.058
400	0.051	-0.006	-0.002	0.045
500	0.063	-	-0.006	0.035
600	0.076	-	-0.009	0.025

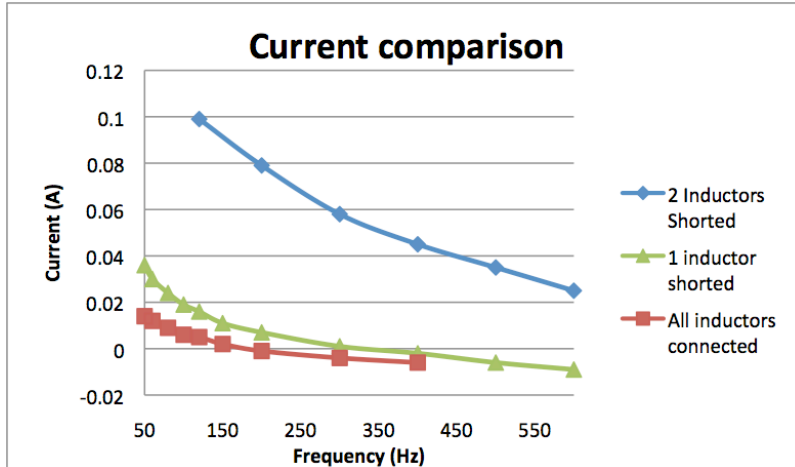

G. Test 7

- Date: March 11, 2011
- Materials used:
 - Regulator Power supply. Model LCS-A-01
 - CIC Ps-1930, DC Power Supply
 - FLUKE True RMS Multimeter
 - Brushless motor controller
- Controlled variables: PWM
- Dependent variables: Current

	Voltage (V)	PWM	Current (A)
Normal test	24	586	0.154
Pipe over it	24	586	0.157

H. Test 8

- Date: March 9, 2011

- Materials used:
 - Regulator Power supply. Model LCS-A-01
 - CIC Ps-1930, DC Power Supply
 - FLUKE True RMS Multimeter
 - Brushless motor controller
- Controlled variables: PWM
- Dependent variables: Current

Current (A)		
Frequency (kHz)	All inductors connected	All inductors (Test 6)
50	0.016	0.014
60	0.012	0.012
80	0.009	0.009
100	0.006	0.006
120	0.004	0.005
150	0.002	0.002
200	-0.001	-0.001
300	-0.005	-0.004
400	-0.006	-0.006

I. Test 9

- Date: March 18, 2011
- Materials used:
 - Regulator Power supply. Model LCS-A-01
 - CIC Ps-1930, DC Power Supply
 - FLUKE True RMS Multimeter
 - BK Toolkit 2704B Multimeter
 - AM 503 Current Probe Amplifier
 - Motor: Maxon EC-powermax, 22mm, blushless, 90 Watt, order number 311536
 - 47 μ H inductors (3)
 - Brushless motor controller
- Controlled variables: PWM
- Dependent variables: Current

No Motor Connected (Trial 1)				
PWM	Frequency (kHz)	Current (A)	File name	RMS ripple current
1200	50	0.008	13	0.034348

1000	60	0.009	14	0.035003
750	80	0.012	15	0.034677
600	100	0.014	16	0.035525
500	120	0.017	17	0.035158
400	150	0.02	18	0.038042
300	200	0.027	19	0.038643
200	300	0.039	20	0.039041
150	400	0.051	21	0.043329
120	500	0.063	22	0.042276
100	600	0.075	23	0.043449

No Motor Connected (Trial 2)

PWM	Frequency (kHz)	Current (A)	File name	RMS ripple current
1200	50	0.008	57	0.034249
1000	60	0.009	58	0.033876
750	80	0.012	59	0.03339
600	100	0.014	60	0.034001
500	120	0.017	61	0.034448
400	150	0.02	62	0.034393
300	200	0.026	63	0.033761
200	300	0.038	64	0.033594
150	400	0.05	65	0.034172
120	500	0.062	66	0.03553
100	600	0.074	67	0.035448

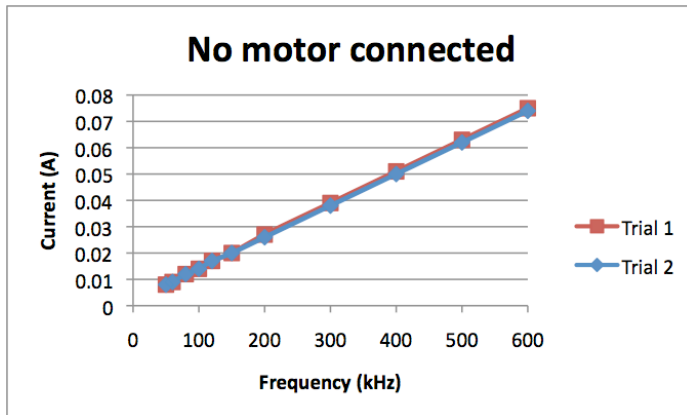

All Inductors Shorted

PWM	Frequency (kHz)	Current (A)	File name	Board Current	Motor Current	RMS ripple current
1200	50	0.315	ALL001	0.008	0.307	0.89003

1000	60	0.285	ALL002	0.009	0.276	0.847195
750	80	0.242	ALL003	0.012	0.23	0.685954
600	100	0.213	ALL004	0.014	0.199	0.580594
500	120	0.192	ALL005	0.017	0.175	0.505113
400	150	0.17	ALL006	0.02	0.15	0.4362
300	200	0.147	ALL007	0.027	0.12	0.343003
200	300	0.126	ALL008	0.039	0.087	0.255333
150	400	0.117	ALL010	0.051	0.066	0.2084
120	500	0.115	ALL011	0.063	0.052	0.177751
100	600	0.116	ALL012	0.075	0.041	0.155089

Two inductors in parallel

PWM	Frequency (kHz)	Current (A)	File name	Board Current	Motor Current	RMS ripple current
1200	50	0.101	24	0.008	0.093	0.495382842
1000	60	0.09	25	0.009	0.081	0.457676917
750	80	0.075	26	0.012	0.063	0.358961168
600	100	0.065	27	0.014	0.051	0.296708342
500	120	0.059	28	0.017	0.042	0.252909154
400	150	0.053	29	0.02	0.033	0.212623611
300	200	0.049	30	0.027	0.022	0.164418004
200	300	0.05	31	0.039	0.011	0.118333089
150	400	0.054	32	0.051	0.003	0.097417042
120	500	0.062	33	0.063	-0.001	0.08418931
100	600	0.07	34	0.075	-0.005	0.07306326

One Inductor

PWM	Frequency (kHz)	Current (A)	File name	Board Current	Motor Current	RMS ripple current
1200	50	0.056	35	0.008	0.048	0.336401902
1000	60	0.049	36	0.009	0.04	0.307357512
750	80	0.042	37	0.012	0.03	0.240401664
600	100	0.037	38	0.014	0.023	0.200179519
500	120	0.035	39	0.017	0.018	0.168229843
400	150	0.034	40	0.02	0.014	0.139100539
300	200	0.034	41	0.027	0.007	0.110307933
200	300	0.04	42	0.039	0.001	0.080302428
150	400	0.048	43	0.051	-0.003	0.07006968
120	500	0.057	44	0.063	-0.006	0.06145958
100	600	0.066	45	0.075	-0.009	0.057209789

All Inductors Connected

PWM	Frequency (kHz)	Current (A)	File name	Board Current	Motor Current	RMS ripple current
-----	-----------------	-------------	-----------	---------------	---------------	--------------------

1200	50	0.028	46	0.008	0.02	0.21343922
1000	60	0.026	47	0.009	0.017	0.195873984
750	80	0.024	48	0.012	0.012	0.151681688
600	100	0.023	49	0.014	0.009	0.124619562
500	120	0.023	50	0.017	0.006	0.106077949
400	150	0.024	51	0.02	0.004	0.089928256
300	200	0.027	52	0.027	0	0.07281424
200	300	0.035	53	0.039	-0.004	0.057207104
150	400	0.045	54	0.051	-0.006	0.051056298
120	500	0.055	55	0.063	-0.008	0.044378878
100	600	0.067	56	0.075	-0.008	0.043528084

*File Name refers to the name of the excel spreadsheet generated by the oscilloscope.

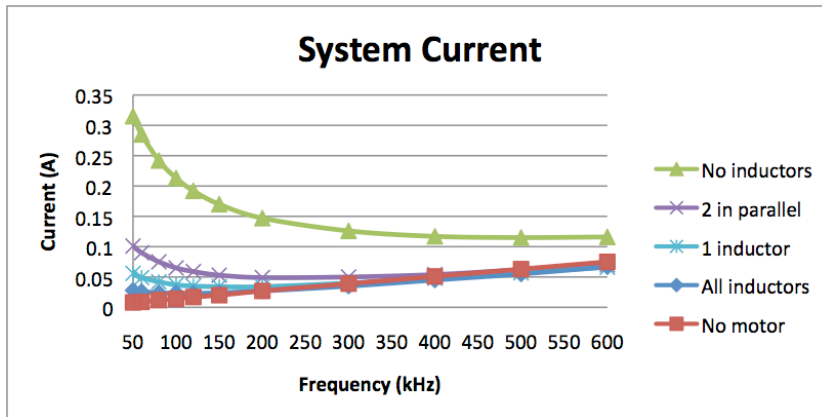

J. Test 10

- Date: March 22, 2011
- Materials used:
 - Precision LCR meter: 4284A Agilent 20kHz-1MHz
 - Motor: Maxon EC-powermax, 22mm, brushless, 90 Watt, order number 311536
 - 47 μ H inductor
- Controlled variables: Frequency
- Dependent variables: Series inductance and series resistance

Motor		
Frequency (kHz)	Ls (μ H)	Rs (Ohms)

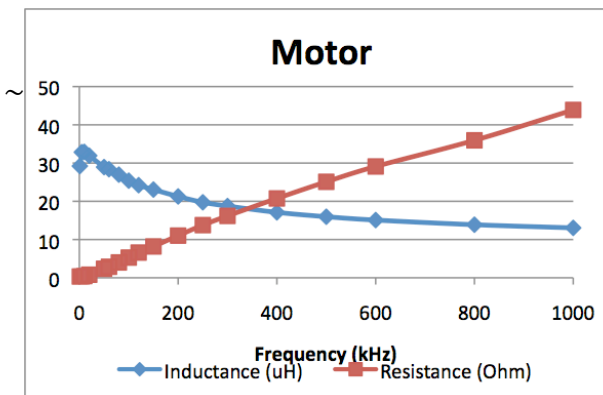

1	29.22	0.332
5	32.85	0.361
10	32.93	0.456
20	31.94	0.801
50	28.95	2.36
60	28.4	2.88
80	26.98	4.01
100	25.4	5.28
120	24.22	6.59
150	23.07	8.19
200	21.27	11.03
250	19.74	13.77
300	18.76	16.18
400	17.11	20.75
500	15.97	25.1
600	15.09	29.11
800	13.88	35.95
1000	13.05	43.9

Inductor		
Frequency (kHz)	Ls (μH)	Rs (Ohms)
1	52.92	0.078
5	52.65	0.107
10	52.7	0.162
20	52.32	0.296
50	51.84	0.76
60	52.27	0.693
80	51.99	0.9
100	51.37	1.33
120	51.35	1.56
150	51.22	1.85
200	51.08	2.48
250	50.82	3.22
300	50.8	3.87
400	50.68	5.3
500	50.75	6.93
600	50.94	8.63
800	51.71	11.5
1000	52.94	16.6

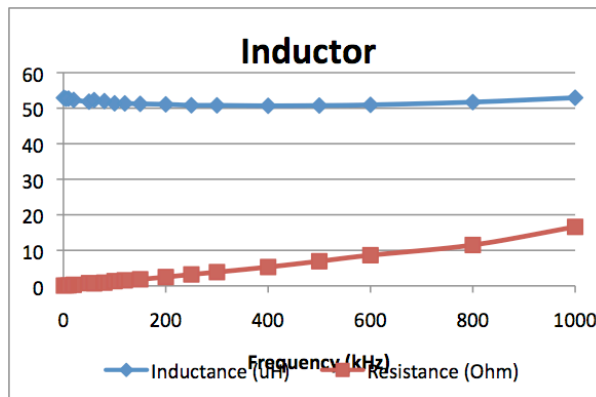

K. Test 11

- Date: March 29, 2011

- Materials used:
 - LabView simulation programmed by Jason Cortell
- Controlled variables: Frequency, Motor speed
- Dependent variables: Motor Electrical loss, RMS motor current

No Inductor							
Motor Speed (rad/s)	Frequency (kHz)	Inductance (uH)	Resistance (Ohm)	RMS motor current (A)	Motor electrical loss (W)	Average motor Current (A)	Duty cycle
0	100	25.4	5.28	0.00087	4.05E-06	0.00075	1.00E-05
0	200	21.27	11.03	0.00089	8.75E-06	0.00072	1.00E-05
0	300	18.76	16.18	0.00094	1.43E-05	0.00074	1.00E-05
0	400	17.11	20.75	0.000997	2.06E-05	0.00077	1.00E-05
500	100	25.4	5.28	0.611	1.97E+00	0.00037	1.69E-01
500	200	21.27	11.03	0.357	1.40E+00	0.00018	1.69E-01
500	300	18.76	16.18	0.266	1.15E+00	0.00041	1.69E-01
500	400	17.11	20.75	0.217	9.77E-01	9.64E-05	1.69E-01
1000	100	25.4	5.28	0.968	4.94	6.01E-16	0.3375
1000	200	21.27	11.03	0.564	3.50E+00	0.00109	3.38E-01
1000	300	18.76	16.18	0.419	2.84E+00	8.34E-05	3.37E-01
1000	400	17.11	20.75	0.342	2.42E+00	1.90E-04	3.38E-01
1500	100	25.4	5.28	1.08	6.16	0.00037	0.5063
1500	200	21.27	11.03	0.628	4.35	-0.00016	0.5062
1500	300	18.76	16.18	0.467	3.53	-0.00024	0.5061
1500	400	17.11	20.75	0.381	3.01	0.000289	0.5061
2000	100	25.4	5.28	0.95	4.76	5.13E-16	0.675
2000	200	21.27	11.03	0.553	3.37	0.00145	0.6753
2000	300	18.76	16.18	0.412	2.74	0.00016	0.6749
2000	400	17.11	20.75	0.335	2.33	0.00038	0.6751

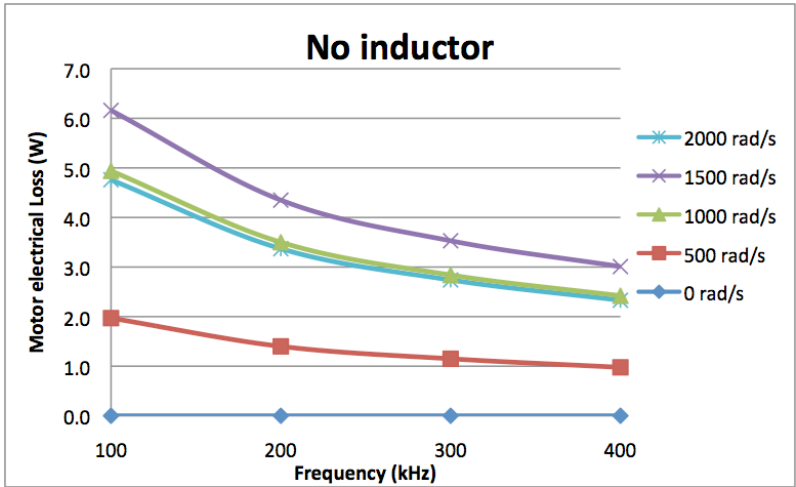

Half Inductor

Motor Speed (rad/s)	Frequency (kHz)	Inductance (uH)	Resistance (Ohm)	RMS motor current (A)	Motor electrical loss (W)	Average motor Current (A)	Duty cycle
0	100	51.085	5.945	0.0007	2.99E-06	0.00067	1.00E-05
0	200	46.81	12.27	0.00069	5.94E-06	0.00065	1.00E-05
0	300	44.16	18.115	0.00071	9.15E-06	0.00066	1.00E-05
0	400	42.45	23.4	0.00073	1.26E-05	0.00068	1.00E-05
500	100	51.085	5.945	0.313	5.82E-01	0.00168	1.69E-01
500	200	46.81	12.27	0.17	3.56E-01	0.00147	1.69E-01
500	300	44.16	18.115	0.12	2.62E-01	0.00103	1.69E-01
500	400	42.45	23.4	0.0936	2.05E-01	8.55E-05	1.69E-01
1000	100	51.085	5.945	0.497	1.47	6.30E-17	0.3375
1000	200	46.81	12.27	0.27	8.97E-01	0.00032	0.3375
1000	300	44.16	18.115	0.191	6.59E-01	7.45E-05	3.37E-01
1000	400	42.45	23.4	0.149	5.17E-01	-5.10E-04	3.37E-01
1500	100	51.085	5.945	0.556	1.84	0.00101	0.5064
1500	200	46.81	12.27	0.302	1.12	-0.00016	0.5062
1500	300	44.16	18.115	0.213	0.822	-0.00021	0.5061
1500	400	42.45	23.4	0.166	0.646	0.00025	0.5061
2000	100	51.085	5.945	0.488	1.42	1.35E-03	0.6752
2000	200	46.81	12.27	0.265	0.862	0.00065	0.6752
2000	300	44.16	18.115	0.187	0.634	0.00014	0.6749
2000	400	42.45	23.4	0.146	0.498	0.00034	0.675

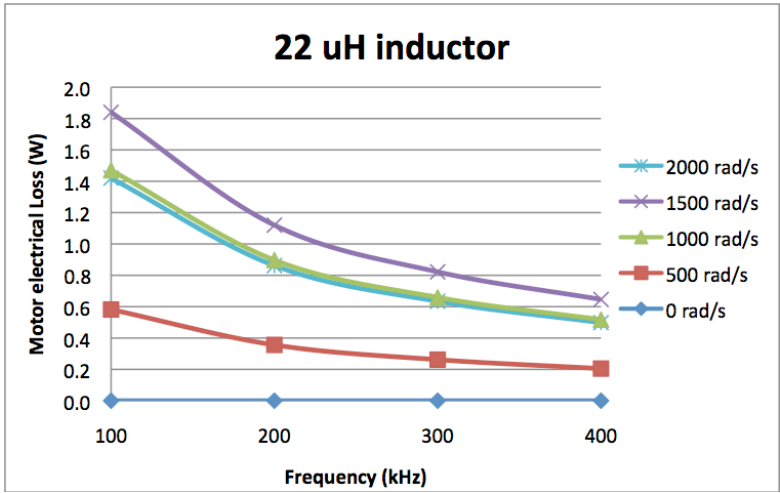

One Inductor

Motor Speed (rad/s)	Frequency (kHz)	Inductance (uH)	Resistance (Ohm)	RMS motor current (A)	Motor electrical loss (W)	Average motor Current (A)	Duty cycle
0	100	76.77	6.61	0.00062	2.57E-06	0.0006	5.00E-05
0	200	72.35	13.51	0.00061	5.08E-06	0.00059	2.00E-04
0	300	69.56	20.05	0.00062	7.74E-06	0.0006	3.00E-04
0	400	67.79	26.05	0.000638	1.06E-05	0.00061	4.00E-04
500	100	76.77	6.61	0.209	2.90E-01	0.0003	1.69E+00
500	200	72.35	13.51	0.111	1.67E-01	0.00133	1.69E-01
500	300	69.56	20.05	0.0768	1.18E-01	-0.00026	1.69E-01
500	400	67.79	26.05	0.0592	9.12E-02	7.68E-05	1.69E-01
1000	100	76.77	6.61	0.333	0.735	0.000605	0.3376
1000	200	72.35	13.51	0.177	0.421	0.00029	0.33745
1000	300	69.56	20.05	0.122	0.3	6.70E-05	0.33745
1000	400	67.79	26.05	0.0942	0.231	0.00015	0.3374
1500	100	76.77	6.61	0.373	0.917	0.00151	0.5065
1500	200	72.35	13.51	0.197	0.526	-0.00014	0.5062
1500	300	69.56	20.05	0.137	0.375	-0.00019	0.5061
1500	400	67.79	26.05	0.105	0.289	0.00023	0.5061
2000	100	76.77	6.61	0.327	0.707	2.95E-16	0.675
2000	200	72.35	13.51	0.173	0.405	0.000592	0.6751
2000	300	69.56	20.05	0.12	0.29	-0.00106	0.6742
2000	400	67.79	26.05	0.0924	0.222	0.0003	0.6749

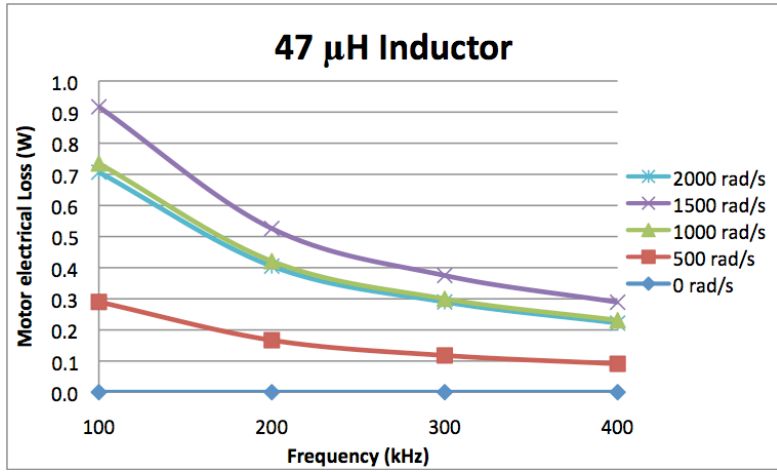

Two Inductors

Motor Speed (rad/s)	Frequency (kHz)	Inductance (μ H)	Resistance (Ohm)	RMS motor current (A)	Motor electrical loss (W)	Average motor Current (A)	Duty cycle
0	100	128.14	7.94	0.00051	2.08E-06	0.0005	1.00E-05
0	200	123.43	15.99	0.0005	4.14E-06	0.0005	1.00E-05
0	300	120.36	23.92	0.0005	6.24E-06	0.0005	1.00E-05
0	400	118.47	31.35	0.00052	8.46E-06	0.00051	1.00E-05
500	100	128.14	7.94	0.126	0.126	0.00126	0.169
500	200	123.43	15.99	0.0653	0.0683	0.000125	0.1687
500	300	120.36	23.92	0.0447	0.0478	0.00027	0.1687
500	400	118.47	31.35	0.034	0.0363	6.38E-05	0.1687
1000	100	128.14	7.94	0.201	0.319	-0.0005	0.3374
1000	200	123.43	15.99	0.104	0.173	0.00025	0.3375
1000	300	120.36	23.92	0.0711	0.121	5.64E-05	0.33745
1000	400	118.47	31.35	0.0542	0.0921	1.20E-04	0.33745
1500	100	128.14	7.94	0.224	0.399	0.00025	0.50625
1500	200	123.43	15.99	0.116	0.216	-0.00012	0.5062
1500	300	120.36	23.92	0.0795	0.151	-0.00016	0.5061
1500	400	118.47	31.35	0.0606	0.115	0.00019	0.5061
2000	100	128.14	7.94	0.197	0.307	4.72E-16	0.675
2000	200	123.43	15.99	0.102	0.167	0.0005	0.6751
2000	300	120.36	23.92	0.0698	0.117	-0.00038	0.6745
2000	400	118.47	31.35	0.0532	0.0886	0.00025	0.6749

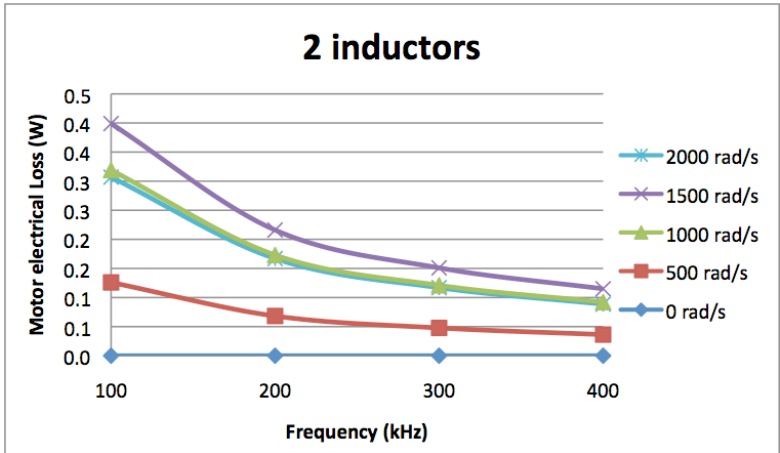

L. Test 11b

- Date: March 30, 2011
- Materials used:
 - LabView simulation programmed by Jason Cortell
 - Data from Test 11
- Controlled variables: Current
- Dependent variables: Power

Current (A)	Power (W) [RI^2]
0.1	0.00042
0.2	0.00168
0.5	0.0105
1	0.042
2	0.168
3	0.378
4	0.672
5	1.05
10	4.2
15	9.45
20	16.8

Speed (rad/s)	Power Savings (W)	
	100 kHz	200 kHz
0	1.48E-06	3.67E-06
500	1.68	1.233
1000	4.205	3.079
1500	5.243	3.824
2000	4.053	2.965

