

Draft v37, Oct 15, 2006

Linearized dynamics equations for the balance and steer of a bicycle: a benchmark and review

BY J. P. MEIJAARD¹, J. M. PAPADOPOULOS², A. RUINA³ AND A. L. SCHWAB⁴

¹*School of MMME, The University of Nottingham, University Park,
Nottingham NG7 2RD, UK*

(Jaap.Meijaard@nottingham.ac.uk)

²*2802 West Carrera Court, Green Bay, WI 54311, USA*

(papadopoulos@alum.mit.edu)

³*Theoretical and Applied Mechanics, and Mechanical and Aerospace Engineering,
Cornell University, Ithaca, NY 14853, USA*

(ruina@cornell.edu)

⁴*Laboratory for Engineering Mechanics, Delft University of Technology,
Mekelweg 2, NL-2628 CD Delft, The Netherlands*

(a.l.schwab@tudelft.nl)

We present canonical linearized equations of motion for the Whipple bicycle model consisting of four rigid laterally-symmetric ideally-hinged parts: two wheels, a frame and a front assembly. The wheels are also axisymmetric and make ideal knife-edge rolling contact with the level ground. The mass distribution and geometry are otherwise arbitrary. This conservative non-holonomic system has a seven-dimensional accessible configuration space and three velocity degrees of freedom parameterized by rates of frame lean, steer angle and rear-wheel rotation. We construct the terms in the governing equations methodically for easy implementation. The equations are suitable for study of, e.g., bicycle self-stability. We derived these equations by hand two ways and also checked them against two non-linear dynamics simulations. In the century-old literature several sets of equations fully agree with those here and several do not. Two benchmarks provide test cases for checking alternative formulations of the equations of motion or alternative numerical solutions. Further, the results here can also serve as a check for general-purpose dynamics programs. For the benchmark bicycles we accurately calculate the stability eigenvalues and the speeds at which bicycle lean and steer are self-stable, confirming the century-old result that this conservative system has asymptotic stability.

Keywords: bicycle, dynamics, linear, stability, nonholonomic, benchmark.

1. Introduction

In 1818 Karl von Drais showed that a person riding forward on a contraption with two in-line wheels, a sitting scooter of sorts, could balance by steering the front wheel (Herlihy 2004). Later, the velocipede of the 1860s which had pedals directly

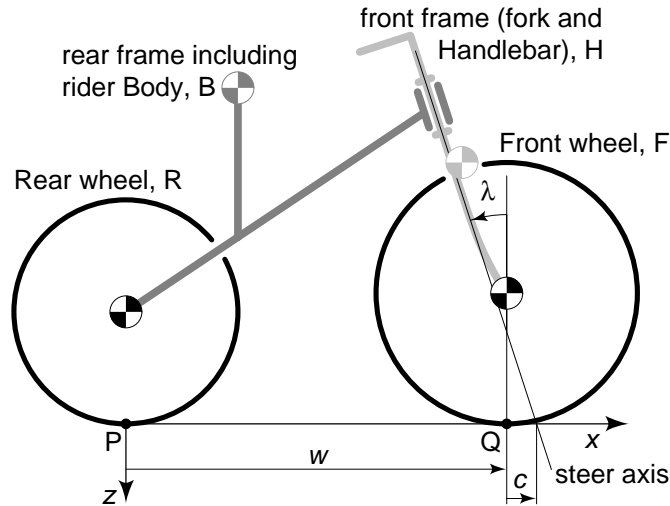

Figure 1. **Bicycle model parameters.** For all four parts (R, B, F and H), centre of mass locations are expressed relative to the x and z coordinates shown (with origin at P and y pointing towards the reader) and in the reference configuration shown. Other parameters include the body masses, the wheel radii, the tilt λ of the steer axis, the wheel base w and the trail c and are listed in table 1. The figure is drawn to scale using the distances in table 1. Configuration variables (lean, steer, etc) are defined in figure 2.

driving the front wheel like a child’s tricycle, could also be balanced by active steering control. This “boneshaker” had equal-size wooden wheels and a vertical (untilted) steering axis passing through the front wheel axle. By the 1890s it was well known that essentially anyone could learn to balance a “safety bicycle”. The safety bicycle had pneumatic tires and a chain drive. More subtly, but more importantly for balance and control, the safety bicycle also had a tilted steer axis and fork offset (bent front fork) like a modern bicycle. In 1897 French mathematician Emmanuel Carvallo (1899) and then, more generally, Cambridge undergraduate Francis Whipple (1899) used rigid-body dynamics equations to show in theory what was surely known in practice, that some safety bicycles could, if moving in the right speed range, balance themselves. Today these same two basic features of bicycle balance are clear:

- A. A controlling rider can balance a forward-moving bicycle by turning the front wheel in the direction of an undesired lean. This moves the ground-contact points back under the rider, just like an inverted broom or stick can be balanced on an open hand by accelerating the support point in the direction of lean.
- B. Some uncontrolled bicycles can balance themselves. If an appropriate typical bicycle is given a push to about 6 m/s, it steadies itself and then progresses stably until its speed gets too low. The torques for the self-correcting steer motions can come from various geometric, inertial and gyroscopic features of the bicycle.

Beyond these two generalities, there is little that has been solidly accepted in the literature, perhaps because of the lack of need. Through trial and error bicycles had

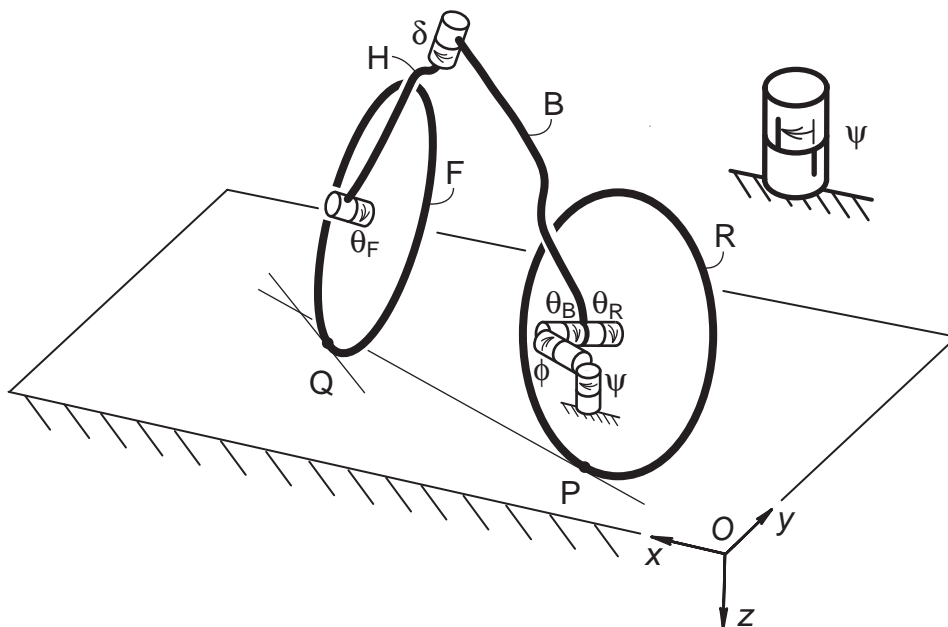

Figure 2. **Configuration and dynamic variables.** The seven-dimensional accessible configuration space is parameterized here by the x and y coordinates of the rear contact P, measured relative to a global fixed coordinate system, and 5 angles represented by a sequence of hinges (gimbals). The hinges are drawn as a pair of cans which rotate with respect to each other. For a positive rotation, the can with arrow rotates in the direction of the arrow relative to its mate as shown on the enlarged isolated can at the top left. The ψ can is grounded in orientation but not in location. For example, a clockwise (looking down) change of heading (yaw) ψ of the rear frame B, is positive. The lean (‘roll’ in aircraft terminology) to the right is ϕ . The rear wheel rotates with θ_R relative to the rear frame, with forward motion being negative. The steer angle is δ with right steer positive. The front wheel rotates with θ_F relative to the front frame. As pictured, ψ , ϕ and δ are all positive. The velocity degrees of freedom are parameterized by $\dot{\phi}$, $\dot{\delta}$ and $\dot{\theta}_R$. The sign convention used is the engineering vehicle dynamics standard (SAE 2001).

evolved by 1890 to be stable enough to survive to the present day with essentially no modification. Because bicycle design has been based on tinkering rather than equations, there has been little scrutiny of bicycle analyses.

To better satisfy general curiosity about bicycle balance and perhaps contribute to the further evolution of bicycle design, we aim here to firmly settle some basic, and largely previously presented, bicycle stability science. The core of the paper is a set of easy-to-use and thoroughly checked linearized dynamics equations for the motion of a somewhat elaborate, yet well-defined, bicycle model. These are in equation (5.3) and Appendix A. Future studies of bicycle stability, aimed for example at clarifying especially point (B) above, can be based on these equations.

Many methods can be used to derive the equations using various choices of coordinates, each leading to vastly different-looking governing equations. Even matching initial conditions between solution methods can be a challenge. However, stability eigenvalues and the speed-range of stability are independent of all of these differences. So, for example, a computer-based study of a bicycle based on any formula-

tion can be checked for correctness and accuracy by comparing with the benchmark eigenvalues here.

The work here may also have more general use. The bicycle balance problem is close to that for skating and perhaps walking and running. Secondly, there is a dearth of non-trivial examples with precisely known solutions that can be used to check general purpose multi-body dynamics simulators (such as are used for machine, vehicle and robot design). This paper provides such a non-trivial benchmark system.

2. Brief literature review

Since their inception bicycles have attracted attention from more-or-less well known scientists of the day including thermodynamicist William Rankine, the mathematicians Carlo Bourlet, Paul Appell and Emmanuel Carvallo, the meteorologist Francis Whipple, the mathematical physicist Joseph Boussinesq, and the physicist Arnold Sommerfeld working with mathematician Felix Klein and engineer Fritz Noether (brother of Emmy). A later peak in the “single-track vehicle” dynamics literature began in about 1970, perhaps because digital computers eased integration of the governing equations, because of the increased popularity of large motorcycles (and attendant accidents), and because of an ecology-related bicycle boom. This latter literature includes work by dynamicists such as Neĭmark, Fufaev, Breakwell and Kane. Starting in the mid-1970s the literature increasingly deviates from the rigid-body treatment that is our present focus. Over the past 140 years scores of other people have studied bicycle dynamics, either for a dissertation, a hobby, or sometimes as part of a life’s work on vehicles. This sparse and varied research on the dynamics of bicycles modelled as linked rigid bodies was reviewed in Hand (1988). Supplementary Appendix 1, summarized below, expands on Hand’s review. A more general but less critical review, which also includes models with compliance, is in Sharp (1985).

Many bicycle analyses aimed at understanding rider control are based on qualitative dynamics discussions that are too reduced to capture the ability of a moving bicycle to balance itself. The *Physics Today* paper by David Jones (1970) is the best-known of these. The paper by Maunsell (1946) carefully considers several effects. Qualitative dynamics discussions can also be found in Lallement (1866), Rankine (1869), Sharp (1896), Appell (1896), Wallace (1929), A.T. Jones (1942), Den Hartog (1948), Higbie (1974), Kirshner (1980), Le Hénaff (1987), Olsen & Papadopoulos (1988), Patterson (1993), Cox (1998), and Wilson (2004).

A second class of papers does use analysis to study the dynamics. Some, appropriately for basic studies of rider control, use models with geometry and/or mass distribution that are too reduced to allow self-stability. Others, even if using a bicycle model that is sufficiently general, use rules for the control of the steer and thus skip the equation for self-steer dynamics. Such simple and/or steer-controlled approaches are found in Bourlet (1899), Boussinesq (1899a,b), Routh (1899), Bouasse (1910), Bower (1915), Pearsall (1922), Loĭcjanskiĭ & Lur’e (1934), Timoshenko & Young (1948), Haag (1955), Neĭmark & Fufaev (1967), Lowell & McKell (1982), Getz & Marsden (1995), Fajans (2000), Åström *et al.* (2005) and Limebeer & Sharp (2006).

Finally, we have found about 30 rigid-body dynamics models that have general-enough geometry and mass distribution for self-stability to be possible, and which also allow uncontrolled steer dynamics. These governing equations are complex and different authors use slightly different modelling assumptions, different parameterizations and different choices of dynamic variables. And most authors did not know of most of their predecessors. So only a small fraction of the 200 or more chronologically possible cross checks have been performed in detail. Of these a large fraction are by Hand and ourselves. The evaluations below are based on comparison with our own derivations (Papadopoulos, 1987 and Meijaard 2004), and by comparisons made by the first 6 authors below, especially Hand.

Correct equations for the Whipple model are in Döhring (1955) who built on the less-general Carvallo model presented in Klein & Sommerfeld (1910), Weir (1972) who checked Sharp, Eaton (1973) who checked Weir and Sharp, Hand (1988) who checked these papers and others, Mears (1988) who checked Weir and Hand, and Lennartsson (1999). Singh & Goel (1971) use Döhring's correct equations, but we did not check their implementation. The paper by Dikarev *et al.* (1981) corrects the same error as found independently by Hand in Neimark & Fufaev (1967) and we have found no fault with it, but we have not confirmed the final equations. Based on graphical agreement of Psiaki's (1979) plots with solutions of the equations here we expect that Psiaki's complex equations are correct, but we have not confirmed their equivalence to the equations here. We recently discovered a report by Manning (1951) that has no evident flaws, but we have not checked it in detail. Equations of similar models are in Carvallo (1899) which is slightly simplified, Whipple (1899) which has some typographical errors, Klein & Sommerfeld (1910) which follows Carvallo and is slightly simplified, Herfkens (1949) which has some typographical errors, Sharp (1971) which is correct before he eliminates tire compliance and is the foundation for much subsequent tire-based vehicle modelling, Van Zytveld (1975) which is correct when his slightly incorrect and more general model is simplified to the Whipple model, and Weir & Zellner (1978) which has minor errors. Neimark & Fufaev (1967) has more substantial but still correctable errors (see Dikarev *et al.* (1981) and Hand (1988)).

Others who studied complex rigid-body bicycle models include Collins (1963), Singh (1964), Rice & Roland (1970), Roland & Massing (1971), Roland & Lynch (1972), Roland (1973), Rice (1974), Singh & Goel (1975), Rice (1976), Lobas (1978), Koenen (1983), and Franke *et al.* (1990). We continue to discover more promising papers (e.g., Kondo *et al.* (1963) and Ge (1966)). Despite all these decades of careful good work, there is no peer-reviewed paper in English that, as of this writing, we are confident has fully correct equations for the Whipple model.

3. The Bicycle Model

We use the Whipple bicycle consisting of four rigid bodies: a Rear wheel R, a rear frame B with the rider Body rigidly attached to it, a front frame H consisting of the Handlebar and fork assembly, and a Front wheel F (figure 1). Within the constraint of overall lateral (left-right) symmetry and circular symmetry of the wheels, the shape and mass distributions are fully general. A model that respects these symmetries allows non-planar (thick) wheels. We allow for such thickness in our inertial properties but, like Whipple, add the assumption of knife-edge rolling

contact, precluding, e.g., contact with toroidal wheels. We neglect the motion of the rider relative to the frame, structural compliances and dampers, joint friction, tire compliance and tire “slip”.

The model delineation is not by selecting the most important aspects for describing real bicycle stability. For understanding basic features of active rider control the model here is undoubtedly unnecessarily and inappropriately complex. For example, some aspects included here have very small effects, like the non-planarity of the inertia of the real wheel. And other neglected aspects may be paramount, e.g. the rider’s flexibility and control reflexes. Even for the study of uncontrolled stability, tire deformation and frame compliance seem necessary for understanding wobble (shimmy). In summary, the model here includes all the sharply-defined rigid-body effects, while leaving out a plethora of terms that would require more subtle and less well-defined modelling.

Our bicycle design is fully characterized by 25 parameters described below. Table 1 lists the numerical values used for the numerical benchmark. The numerical values are mostly fairly realistic, but some values (e.g., wheel inertial thickness as represented by $I_{Rxx} > I_{Ryy}/2$) are exaggerated to guarantee a significant role in the benchmark numerical studies. The bicycle design parameters are defined in an upright reference configuration with both wheels on the level flat ground and with zero steer angle. The reference coordinate origin is at the rear wheel contact point P. We use the slightly odd conventions of vehicle dynamics (SAE 2001) with positive x pointing towards the front contact point, positive z pointing down and the y axis pointing to the rider’s right.

The radii of the circular wheels are r_R and r_F . The wheel masses are m_R and m_F with their centres of mass at the wheel centres. The moments of inertia of the rear and front wheels about their axles are I_{Ryy} and I_{Fyy} . The moments of inertia of the wheels about any diameter in the xz plane are I_{Rxx} and I_{Fxx} . The wheel mass distribution need not be planar, so any positive inertias are allowed with $I_{Ryy} \leq 2I_{Rxx}$ and $I_{Fyy} \leq 2I_{Fxx}$. All front wheel parameters can be different from those of the rear so, for example, it is possible to investigate separately the importance of angular momentum of the front and rear wheels.

Narrow high-pressure high-friction tire contact is modelled as non-slipping rolling contact between the ground and the knife-edge wheel perimeters. The frictionless wheel axles are orthogonal to the wheel symmetry planes and are located at the wheel centres. In the reference configuration the front wheel ground contact Q is located at a distance w (the “wheel base”) in front of the rear wheel contact P. The front wheel ground contact point trails a distance c behind the point where the steer axis intersects with the ground. Although $c > 0$ for most bicycles, the equations allow a ‘negative trail’ ($c < 0$) with the wheel contact point in front of the steer axis.

The rear wheel R is connected to the rear frame assembly B (which includes the rider body) at the rear axle. The centre of mass of B, with mass m_B , is located at $(x_B, y_B = 0, z_B < 0)$. The moment of inertia of the rear frame about its centre of mass is represented by a 3×3 moment of inertia matrix where all mass is symmetrically distributed relative to the xz plane, but not necessarily on the plane. The centre of mass of the front frame assembly (fork and handlebar) H is at $(x_H, y_H = 0, z_H < 0)$ relative to the rear contact P. H has mass m_H . As for the B frame, I_{Hyy} can be less than $I_{Hxx} + I_{Hzz}$. The rear and front moments of inertia of

the rear and front assemblies are:

$$\mathbf{I}_B = \begin{bmatrix} I_{Bxx} & 0 & I_{Bxz} \\ 0 & I_{Byy} & 0 \\ I_{Bxz} & 0 & I_{Bzz} \end{bmatrix}, \quad \text{and} \quad \mathbf{I}_H = \begin{bmatrix} I_{Hxx} & 0 & I_{Hxz} \\ 0 & I_{Hyy} & 0 \\ I_{Hxz} & 0 & I_{Hzz} \end{bmatrix}. \quad (3.1)$$

The steer axis tilt angle λ is measured back from the upwards vertical, positive when tipped back as on a conventional bicycle with $-\pi/2 < \lambda < \pi/2$ (all angles in radians). The steer tilt is $\pi/2$ minus the conventional ‘‘head angle’’; a bicycle with head angle of 72° has $\lambda = 18^\circ = \pi/10$. The steer axis location is implicitly defined by the wheel base w , trail c and steer axis tilt angle λ .

Two non-design parameters are the downwards gravitational acceleration g and the nominal forward speed v . This model, or slight simplifications of it, is a common idealization of a bicycle (see Supplementary Appendix 1). Motorcycle modelling is often based on an extension of this model using toroidal wheels, tire compliance, tire slip and frame compliance. Theories of bicycle and motorcycle control are often based on simplifications of this model or, alternatively, on simple analogous systems that do not come from reductions of this model.

(a) *How many parameters describe a bicycle?*

The bicycle model here is defined completely by the 25 design parameters above (see table 1). This is not a minimal description for dynamic analysis, however. For example, the inertial properties of the rear wheel R, except for the polar moment of inertia (i.e., m_R and I_{Rxx} but not I_{Ryy}), can be combined with the inertial properties of the rear frame B, reducing the number of parameters by 2. Similarly for the front frame, reducing the number of parameters to $25 - 2 - 2 = 21$. The polar inertia of each wheel can be replaced with a gyrostat constant each of which gives a spin angular momentum in terms of forward velocity. This does not reduce the number of parameters in non-linear modelling. But in linear modelling the radius of the wheels is irrelevant for lean and steer geometry and their effect on angular momentum is embodied in the gyrostat constants. Thus eliminating wheel radii reduces the number of parameters by 2 to $21 - 2 = 19$. Finally, in the linearized equations of motion the polar (yy components) of the moments of inertia of the two frames are irrelevant, reducing the necessary number of design parameters to $19 - 2 = 17$. In their most reduced form the linearized equations of motion (5.3) have 11 arbitrary independent matrix entries. Each entry is a complex combination of the 17 parameters just described. Further reduction can be obtained by inspection of the fourth order characteristic equation (6.5). After scaling by the leading coefficient $\det(\mathbf{M})$, there remain four polynomial coefficients. Each coefficient of the characteristic polynomial is a polynomial in the forward speed. There are seven independent coefficients of these velocity polynomials. By reduction using suitable length and time scales, two of these coefficients can be eliminated. So the space of scaled root loci plots is only five-dimensional. For simpler comparisons, we use all 25 design parameters.

(b) *How many degrees of freedom does a bicycle have?*

Because this system has non-holonomic kinematic constraints, the concept of ‘‘degree of freedom’’ needs clarification. The holonomic (hinges and ground contact)

and non-holonomic (non-slip rolling) constraints restrict these four linked three-dimensional objects in space as follows. Start with the 24 degrees of freedom of the 4 rigid bodies, each with 3 translational and 3 rotational degrees of freedom in physical space ($4 \times (3 + 3) = 24$). Then subtract out 5 degrees of freedom for each of the three hinges and one more for each wheel touching the ground plane: $24 - 3 \times 5 - 2 = 7$. Thus, before we consider the non-slipping wheel-contact constraints, the accessible configuration space is seven-dimensional. The 4 non-holonomic rolling constraints (two for each wheel-to-ground contact) do not further restrict this accessible configuration space: kinematically allowable rolling motions can translate and steer the bicycle on the plane in arbitrary ways and also can rotate the wheels relative to the frame with no net change of overall bicycle position or orientation. For example, even though side-slip is not allowed, a bicycle can move sideways by the same motions used to parallel-park a car. Thus the accessible configuration space for this model is 7-dimensional.

(i) *Description of the seven-dimensional configuration space*

This seven-dimensional configuration space can be parameterized as follows (see figure 2). The location of the rear-wheel contact with the ground is (x_P, y_P) relative to a global fixed coordinate system with origin O. The orientation of the rear frame with respect to the global reference frame O- xyz is given by a sequence of angular rotations (Euler angles). These rotations are depicted in figure 2 with fictitious hinges, each represented as a can in the drawing, in series, mounted at the rear hub: a yaw rotation, ψ , about the z -axis, a lean rotation, ϕ , about the rotated x -axis, and a pitch rotation, θ_B , about the rotated y -axis. Note that the pitch θ_B is not one of the 7 configuration variables because it is determined by a 3-D trigonometric relation that keeps the front wheel on the ground. The steering angle δ is the rotation of the front handlebar frame with respect to the rear frame about the steering axis. A right turn of a forwards-moving bicycle has $\delta > 0$. Finally, the rotation of the rear R and front F wheels with respect to their respective frames B and H are θ_R and θ_F . In summary, the configuration space is parameterized here with $(x_P, y_P, \psi, \phi, \delta, \theta_R, \theta_F)$. Quantities such as wheel-centre coordinates and rear-frame pitch are all determined by these.

(ii) *Velocity degrees of freedom*

As explained above, the accessible configuration space is seven-dimensional. However, the 4 non-holonomic rolling constraints reduce the seven-dimensional accessible configuration space to $7 - 4 = 3$ velocity degrees of freedom. This 3-dimensional kinematically accessible velocity space can conveniently be parameterized by the lean rate $\dot{\phi}$ of the rear frame, the steering rate $\dot{\delta}$ and the rotation rate $\dot{\theta}_R$ of the rear wheel R relative to the rear frame B.

4. Basic features of the model, equations and solutions

(a) *The system behaviour is unambiguous*

The dynamics equations for this model follow from linear and angular momentum balance applied to each part, along with the assumption that the kine-

<u>Parameter</u>	<u>Symbol</u>	<u>Value for benchmark</u>
Wheel base	w	1.02 m
Trail	c	0.08 m
Steer axis tilt ($\pi/2 - \text{head angle}$)	λ	$\pi/10$ rad ($90^\circ - 72^\circ$)
Gravity	g	9.81 N/kg
Forward speed	v	<i>various</i> m/s, see tables b–2
<u>Rear wheel R</u>		
Radius	r_R	0.3 m
Mass	m_R	2 kg
Mass moments of inertia	(I_{Rxx}, I_{Ryy})	(0.0603, 0.12) kgm ²
<u>Rear Body and frame assembly B</u>		
Position centre of mass	(x_B, z_B)	(0.3, –0.9) m
Mass	m_B	85 kg
Mass moments of inertia	$\begin{bmatrix} I_{Bxx} & 0 & I_{Bxz} \\ 0 & I_{Byy} & 0 \\ I_{Bxz} & 0 & I_{Bzz} \end{bmatrix}$	$\begin{bmatrix} 9.2 & 0 & 2.4 \\ 0 & 11 & 0 \\ 2.4 & 0 & 2.8 \end{bmatrix}$ kgm ²
<u>Front Handlebar and fork assembly H</u>		
Position centre of mass	(x_H, z_H)	(0.9, –0.7) m
Mass	m_H	4 kg
Mass moments of inertia	$\begin{bmatrix} I_{Hxx} & 0 & I_{Hxz} \\ 0 & I_{Hyy} & 0 \\ I_{Hxz} & 0 & I_{Hzz} \end{bmatrix}$	$\begin{bmatrix} 0.05892 & 0 & -0.00756 \\ 0 & 0.06 & 0 \\ -0.00756 & 0 & 0.00708 \end{bmatrix}$ kgm ²
<u>Front wheel F</u>		
Radius	r_F	0.35 m
Mass	m_F	3 kg
Mass moments of inertia	(I_{Fxx}, I_{Fyy})	(0.1405, 0.28) kgm ²

Table 1. *Parameters for the benchmark bicycle depicted in figure 1 and described in the text. The values given are exact (no round-off). The inertia components and angles are such that the principal inertias (eigenvalues of the inertia matrix) are also exactly described with only a few digits. The tangents of the angles that the inertia eigenvectors make with the global reference axes are rational fractions. To be physical (no negative mass) moment-of-inertia matrix entries must all be positive and also satisfy the triangle inequalities that no one principal value is bigger than the sum of the other two.*

matic constraint forces follow the rules of action and reaction and do no net work. These equations may be assembled into a set of ordinary differential equations, or differential-algebraic equations by various methods. One can assemble governing differential equations using the Newton–Euler rigid-body equations, using Lagrange equations with Lagrange multipliers for the in-ground-plane rolling-contact forces, or one can use methods based on the principle of virtual velocities (e.g., Kane’s method), etc. But the subject of mechanics is sufficiently well defined that we know that all standard methods will yield equivalent sets of governing differential equations. Therefore, a given consistent-with-the-constraints initial state (positions and velocities of all points on the frames and wheels) will always yield the same subsequent motions of the bicycle parts. So, while the choice of variables and the recombination of governing equations may lead to quite different looking governing equations, any difference between dynamics predictions can only be due to errors.

(b) The system is conservative but not Hamiltonian

The only friction forces in this model are the lateral and longitudinal forces at the ground-contact points. Because of the no-slip condition these friction forces are non-dissipative. The hinges and ground contact are all workless kinematic constraints. In uncontrolled bicycle motion the only external applied forces are the conservative gravity forces on each part. That is, there are no dissipative forces and the system is energetically conservative; the sum of the gravitational and kinetic energies is a constant for any free motion. But the non-holonomic kinematic constraints preclude writing the governing equations in standard Hamiltonian form, so theorems of Hamiltonian mechanics do not apply. One result, surprising to some cultured in Hamiltonian systems, is that the bicycle equations can have asymptotic (exponential) stability (see figure 4) even with no dissipation. This apparent contradiction of the stability theorems for Hamiltonian systems is because the bicycle, while conservative, is, by virtue of the non-holonomic wheel contacts, not Hamiltonian. A similar system that is conservative but has asymptotic stability is the uncontrolled skateboard (Hubbard 1979) and more simple still is the classical Chaplygin sleigh described in, e.g., Ruina (1998).

(c) Symmetries in the solutions

Without explicit use of the governing equations some features of their solutions may be inferred by symmetry.

Ignorable coordinates. Some of the configuration variables do not appear in any expression for the forces, moments, potential energies or kinetic energies of any of the parts (these are so-called cyclic or ignorable coordinates). In particular the location of the bicycle on the plane (x_P, y_P) , the heading of the bicycle ψ , and the rotations (θ_R, θ_F) of the two wheels relative to their respective frames do not show up in any of the dynamics equations for the velocity degrees of freedom. So one can write a reduced set of dynamics equations that do not include these ignorable coordinates. The full configuration as a function of time can be found afterwards by integration of the kinematic constraint equations, as discussed at the end of Appendix B. These ignorable coordinates cannot have asymptotic stability; a small perturbation of, say, the heading ψ will lead to a different ultimate heading.

Decoupling of lateral dynamics from speed dynamics. The lateral (left-right) symmetry of the bicycle-design along with the lateral symmetry of the equations implies that the straight-ahead unsteered and untipped ($\delta = 0, \phi = 0$) rolling motions are necessarily solutions for any forward or backward speed v . Moreover, relative to these symmetric solutions, the longitudinal and the lateral motion must be decoupled from each other to first order (linearly decoupled) by the following argument. Because of lateral symmetry a perturbation to the right must cause the same change in speed as a perturbation to the left. But by linearity the effects must be the negative of each other. Therefore there can be no first-order change in speed due to lean. Similarly, speed change cannot cause lean. So the linearized fore-aft equations of motion are entirely decoupled from the lateral equations of motion and a constant speed bicycle has the same equations of motion as a constant energy bicycle. This argument is given in more detail in Supplementary Appendix 4.

A fore-aft symmetric bicycle cannot be asymptotically self stable. Because all of the equations of such frictionless kinematically constrained systems are time

reversible, any bicycle motion is also a solution of the equations when moving backwards, with all particle trajectories being traced at identical speeds in the reverse direction. Thus a bicycle that is exponentially stable in balance when moving forwards at speed $v > 0$ must be exponentially unstable when moving at $-v$ (backwards at the same speed). Consider a fore-aft symmetric bicycle. Such a bicycle would have a vertical central steering axis and has a handlebar assembly, front mass distribution and front wheel that mirrors that of the rear assembly. If such a bicycle has exponentially decaying solutions in one direction it must have exponentially growing solutions in the opposite direction because of time reversal. By symmetry it must therefore also have exponentially growing solutions in the (supposedly stable) original direction. Thus such a bicycle cannot have exponentially decaying solutions in one direction without also having exponentially growing solutions in the same direction, and thus can't be asymptotically self-stable. Such a symmetric bicycle might, however, have the oscillatory (neutral) stability (the kind of stability that Hamiltonian systems can have).

(d) *The non-linear equations have no simple expression*

In contrast with the linear equations we present below, there seems to be no reasonably compact expression of the full non-linear equations of motion for this model. The kinematic loop, from rear-wheel contact to front-wheel contact, determines the rear frame pitch through a quartic equation (Psiaki 1979), so there is no simple expression for rear frame pitch for large lean and the steer angle. Thus the writing of non-linear governing differential equations in a standard form that various researchers can check against alternative derivations is a challenge that is not addressed here, and might never be addressed. However, when viewed as a collection of equations, one for each part, and a collection of constraint equations, a large set of separately comprehensible equations may be assembled. An algorithmic derivation of non-linear equations using such an assembly, suitable for numerical calculation and benchmark comparison, is presented in (Basu-Mandal *et al.* 2006) where various no-hands circular motions are also presented.

5. Linearized equations of motion

Here we present a set of linearized differential equations for the bicycle model, slightly perturbed from upright straight-ahead motion, in a canonical form. To aid in organizing the equations we include applied roll and steer torques which are later set to zero for study of uncontrolled motion.

(a) *Derivation of governing equations*

Mostly-correct derivations and presentations of the equations of motion for a relatively general bicycle model, although not necessarily expressed in the canonical form of equation (5.3), are found in Carvallo (1899), Whipple (1899), Klein & Sommerfeld (1910), Döhning (1953, 1955), Sharp (1971), Weir (1972), Eaton (1973) and Van Zytveld (1975). Dikarev *et al.* (1981) have a derivation of equation (5.3) based on correcting the errors in Neimark and Fufaev (1967) as does Hand (1988) which just predates Mears (1988). Papadopoulos (1987) and Meijaard (2004) also

have derivations which were generated in preparation for this paper. The derivations above are generally long, leading to equations with layers of nested definitions. This is at least part of the reason for the lack of cross checking in the literature. A minimal derivation of the equations using angular momentum balance about various axes, based on Papadopoulos (1987), is given in Appendix B. Note that this derivation, as well as all of the linearized equations from the literature, are not based on a systematic linearization of full non-linear differential equations. Thus far, systematic linearizations have not achieved analytical expressions for the linearized-equation coefficients in terms of the 25 bicycle parameters. However, part of the validation process described later includes comparison with full non-linear simulations, and also comparison with numerical values of the linearized-equation coefficients as determined semi-analytically by these same non-linear programs.

(b) *Forcing terms*

For numerical benchmark purposes, where eigenvalues are paramount, we neglect control forces or other forcing (except gravity which is always included). However, the forcing terms help to organize the equations. Moreover, forcing terms are needed for study of disturbances and control.

In addition to the gravity forces, consider an arbitrary distribution of forces \mathbf{F}_i acting at various points on the bicycle. Their net effect is to contribute to the forces of constraint (the ground reaction forces, and the action-reaction pairs between the parts at the hinges) and to contribute to the accelerations $(\ddot{\phi}, \ddot{\delta}, \ddot{\theta}_R)$. Three generalized forces can be defined by writing the power of the applied forces, kept at their current values, associated with arbitrary perturbations of the velocities that are consistent with the hinge-assembly and ground-wheel contact constraints. This “virtual” power necessarily factors into a sum of three terms

$$P = \sum \mathbf{F}_i \cdot \Delta \mathbf{v}_i = T_\phi \Delta \dot{\phi} + T_\delta \Delta \dot{\delta} + T_{\theta_R} \Delta \dot{\theta}_R, \quad (5.1)$$

because the perturbations of the velocities $\Delta \mathbf{v}_i$ of all material points are necessarily linear combinations of the perturbations of the generalized velocities $(\Delta \dot{\phi}, \Delta \dot{\delta}, \Delta \dot{\theta}_R)$. The generalized forces $(T_\phi, T_\delta, T_{\theta_R})$ are thus each linear combinations of the components of the various applied forces \mathbf{F}_i .

The generalized forces $(T_\phi, T_\delta, T_{\theta_R})$ are energetically conjugate to the generalized velocities. The generalized forces can be visualized by considering special loadings each of which contributes to only one generalized force when the bicycle is in the reference configuration. In this way of thinking

1. T_{θ_R} is the propulsive “force”, expressed as an equivalent moment on the rear wheel. In practice pedal torques or a forward push on the bicycle contribute to T_{θ_R} and not to T_ϕ and T_δ .
2. T_ϕ is the right lean torque, summed over all the forces on the bicycle, about the line between the wheel ground contacts. A sideways force on the rear frame located directly above the rear contact point contributes only to T_ϕ . A sideways wind gust, or a parent holding a beginning rider upright contributes mainly to T_ϕ .

3. T_δ is an action-reaction steering torque. A torque causing a clockwise (looking down) action to the handlebar assembly H along the steer axis and an equal and opposite reaction torque on the rear frame contributes only to T_δ . In simple modelling, T_δ would be the torque that a rider applies to the handlebars. Precise description of how general lateral forces contribute to T_δ depends on the projection implicit in equation (5.1). Some lateral forces make no contribution to T_δ , namely those acting at points on either frame which do not move when an at-rest bicycle is steered but not leaned. Lateral forces applied to the rear frame directly above the rear contact point make no contribution to T_δ . Nor do forces applied to the front frame if applied on the line connecting the front contact point with the point where the steer axis intersects the vertical line through the rear contact point. Lateral forces at ground level, but off the two lines just described, contribute only to T_δ . Lateral forces acting at the wheel contact points make no contribution to any of the generalized forces.

Just as for a pendulum, finite vertical forces (additional to gravity) change the coefficients in the linearized equations of motion but do not contribute to the forcing terms. Similarly, propulsive forces also change the coefficients but have no first order effect on the lateral forcing. Thus the equations presented here only apply for small ($\ll \sum mg$) propulsive and small additional vertical forces.

(c) *The first linear equation: with no forcing, forward speed is constant*

A solution of both the linearized and the full non-linear equations is straight-ahead $\delta = 0$ upright $\phi = 0$ motion at any constant forward speed $v = -\dot{\theta}_R r_R$. The governing equations here describe the evolution of small perturbations from this reference solution. As explained above and in more detail in Supplementary Appendix 4, lateral symmetry of the system, combined with the linearity in the equations precludes any first-order coupling between the forward motion and the lean and steer. Therefore the first linearized equation of motion is simply obtained from two-dimensional (xz -plane) mechanics as:

$$\left[r_R^2 m_T + I_{Ryy} + (r_R/r_F)^2 I_{Fyy} \right] \ddot{\theta}_R = T_{\theta_R}, \quad (5.2)$$

where m_T is total bicycle mass (see Appendix A). That is, in cases with no propulsive force the nominal forward speed $v = -r_R \dot{\theta}_R$ is constant (to first order).

(d) *Lean and steer equations*

The linearized equations of motion for the two remaining degrees of freedom, the lean angle ϕ and the steer angle δ , are two coupled second-order constant-coefficient ordinary differential equations. Any such set of equations can be linearly combined to get an equivalent set. We define the canonical form below by insisting that the right-hand sides of the two equations consist only of T_ϕ and T_δ , respectively. The first of these two equations is the *lean equation* and the second is the *steer equation*. That we have a mechanical system requires that the linear equations have the form $\mathbf{M}\ddot{\mathbf{q}} + \mathbf{C}\dot{\mathbf{q}} + \mathbf{K}\mathbf{q} = \mathbf{f}$. For the bicycle these equations can be written as (Papadopoulos 1987)

$$\mathbf{M}\ddot{\mathbf{q}} + v\mathbf{C}_1\dot{\mathbf{q}} + [g\mathbf{K}_0 + v^2\mathbf{K}_2]\mathbf{q} = \mathbf{f}, \quad (5.3)$$

where the time-varying variables are $\mathbf{q} = \begin{bmatrix} \phi \\ \delta \end{bmatrix}$ and $\mathbf{f} = \begin{bmatrix} T_\phi \\ T_\delta \end{bmatrix}$. The constant entries in matrices \mathbf{M} , \mathbf{C}_1 , \mathbf{K}_0 and \mathbf{K}_2 are defined in terms of the 25 design parameters in Appendix A. Briefly, \mathbf{M} is a symmetric mass matrix which gives the kinetic energy of the bicycle system at zero forward speed by $\dot{\mathbf{q}}^T \mathbf{M} \dot{\mathbf{q}}/2$. The damping-like (there is no real damping) matrix $\mathbf{C} = v\mathbf{C}_1$ is linear in the forward speed v and captures gyroscopic torques due to steer and lean rate, inertial reaction from the rear frame yaw rate (due to trail), and inertial reaction from yaw acceleration proportional to steer rate. The stiffness matrix \mathbf{K} is the sum of two parts: a velocity-independent symmetric part $g\mathbf{K}_0$ proportional to the gravitational acceleration, which can be used to calculate changes in potential energy with $\mathbf{q}^T [g\mathbf{K}_0] \mathbf{q}/2$, and a part $v^2\mathbf{K}_2$ which is quadratic in the forward speed and is due to gyroscopic and centrifugal effects. The matrix subscripts match the exponents of the v multipliers.

Equation (5.3) above is the core of this paper.

6. Benchmark model and solutions

To facilitate comparisons by those using other derivations, especially those using less explicit numerical approaches, we have defined a benchmark bicycle with all parameter values given in table 1. The parameter values were chosen to minimize the possibility of fortuitous cancellation that could occur if used in an incorrect model. On the other hand we wanted numbers that could be easily described precisely. In the benchmark bicycle the two wheels are different in all properties and no two angles, masses or distances match. A second simpler benchmark is in Supplementary Appendix 5.

(a) Coefficients of the linearized equations of motion

Substitution of the values of the design parameters for the benchmark bicycle from table 1 in the expressions from Appendix A results in the following values for the entries in the matrices in the equations of motion (5.3):

$$\mathbf{M} = \begin{bmatrix} 80.817\ 22 & 2.319\ 413\ 322\ 087\ 09 \\ 2.319\ 413\ 322\ 087\ 09 & 0.297\ 841\ 881\ 996\ 86 \end{bmatrix}, \quad (6.1)$$

$$\mathbf{K}_0 = \begin{bmatrix} -80.95 & -2.599\ 516\ 852\ 498\ 72 \\ -2.599\ 516\ 852\ 498\ 72 & -0.803\ 294\ 884\ 586\ 18 \end{bmatrix}, \quad (6.2)$$

$$\mathbf{K}_2 = \begin{bmatrix} 0 & 76.597\ 345\ 895\ 732\ 22 \\ 0 & 2.654\ 315\ 237\ 946\ 04 \end{bmatrix}, \text{ and} \quad (6.3)$$

$$\mathbf{C}_1 = \begin{bmatrix} 0 & 33.866\ 413\ 914\ 924\ 94 \\ -0.850\ 356\ 414\ 569\ 78 & 1.685\ 403\ 973\ 975\ 60 \end{bmatrix}. \quad (6.4)$$

The coefficients are given with 14 decimal places (trailing zeros suppressed) above and elsewhere in this paper as a benchmark. Many-digit agreement between results obtained by other means and this benchmark provides near certainty that there is also an underlying mathematical agreement, even if that agreement is not apparent analytically.

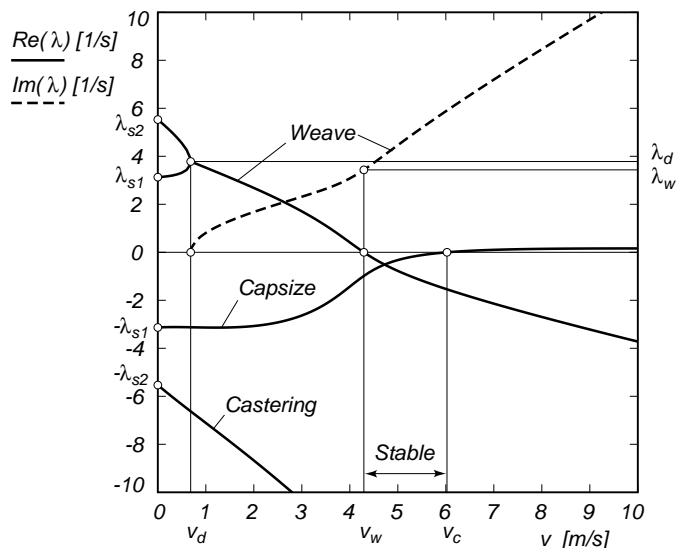

Figure 3. Eigenvalues λ from the linearized stability analysis for the benchmark bicycle from figure 1 and table 1 where the solid lines correspond to the real part of the eigenvalues and the dashed line corresponds to the imaginary part of the eigenvalues, in the forward speed range of $0 \leq v \leq 10$ m/s. The speed range for the asymptotic stability of the benchmark bicycle is $v_w < v < v_c$. The zero crossings of the real part of the eigenvalues are for the weave motion at the weave speed $v_w \approx 4.292$ m/s and for the capsize motion at capsize speed $v_c \approx 6.024$ m/s, and there is a double real root at $v_d \approx 0.684$ m/s. For accurate eigenvalues and transition speeds see table 2.

(b) *Linearized stability, eigenvalues for comparison*

Stability eigenvalues are independent of coordinate choice and even independent of the form of the equations. Any non-singular change of variables yields equations with the same linearized stability eigenvalues. Thus stability eigenvalues serve well as convenient benchmark results permitting comparison between different approaches. The stability eigenvalues are calculated by assuming an exponential solution of the form $\mathbf{q} = \mathbf{q}_0 \exp(\lambda t)$ for the homogeneous equations ($\mathbf{f} = \mathbf{0}$ in equations 5.3). This leads to the characteristic polynomial,

$$\det(\mathbf{M}\lambda^2 + v\mathbf{C}_1\lambda + g\mathbf{K}_0 + v^2\mathbf{K}_2) = 0, \quad (6.5)$$

which is quartic in λ . After substitution of the expressions from Appendix A, the coefficients in this quartic polynomial become complicated expressions of the 25 design parameters, gravity and speed v . The solutions λ of the characteristic polynomial for a range of forward speeds are shown in figure 3. Eigenvalues with a positive real part correspond to unstable motions whereas eigenvalues with a negative real part correspond to asymptotically stable motions for the corresponding mode. Imaginary eigenvalues correspond to oscillatory motions. As mentioned earlier, the time-reversal nature of these conservative dynamical equations leads to symmetry in the characteristic equation (6.5) and in the parameterized solutions: if (v, λ) is a solution then $(-v, -\lambda)$ is also a solution. This means that figure 3 is point symmetric about the origin as revealed in figure 9 of Åström *et al.* (2005).

This fourth order system has four distinct eigenmodes except at special parameter values associated with multiple roots. A complex (oscillatory) eigenvalue pair is associated with a pair of complex eigenmodes. At high enough speeds, the two modes most significant for stability are traditionally called the *capsize mode* and *weave mode*. The capsize mode corresponds to a real eigenvalue with eigenvector dominated by lean: when unstable, a capsizing bicycle leans progressively into a tightening spiral with steer and lean both increasing as it falls over. The weave mode is an oscillatory motion in which the bicycle steers sinusously about the headed direction with a slight phase lag relative to leaning. The third eigenvalue is large, real and negative. It corresponds to the *castering mode* which is dominated by steer in which the front ground contact follows a tractrix-like pursuit trajectory, like the straightening of a swivel wheel under the front of a grocery cart.

At near-zero speeds, typically $0 < v < 0.5$ m/s, there are two pairs of real eigenvalues. Each pair consists of a positive and a negative eigenvalue and corresponds to an inverted-pendulum-like falling of the bicycle. The positive root in each pair corresponds to falling, whereas the negative root corresponds to the time reversal of this falling. When speed is increased to $v_d \approx 0.684$ m/s two real eigenvalues become identical and form a complex conjugate pair; this is where the oscillatory weave motion emerges. At first this motion is unstable but at $v_w \approx 4.292$ m/s, the *weave speed*, these eigenvalues cross the imaginary axis in a Hopf bifurcation and this mode becomes stable. At a higher speed the capsize eigenvalue crosses the origin in a pitchfork bifurcation at $v_c \approx 6.024$ m/s, the *capsize speed*, and the bicycle becomes mildly unstable. The speed range for which the uncontrolled bicycle shows asymptotically stable behaviour, with all eigenvalues having negative real part, is $v_w < v < v_c$. For comparison by future researchers, benchmark eigenvalues are presented at various forward speeds in table 2.

7. Validation of the linearized equations of motion

The linearized equations of motion here, equation (5.3) with the coefficients as presented in Appendix A, have been derived by pencil and paper in two ways (Papadopoulos 1987, Meijaard 2004), and agree exactly with some of the past literature, see §2. We have also checked equation coefficients via the linearization capability of two general non-linear dynamics simulation programs described below. Comparisons with the work here using non-linear simulations have also been performed by Lennartsson (2006 — personal communication, based on Lennartsson 1999) and Basu-Mandal *et al.* (2006). Finally, in the self-stable speed range steering and lean transients can be measured on a physical bicycle with narrow high-pressure tires. Kooijman (2006) measured the mass and geometry parameters on one bicycle and found good comparison between the experimentally measured eigenvalues and the eigenvalues predicted by the formulas here.

(a) Equations of motion derived with the numeric program SPACAR

SPACAR is a program system for dynamic simulation of multibody systems developed by Van der Werff (1977), Jonker (1988, 1990), Meijaard (1991), Schwab (2002) and Schwab & Meijaard (2003). SPACAR is based on finite-element principles laid out by Besseling (1964). SPACAR handles systems of rigid and flexible

	v [m/s]	λ [1/s]
(a)	$v = 0$	$\lambda_{s1} = \pm 3.131\ 643\ 247\ 906\ 56$
	$v = 0$	$\lambda_{s2} = \pm 5.530\ 943\ 717\ 653\ 93$
	$v_d = 0.684\ 283\ 078\ 892\ 46$	$\lambda_d = 3.782\ 904\ 051\ 293\ 20$
	$v_w = 4.292\ 382\ 536\ 341\ 11$	$\lambda_w = 0 \pm 3.435\ 033\ 848\ 661\ 44\ i$
	$v_c = 6.024\ 262\ 015\ 388\ 37$	0

	v [m/s]	$\text{Re}(\lambda_{\text{weave}})$ [1/s]	$\text{Im}(\lambda_{\text{weave}})$ [1/s]
(b)	0	–	–
	1	3.526 961 709 900 70	0.807 740 275 199 30
	2	2.682 345 175 127 45	1.680 662 965 906 75
	3	1.706 756 056 639 75	2.315 824 473 843 25
	4	0.413 253 315 211 25	3.079 108 186 032 06
	5	–0.775 341 882 195 85	4.464 867 713 788 23
	6	–1.526 444 865 841 42	5.876 730 605 987 09
	7	–2.138 756 442 583 62	7.195 259 133 298 05
	8	–2.693 486 835 810 97	8.460 379 713 969 31
	9	–3.216 754 022 524 85	9.693 773 515 317 91
	10	–3.720 168 404 372 87	10.906 811 394 762 87

	v [m/s]	λ_{capsize} [1/s]	$\lambda_{\text{castering}}$ [1/s]
(c)	0	–3.131 643 247 906 56	–5.530 943 717 653 93
	1	–3.134 231 250 665 78	–7.110 080 146 374 42
	2	–3.071 586 456 415 14	–8.673 879 848 317 35
	3	–2.633 661 372 536 67	–10.351 014 672 459 20
	4	–1.429 444 273 613 26	–12.158 614 265 764 47
	5	–0.322 866 429 004 09	–14.078 389 692 798 22
	6	–0.004 066 900 769 70	–16.085 371 230 980 26
	7	0.102 681 705 747 66	–18.157 884 661 252 62
	8	0.143 278 797 657 13	–20.279 408 943 945 69
	9	0.157 901 840 309 17	–22.437 885 590 408 58
	10	0.161 053 386 531 72	–24.624 596 350 174 04

Table 2. (a) Some characteristic values for the forward speed v and the eigenvalues λ from the linearized stability analysis for the benchmark bicycle from figure 1 and table 1. Fourteen digit results are presented for benchmark comparisons. (a) weave speed v_w , capsize speed v_c and the speed with a double root v_d . (b) Complex (weave motion) eigenvalues λ_{weave} in the forward speed range of $0 \leq v \leq 10$ m/s. (c) Real eigenvalues λ .

bodies connected by various joints in both open and closed kinematic loops, and where parts may have rolling contact. SPACAR generates numerically, and solves, full non-linear dynamics equations using minimal coordinates (constraints are eliminated). The SPACAR checks used in this paper use the rigid body, point mass, hinge and rolling-wheel contact features of the program (Schwab & Meijaard 1999, 2003). SPACAR can also find the numeric coefficients for the linearized equations of motion based on a semi-analytic linearization of the non-linear equations. As determined by SPACAR, the entries in the matrices of the linearized equations of motion (5.3) agree to 14 digits with the values presented in §6 a. See Supplementary Appendix 2 for more about the SPACAR checks.

(b) *Equations of motion derived with the symbolic program AutoSim*

We also derived the non-linear governing equations using the multibody dynamics program AutoSim (Sayers 1991a, 1991b). AutoSim is a Lisp (Steele 1990) program mostly based on Kane's (1968) approach. It consists of function definitions and data structures allowing the generation of symbolic equations of motion of rigid-body systems. AutoSim works best for systems of objects connected with prismatic and revolute joints arranged with the topology of a tree (no loops). AutoSim generates equations in the form

$$\dot{\mathbf{q}} = \mathbf{S}(\mathbf{q}, t)\mathbf{u}, \quad \dot{\mathbf{u}} = [\mathbf{M}(\mathbf{q}, t)]^{-1}\mathbf{Q}(\mathbf{q}, \mathbf{u}, t). \quad (7.1)$$

Here, \mathbf{q} are the generalized coordinates, \mathbf{u} are the generalized velocities, \mathbf{S} is the kinematic matrix that relates the rates of the generalized coordinates to the generalized speeds, \mathbf{M} is the system mass matrix, and \mathbf{Q} contains all force terms and velocity dependent inertia terms. Additional constraints are added for closed kinematic loops, special joints and non-holonomic constraints. For example, the closed loop holonomic constraint for both bicycle wheels touching the ground cannot be solved simply in symbolic form for the dependent coordinates, requiring the solution of a quartic polynomial (Psiaki, 1979). An iterative numerical solution for this constraint was used, destroying the purely symbolic nature of the equations.

Strictly speaking, standard AutoSim linearization is not applicable for our system due to the kinematic closed loop of the wheel ground contact. Fortunately, with the laterally symmetric bicycle the dependent coordinate (the pitch angle) remains zero to first order, for which special case the linearization works. The final AutoSim-based linearization output consists of a MatLab script file that numerically calculates the matrices of the linearized equations. The entries in the matrices of the linearized equations of motion (5.3) as determined by the program AutoSim agree to 14 digits with the values presented in §6 a. More details about the AutoSim verification are in Supplementary Appendix 3.

8. Energy conservation and asymptotic stability

When an uncontrolled bicycle is within its stable speed range, roll and steer perturbations die away in a seemingly damped fashion. However, the system has no true damping and conserves energy. As the forward speed is affected only to second order, linearized equations do not capture this energy conservation. Therefore a non-linear dynamic analysis with SPACAR was performed on the benchmark bicycle model to demonstrate the loss of energy from lateral perturbations into forward speed. The initial conditions at $t = 0$ are the upright reference position $(\phi, \delta, \theta_R) = (0, 0, 0)$ at a forward speed of $v = 4.6$ m/s, which is within the stable speed range of the linearized analysis, and an initial angular roll velocity of $\dot{\phi} = 0.5$ rad/s. In the full non-linear equations the final upright forward speed is augmented from the initial speed by an amount determined by the energy in the lateral perturbation. In this case the speed-up was about 0.022 m/s. Figure 4 shows this small increase in the forward speed v while the lateral motions die out, as expected. Figure 4 also shows that the period for the roll and steer oscillations is approximately $T_0 = 1.60$ s, which compares well with the 1.622 s from the linearized stability analysis. The lack of agreement in the second decimal place is from finite-amplitude effects, not

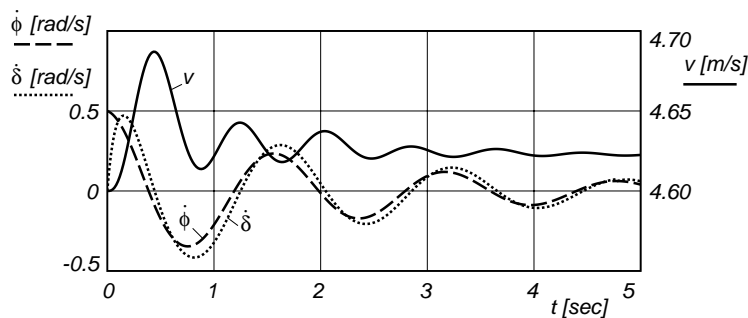

Figure 4. Non-linear dynamic response of the benchmark bicycle from figure 1 and table 1, with the angular roll velocity $\dot{\phi}$, the angular steering velocity $\dot{\delta}$, and the forward speed $v = -\dot{\theta}_R r_R$ for the initial conditions: $(\phi, \delta, \theta_R)_0 = (0, 0, 0)$ and $(\dot{\phi}, \dot{\delta}, v)_0 = (0.5 \text{ rad/s}, 0, 4.6 \text{ m/s})$ for a time period of 5 seconds.

numerical accuracy issues. When the initial lateral velocity is decreased by a factor of 10 the period of motion matches the linear prediction to 4 digits. The steering motion $\dot{\delta}$ has a small phase lag relative to the roll motion $\dot{\phi}$ visible in the solution in figure 4.

9. Conclusions, discussion and future work

We have presented reliable equations for a well-delineated model for more-deeply studying controlled and uncontrolled stability of a bicycle. The equations of motion, equation (5.3) with Appendix A are buttressed by a variety of historical and modern-simulation comparisons and, we feel, can be used with confidence. They can also be used as a check for others who derive their own equations by comparison with:

- a) the analytic form of the coefficients in equation (5.3), or
- b) the numerical value of the coefficients in equation (5.3) using either the general benchmark bicycle parameters of table 1, or the simpler set in the Supplementary Appendix 5, or
- c) the tabulated stability eigenvalues, or
- d) the speed range of self-stability for the benchmark parameters.

This paper firms up Carvalho’s 1897 discovery that asymptotic self-stability of an uncontrolled bicycle is explicable with a sufficiently-complex conservative rigid body dynamics model. It only narrowly answers the question “How does an uncontrolled bicycle stay up?” by showing that it follows from the equations. A simple explanation does not seem possible because the lean and steer are coupled by a combination of several effects including gyroscopic precession, lateral ground-reaction forces at the front wheel ground contact point trailing behind the steering axis, gravity and inertial reactions from the front assembly having center-of-mass off of the steer axis, and from effects associated with the moment of inertia matrix of the front assembly.

The equations here can be the basis for future work addressing how bicycle self-stability does and does not depend on the bicycle design parameters. For example, we hope to dispel some bicycle mythology about the need for mechanical trail or gyroscopic wheels for bicycle self-stability.

Acknowledgements

Technical and editorial comments from Karl Åström, Anindya Chatterjee, Andrew Dressel, Neil Getz, Richard Klein, Anders Lennartsson, David Limebeer, Mark Psiaki, Keith Seffen and Alessandro Saccon have improved the paper. Claudine Pouret at the French Academy of Sciences helped to untangle some of the early history. JPM was supported by the Engineering and Physical Sciences research Council (EPSRC) of the U.K. AR and JMP were supported by an NSF presidential Young Investigator Award and AR further partially supported by NSF biomechanics and robotics grants.

Appendices

These main appendices include

- A) Definitions of the coefficients used in the equations of motion, and
- B) A brief derivation of the governing equations.

Additional supplementary appendices not included with the main paper include

- 1) A review of the history of bicycle dynamics studies,
- 2) A description of the SPACAR validation,
- 3) A description of the AutoSim validation,
- 4) Explanation of the decoupling of lateral from forward motion, and
- 5) A reduced benchmark for use by those with simpler models.

Appendix A. Coefficients of the linearized equations

Here we define the coefficients in equation (5.3). These coefficients and various intermediate variables are expressed in terms of the 25 design parameters (as well as v and g) of table 1 and figure 1. Some intermediate terms defined here are also used in the derivation of the equations of motion in Appendix B. We use the subscript R for the rear wheel, B for the rear frame incorporating the rider Body, H for the front frame including the Handlebar, F for the front wheel, T for the Total system, and A for the front Assembly which is the front frame plus the front wheel. The total mass and the corresponding centre of mass location (with respect to the rear contact point P) are

$$m_T = m_R + m_B + m_H + m_F, \quad (\text{A } 1)$$

$$x_T = (x_B m_B + x_H m_H + w m_F) / m_T, \quad (\text{A } 2)$$

$$z_T = (-r_R m_R + z_B m_B + z_H m_H - r_F m_F) / m_T. \quad (\text{A } 3)$$

For the system as a whole, the relevant mass moments and products of inertia with respect to the rear contact point P along the global axes are

$$I_{Txx} = I_{Rxx} + I_{Bxx} + I_{Hxx} + I_{Fxx} + m_R r_R^2 + m_B z_B^2 + m_H z_H^2 + m_F r_F^2, \quad (\text{A } 4)$$

$$I_{Txz} = I_{Bxz} + I_{Hxz} - m_B x_B z_B - m_H x_H z_H + m_F w r_F. \quad (\text{A } 5)$$

The dependent moments of inertia for the axisymmetric rear wheel and front wheel are

$$I_{Rzz} = I_{Rxx}, \quad I_{Fzz} = I_{Fxx}. \quad (\text{A } 6)$$

Then the moment of inertia for the whole bicycle along the z -axis is

$$I_{Tzz} = I_{Rzz} + I_{Bzz} + I_{Hzz} + I_{Fzz} + m_B x_B^2 + m_H x_H^2 + m_F w^2. \quad (\text{A } 7)$$

The same properties are similarly defined for the front assembly A:

$$m_A = m_H + m_F, \quad (\text{A } 8)$$

$$x_A = (x_H m_H + w m_F) / m_A, \quad z_A = (z_H m_H - r_F m_F) / m_A. \quad (\text{A } 9)$$

The relevant mass moments and products of inertia for the front assembly with respect to the centre of mass of the front assembly along the global axes are

$$I_{Axx} = I_{Hxx} + I_{Fxx} + m_H(z_H - z_A)^2 + m_F(r_F + z_A)^2, \quad (\text{A } 10)$$

$$I_{Axz} = I_{Hxz} - m_H(x_H - x_A)(z_H - z_A) + m_F(w - x_A)(r_F + z_A), \quad (\text{A } 11)$$

$$I_{Azz} = I_{Hzz} + I_{Fzz} + m_H(x_H - x_A)^2 + m_F(w - x_A)^2. \quad (\text{A } 12)$$

Let $\boldsymbol{\lambda} = (\sin \lambda, 0, \cos \lambda)^T$ be a unit vector pointing down along the steer axis where λ is the angle in the xz -plane between the downward steering axis and the $+z$ direction. The centre of mass of the front assembly is ahead of the steering axis by perpendicular distance

$$u_A = (x_A - w - c) \cos \lambda - z_A \sin \lambda. \quad (\text{A } 13)$$

For the front assembly three special inertia quantities are needed: the moment of inertia about the steer axis and the products of inertia relative to crossed, skew axes, taken about the points where they intersect. The latter give the torque about one axis due to angular acceleration about the other. For example, the λx component is taken about the point where the steer axis intersects the ground plane. It includes a part from I_A operating on unit vectors along the steer axis and along x , and also a parallel axis term based on the distance of m_A from each of those axes.

$$I_{A\lambda\lambda} = m_A u_A^2 + I_{Axx} \sin^2 \lambda + 2I_{Axz} \sin \lambda \cos \lambda + I_{Azz} \cos^2 \lambda, \quad (\text{A } 14)$$

$$I_{A\lambda x} = -m_A u_A z_A + I_{Axx} \sin \lambda + I_{Axz} \cos \lambda, \quad (\text{A } 15)$$

$$I_{A\lambda z} = m_A u_A x_A + I_{Axz} \sin \lambda + I_{Azz} \cos \lambda. \quad (\text{A } 16)$$

The ratio of the mechanical trail (i.e., the perpendicular distance that the front wheel contact point is behind the steering axis) to the wheel base is

$$\mu = (c/w) \cos \lambda. \quad (\text{A } 17)$$

The rear and front wheel angular momenta along the y -axis, divided by the forward speed, together with their sum form the gyrostatic coefficients:

$$S_R = I_{Ryy}/r_R, \quad S_F = I_{Fyy}/r_F, \quad S_T = S_R + S_F. \quad (\text{A } 18)$$

We define a frequently appearing static moment term as

$$S_A = m_A u_A + \mu m_T x_T. \quad (\text{A } 19)$$

The entries in the linearized equations of motion can now be formed. The mass moments of inertia

$$\begin{aligned} M_{\phi\phi} &= I_{Txx} \quad , \quad M_{\phi\delta} = I_{A\lambda x} + \mu I_{Txx}, \\ M_{\delta\phi} &= M_{\phi\delta} \quad , \quad M_{\delta\delta} = I_{A\lambda\lambda} + 2\mu I_{A\lambda z} + \mu^2 I_{Tzz}, \end{aligned} \quad (\text{A } 20)$$

are elements of the symmetric mass matrix $\mathbf{M} = \begin{bmatrix} M_{\phi\phi} & M_{\phi\delta} \\ M_{\delta\phi} & M_{\delta\delta} \end{bmatrix}$. (A 21)

The gravity-dependent stiffness terms (to be multiplied by g) are

$$\begin{aligned} K_{0\phi\phi} &= m_{\text{T}}z_{\text{T}} & , & & K_{0\phi\delta} &= -S_{\text{A}}, \\ K_{0\delta\phi} &= K_{0\phi\delta} & , & & K_{0\delta\delta} &= -S_{\text{A}} \sin \lambda, \end{aligned} \quad (\text{A } 22)$$

which form the stiffness matrix $\mathbf{K}_0 = \begin{bmatrix} K_{0\phi\phi} & K_{0\phi\delta} \\ K_{0\delta\phi} & K_{0\delta\delta} \end{bmatrix}$. (A 23)

The velocity-dependent stiffness terms (to be multiplied by v^2) are

$$\begin{aligned} K_{2\phi\phi} &= 0 & , & & K_{2\phi\delta} &= ((S_{\text{T}} - m_{\text{T}}z_{\text{T}})/w) \cos \lambda, \\ K_{2\delta\phi} &= 0 & , & & K_{2\delta\delta} &= ((S_{\text{A}} + S_{\text{F}} \sin \lambda)/w) \cos \lambda, \end{aligned} \quad (\text{A } 24)$$

which form the stiffness matrix $\mathbf{K}_2 = \begin{bmatrix} K_{2\phi\phi} & K_{2\phi\delta} \\ K_{2\delta\phi} & K_{2\delta\delta} \end{bmatrix}$. (A 25)

In the equations we use $\mathbf{K} = g\mathbf{K}_0 + v^2\mathbf{K}_2$. Finally the ‘‘damping’’ terms are

$$\begin{aligned} C_{1\phi\phi} &= 0, & C_{1\phi\delta} &= \mu S_{\text{T}} + S_{\text{F}} \cos \lambda + (I_{\text{T}xz}/w) \cos \lambda - \mu m_{\text{T}}z_{\text{T}}, & (\text{A } 26) \\ C_{1\delta\phi} &= -(\mu S_{\text{T}} + S_{\text{F}} \cos \lambda), & C_{1\delta\delta} &= (I_{\text{A}\lambda z}/w) \cos \lambda + \mu(S_{\text{A}} + (I_{\text{T}zz}/w) \cos \lambda), \end{aligned}$$

which form $\mathbf{C}_1 = \begin{bmatrix} C_{1\phi\phi} & C_{1\phi\delta} \\ C_{1\delta\phi} & C_{1\delta\delta} \end{bmatrix}$ where we use $\mathbf{C} = v\mathbf{C}_1$. (A 27)

Appendix B. Derivation of the linearized equations of motion

The following brief derivation of the linearized equations of motion is based on Papadopoulos (1987). All derivations to date, including this one, involve *ad hoc* linearization as opposed to linearization of full nonlinear equations. No-one has linearized the full implicit non-linear equations (implicit because there is no reasonably simple closed form expression for the closed kinematic chain) into an explicit analytical form either by hand or computer algebra.

For a bicycle freely rolling forward on a plane, slightly perturbed from upright straight ahead motion, we wish to find the linear equations of motion governing the two lateral degrees of freedom: rightward lean ϕ of the rear frame, and rightward steer δ of the handlebars. The linearized equation of motion for forward motion is simple two-dimensional mechanics and has already been given in equation (5.2).

We take the bicycle to be near to and approximately parallel to the global x -axis. The bicycle’s position and configuration, with respect to lateral linearized dynamics, are defined by the variables y_{P} , ψ , ϕ and δ . In this derivation we assume not only ϕ and δ but also $\dot{y}_{\text{P}}/v \approx \psi$ small, such that only first order consequences of the configuration variables need be kept.

Forces of importance to lateral linearized dynamics include: gravity at each body's mass centre, positive in z ; vertical ground reaction force at the front wheel: $-m_T g x_T / w$; horizontal ground reaction force F_{Fy} at the front wheel, approximately in the y direction; a roll moment $T_{B\phi}$ applied to the rear frame and tending to roll the bicycle to the right about the line connecting the wheel contacts; a steer torque pair $T_{H\delta}$, applied positively to the handlebars so as to urge them rightward, and also applied negatively to the rear frame.

Initially we replace the non-holonomic rolling constraints with to-be-determined horizontal forces at the front and rear contacts that are perpendicular to the wheel headings. We apply angular momentum balance to various subsystems about some axis \mathbf{u} .

$$\sum_{i \in \{\text{bodies}\}} [\mathbf{r}_i \times \mathbf{a}_i m_i + \mathbf{I}_i \dot{\boldsymbol{\omega}}_i + \boldsymbol{\omega}_i \times (\mathbf{I}_i \boldsymbol{\omega}_i)] \cdot \mathbf{u} = \sum_{j \in \{\text{applied forces}\}} [\mathbf{r}_j \times \mathbf{F}_j] \cdot \mathbf{u}$$

The left side of each equation is the rate of change of angular momentum about the given axis. The right side is the torque of the external forces (gravity, loads and ground reactions). The positions \mathbf{r}_i and \mathbf{r}_j of the bodies' centres of mass and of applied forces, respectively, are relative to any point on the axis. The bodies' angular velocities and accelerations $\boldsymbol{\omega}_i, \dot{\boldsymbol{\omega}}_i$ and \mathbf{a}_i are expressed in terms of first and second derivatives of lateral displacement, yaw, lean and steer.

Roll angular momentum balance for the whole bicycle about a fixed axis in the ground plane that is instantaneously aligned with the line where the frame plane intersects the ground (this axis does not generally go through the front ground contact point) gives:

$$\begin{aligned} -m_T \ddot{y}_P z_T + I_{Txx} \ddot{\phi} + I_{Txx} \ddot{\psi} + I_{A\lambda x} \ddot{\delta} + \dot{\psi} v S_T + \dot{\delta} v S_F \cos \lambda \\ = T_{B\phi} - g m_T z_T \phi + g S_A \delta. \end{aligned} \quad (\text{B1})$$

In addition to the applied $T_{B\phi}$ the right-hand side has a lean moment from gravitational forces due to lateral lean-induced sideways displacement of the bicycle parts, and a term due to lateral displacement of front-contact vertical ground reaction relative to the axis. Next, yaw angular momentum balance for the whole bicycle about a fixed vertical axis that instantaneously passes through the rear wheel contact gives

$$m_T \ddot{y}_P x_T + I_{Txx} \ddot{\phi} + I_{Tzz} \ddot{\psi} + I_{A\lambda z} \ddot{\delta} - \dot{\phi} v S_T - \dot{\delta} v S_F \sin \lambda = w F_{Fy}. \quad (\text{B2})$$

The only external yaw torque is from the yet-to-be-eliminated lateral ground force at the front contact. Lastly, steer angular momentum balance for the front assembly about a fixed axis that is instantaneously aligned with the steering axis gives

$$\begin{aligned} m_A \ddot{y}_P u_A + I_{A\lambda x} \ddot{\phi} + I_{A\lambda z} \ddot{\psi} + I_{A\lambda\lambda} \ddot{\delta} + v S_F (-\dot{\phi} \cos \lambda + \dot{\psi} \sin \lambda) \\ = T_{H\delta} - c F_{Fy} \cos \lambda + g(\phi + \delta \sin \lambda) S_A. \end{aligned} \quad (\text{B3})$$

In addition to the applied steering torque $T_{H\delta}$ there are torques from both vertical (gravity reactions) and lateral (yet to be determined from constraints) forces at the front contact, and from downwards gravity forces on the front assembly. The final steps are to combine equations (B2) and (B3) in order to eliminate the unknown

front-wheel lateral reaction force F_{Fy} , leaving two equations; and then to use the rolling constraints to eliminate ψ and y_P and their time derivatives, leaving just the lean and steer second derivatives as the two unknown variables.

Each rolling-contact lateral constraint is expressed as a rate of change of lateral position due to velocity and heading (yaw). For the rear,

$$\dot{y}_P = v\psi. \quad (\text{B } 4)$$

Equivalently for the front, where $y_Q = y_P + w\psi - c\delta \cos \lambda$, and the front frame heading is the rear frame yaw augmented by the true (ground) steer angle:

$$d(y_P + w\psi - c\delta \cos \lambda)/dt = v(\psi + \delta \cos \lambda). \quad (\text{B } 5)$$

We subtract (B 4) from (B 5) to get an expression for $\dot{\psi}$ in terms of δ and $\dot{\delta}$ and then differentiate

$$\dot{\psi} = ((v\delta + c\dot{\delta})/w) \cos \lambda \quad \Rightarrow \quad \ddot{\psi} = ((v\dot{\delta} + c\ddot{\delta})/w) \cos \lambda. \quad (\text{B } 6)$$

Finally we differentiate (B 4) and use (B 6) to get an expression for \ddot{y}_P ,

$$\ddot{y}_P = ((v^2\delta + vc\dot{\delta})/w) \cos \lambda. \quad (\text{B } 7)$$

Substituting (B 6) and (B 7) into (B 1), we get an expression in ϕ , $\ddot{\phi}$ and δ , $\dot{\delta}$ and $\ddot{\delta}$, with a right-hand side equal to $T_{B\phi}$. This is called the *lean equation*. Eliminating F_{Fy} from (B 2) and (B 3), then again substituting (B 6) and (B 7), we will have another expression in ϕ and δ and their derivatives, where the right-hand side is $T_{H\delta}$ (the steer torque). This is called the *steer equation*. These two equations are presented in matrix form in (5.3).

Note that from general dynamics principles we know that the forcing terms can be defined by virtual power. Thus we may assume that the torques used in this angular momentum equations may be replaced with those defined by the virtual power equation (5.1). Therefore, where this derivation uses the torques $T_{B\phi}$ and $T_{H\delta}$ the generalized forces T_ϕ and T_δ actually apply.

Since ψ and y_P do not appear in the final equation, there is no need for the bicycle to be aligned with the global coordinate system used in figure 2. Thus x , y and ψ can be arbitrarily large and the bicycle can be at any position on the plane at any heading. For simulation and visualization purpose we can calculate the ignorable coordinates x_P , y_P and ψ by integration. The equation for the yaw angle ψ is the first of (B 6). Then the rear contact point is described by

$$\dot{x}_P = v \cos \psi, \quad \dot{y}_P = v \sin \psi. \quad (\text{B } 8)$$

Note the large-angle form for \dot{y}_P here as opposed to the small angle form (B 4) used to derive the equations of motion. (This situation is somewhat analogous to, say, the classical elastica where the lateral displacements and angles used in the strain calculation are small yet the lateral displacements and angles of the elastica overall can be arbitrarily large.)

Intermediate results may be used to calculate constraint forces for, e.g., tire modelling. For example equation (B 2) determines the horizontal lateral force at the front contact. And lateral linear momentum balance can be added to find the horizontal lateral force at the rear wheel contact.

References

- Appell, P.E. 1896 *Traité de Mécanique Rationnelle*, Vol. II, pp.297–302, 1st edn. Paris: Gauthier-Villars.
- Åström, K.J., Klein, R.E. & Lennartsson, A. 2005 Bicycle dynamics and control: Adapted bicycles for education and research. *IEEE Control Systems Magazine* **25**(4), 26–47.
- Basu-Mandal, P., Chatterjee A. and Papadopoulos, J.,2006 Hands-free Circular Motions of a Benchmark Bicycle, in preparation for Proc. R. Soc. A.
- Besseling, J. F. 1964 The complete analogy between the matrix equations and the continuous field equations of structural analysis. In *International symposium on analogue and digital techniques applied to aeronautics: Proceedings*, Presses Académiques Européennes, Bruxelles, pp. 223–242.
- Bouasse, H. 1910 *Cours de Mécanique Rationnelle et Expérimentale*, part 2, pp. 620–623. Paris: Ch. Delagrave.
- Bourlet, C. 1899 Étude théorique sur la bicyclette, *Bulletin de la Société Mathématique de France* **27**, part I pp. 47–67, Part II p. 76–96. (Originally submitted in 1897 for the Prix Fourneyron, awarded first place 1898.)
- Boussinesq, J. 1899a Aperçu sur la théorie de la bicyclette, *Journal de Mathématiques Pures et Appliquées* **5**, pp. 117–135.
- Boussinesq, J. 1899b Complément à une étude récente concernant la théorie de la bicyclette (1): influence, sur l'équilibre, des mouvements latéraux spontanés du cavalier, *Journal de Mathématiques Pures et Appliquées*, **5**, pp. 217–232.
- Bower, G. S. 1915 Steering and stability of single-track vehicles. *The Automobile Engineer* **V**, 280–283.
- Carvallo, E. 1899 (awarded Prix Fourneyron 1898, submitted 1897). Also published as Théorie du mouvement du Monocycle et de la Bicyclette. *Journal de L'École Polytechnique*, Series 2, Part 1, Volume 5, “Cerceau et Monocycle”, 1900, pp. 119–188, 1900. Part 2, Volume 6, “Théorie de la Bicyclette”, pp. 1–118, 1901.
- Collins, R. N. 1963 A mathematical analysis of the stability of two-wheeled vehicles. Ph.D. thesis, Dept. of Mechanical Engineering, University of Wisconsin.
- Cox, A. J. 1998 Angular momentum and motorcycle counter-steering: a discussion and demonstration. *American Journal of Physics* **66**(11), pp. 1018–1019.
- Den Hartog, J. P. 1948 *Mechanics*, article 61. New York and London: McGraw-Hill.
- Dikarev, E.D., Dikareva, S. B., & Fufaev N.A. 1981 Effect of inclination of steering axis and stagger of the front wheel on stability of motion of a bicycle. *Izv. Akad. Nauk. SSSR. Mekhanika Tverdogo Tela* **16**(1), pp. 69–73. (Engl. Mechanics of Solids, **16**, p. 60)
- Döhring, E. 1953 Über die Stabilität und die Lenkkräfte von Einspurfahrzeugen. Ph.D. thesis, University of Technology Braunschweig, Germany.
- Döhring, E. 1955 Die Stabilität von Einspurfahrzeugen. *Forschung Ing.-Wes.* **21**(2), 50–62. (Transl. by J. Lotsof, Stability of single-track vehicles, March 1957) (available at <http://ruina.tam.cornell.edu/research/>)
- Eaton, D. J. 1973 Man-machine dynamics in the stabilization of single-track vehicles. Ph.D. thesis, University of Michigan.
- Fajans, J 2000 Steering in bicycles and motorcycles, *Am. J. Phys.* **68**(7), July, 654–659
- Franke, G., Suhr, W. & Rieß, F. 1990 An advanced model of bicycle dynamics. *Eur. J. Physics.* **11**(2), 116–121.
- Ge, Zheng-Ming 1966 Kinematical and Dynamic Studies of a Bicycle, Publishing House of Shanghai Chiao Tung University. <http://wwwwdata.me.nctu.edu.tw/dynamic/chaos.htm> (click on director)

- Getz, N. H. & Marsden, J. E. 1995 Control for an autonomous bicycle. In *IEEE Conference on Robotics and Automation. 21–27 May 1995, Nagoya, Japan*.
- Haag, J. 1955 Oscillatory motions (Volume 2), Presses Universitaires de France, translation published by Wadsworth Publishing Company, Belmont CA.
- Hand, R. S. 1988 Comparisons and stability analysis of linearized equations of motion for a basic bicycle model. M.Sc. thesis, Cornell University.
(available at <http://ruina.tam.cornell.edu/research/>)
- Herfkens, B. D. 1949 De stabiliteit van het rijwiel, (In dutch, The stability of the bicycle.) Report S-98-247-50-10-'49, Instituut voor rijwielontwikkeling, Delft, The Netherlands.
(available at our website.)
- Herlihy, D. V. 2004 *Bicycle: The history*, New Haven, CT: Yale University Press.
- Higbie, J. 1974 The motorcycle as a gyroscope, *American Journal of Physics* **42**(8), pp. 701–702.
- Hubbard, M. 1979. Lateral dynamics and stability of the skateboard. *Journal of Applied Mechanics*, 46:931–936.
- Jones, A. T. 1942 Physics and Bicycles, *American Journal of Physics*, **10**(6), pp. 332–333.
- Jones, D. E. H. 1970 The Stability of the bicycle. *Physics Today* **23**(3), 34–40.
- Jonker, J. B. 1988 A finite element dynamic analysis of flexible spatial mechanisms and manipulators. Ph.D. thesis, Delft University of Technology, Delft.
- Jonker, J. B. & Meijaard, J. P. 1990 SPACAR—Computer program for dynamic analysis of flexible spatial mechanisms and manipulators. In *Multibody Systems Handbook* (ed. W. Schiehlen). Berlin: Springer-Verlag, pp. 123–143.
- Kane, T. R. 1968 *Dynamics*. New York: Holt, Rinehart and Winston.
- Kirshner, D. 1980 Some nonexplanations of bicycle stability. *American Journal of Physics*, **48**(1), pp. 36–38.
- Klein, F. & Sommerfeld, A. 1910 *Über die Theorie des Kreisels*, Ch. IX, Section 8, Stabilität des Fahrrads, by F. Noether, pp. 863–884. Leipzig: Teubner. (English translation available at [http://ruina.tam.cornell.edu/research.](http://ruina.tam.cornell.edu/research/))
- Koenen, C. 1983 The dynamic behaviour of a motorcycle when running straight ahead and when cornering. Ph.D. thesis, Delft University of Technology, Delft.
- Kondo, M., Nagaoka, A., and Yoshimura, F. 1963 Theoretical study on the running stability of the two-wheelers. *Trans S.A.E. Japan* **17**(1), pp. 8–18.
- Kooijman, J. D. G. 2006 Experimental validation of a model for the motion of an uncontrolled bicycle, M.Sc. thesis, Delft University of Technology.
- Lallement, P. 1866 Improvement in velocipedes, U.S. Patent 59915.
- Le Hénaff, Y. 1987 Dynamical stability of the bicycle, *Eur. J. Phys.*, **8**(3), pp. 207–210.
- Lennartsson, A. 1999 Efficient multibody dynamics, Ph.D. thesis, Royal Institute of Technology, Stockholm.
- Limebeer, D. J. N. & Sharp, R. S., 2006. Bicycles, Motorcycles and Models, *IEEE Control Systems Magazine*, **26**(5), pp. 34–61.
- Lobas, L. G. 1978 Controlled and programmed motion of a bicycle on a plane. *Mechanics of solids* **13**(6), 18. (Transl. by Allerton Press [authors name misspelled into “Gobas”], Cited in translation as *Izv. AN SSSR. “Mekhanika Tverdogo Tela,”* Vol. 13, No. 6, pp. 22–28, 1978.)
- Ločjanskii (or Loitsyanskii), L. G. & Lur’e (or Lurie), A. I. 1934 *Course of Theoretical Mechanics*, Vol. 3, ONTI, Moscow, 1934; Vol. 2, 5th edn., GITTL, Moscow, 1955.
- Lowell, J & McKell, H. D. 1982 The stability of bicycles. *American Journal of Physics* **50**(12), 1106–1112.
- Manning, J. R. 1951 The dynamical stability of bicycles, Report RN/1605/JRM, Department of Scientific and Industrial Research, Road Research Laboratory, Crowthorne, Berkshire, UK.

- Maunsell, F. G. 1946 Why does a bicycle keep upright? *The Mathematical Gazette* **30**(291), pp. 195–199.
- Mears, B. C. 1988 Open loop aspects of two wheeled vehicle stability characteristics. Ph.D. thesis, University of Illinois at Urbana–Champaign, IL.
- Meijaard, J. P. 1991 Direct determination of periodic solutions of the dynamical equations of flexible mechanisms and manipulators. *International Journal for Numerical Methods in Engineering* **32**, 1691–1710.
- Meijaard, J. P. 2004 Derivation of the linearized equations for an uncontrolled bicycle. Internal report University of Nottingham, UK.
- Neĭmark, Ju. I. & Fufaev, N. A. 1972 *Dynamics of Nonholonomic Systems*. Providence, RI: A.M.S. (Transl. from the Russian edition, Nauka, Moscow, 1967.)
- Olsen, J. & Papadopoulos, J.M. 1988 Bicycle Dynamics - The Meaning Behind the Math. *Bike Tech*, Dec, pp. 13–15.
- Papadopoulos, J. M. 1987 Bicycle steering dynamics and self-stability: A summary report on work in progress. Technical report, Cornell Bicycle Research Project, Cornell University, pp. 1–23.
(available with other related reports at: <http://ruina.tam.cornell.edu/research/>).
- Patterson, B. 1993 Chronicles of the Lords of the Chainring.
- Pearsall, R. H. 1922 The stability of a bicycle. *The Institution of Automobile Engineers*, Proceeding Session 1922–23 Part I, Vol. XVII, pp. 395–404.
- Psiaki, M. L. 1979 Bicycle stability: A mathematical and numerical analysis. Undergraduate thesis, Physics Dept., Princeton University, NJ.
- Rankine, W. J. M. 1869 On the dynamical principles of the motion of velocipedes. *The Engineer* **28**, pp. 79, 129, 153, 175, **29**(1870), pp. 2.
- Rice, R. S. & Roland, R. D. 1970 An evaluation of the performance and handling qualities of bicycles. Cornell Aero. Lab. Report no. VJ-2888-K.
- Rice, R. S. 1974 Bicycle dynamics simplified steady state response characteristics and stability indices, Cornell Aero. Lab. Report no. ZN-5431-V-1.
- Rice, R. S. 1976 Bicycle dynamics simplified dynamic stability analysis, Cornell Aero. Lab. Report no. ZN-5921-V-2.
- Roland, R. D. 1973 Computer simulation of bicycle dynamics. *Mechanics and Sport* **4**, ASME, pp. 35–83.
- Roland, R. D. & Lynch, J. P. 1972 Bicycle dynamics tire characteristics and rider modeling. Cornell Aero. Lab. Report no. YA-3063-K-2.
- Roland, R. D. & Massing, D. E. 1971 A digital computer simulation of bicycle dynamics. Cornell Aero. Lab. Report no. YA-3063-K-1.
- Routh, G. R. R. 1899 On the Motion of a Bicycle. *The Messenger of Mathematics* **28**, pp. 151–169.
- Ruina, A. 1998 Non-holonomic stability aspects of piecewise holonomic systems. *Reports on Mathematical Physics*, **42**(1/2), pp. 91–100.
- SAE (Society of Automotive Engineers) 2001 Vehicle dynamics Terminology–SAE J670e. *2001 SAE Handbook*, SAE international, Warrendale, PA.
- Sayers, M. W. 1991a Symbolic computer language for multibody systems. *Journal of Guidance, Control, and Dynamics* **14**, 1153–1163.
- Sayers, M. W. 1991b Symbolic vector/dyadic multibody formalism for tree-topology systems. *Journal of Guidance, Control, and Dynamics* **14**, 1240–1250.
- Schwab, A. L. 2002 Dynamics of flexible multibody systems. Ph.D. thesis, Delft University of Technology, Delft.
- Schwab, A. L. & Meijaard, J. P. 1999 Dynamics of flexible multibody systems having rolling contact: Application of the wheel element to the dynamics of road vehicles. *Vehicle System Dynamics Supplement* **33**, 338–349.

- Schwab, A. L. & Meijaard, J. P. 2003 Dynamics of flexible multibody systems with non-holonomic constraints: A finite element approach. *Multibody System Dynamics* **10**, 107–123.
- Schwab, A. L., Meijaard, J. P. & Papadopoulos, J. M. 2005 Benchmark results on the linearized equations of motion of an uncontrolled bicycle. *KSME International Journal of Mechanical Science and Technology* **19**(1), 292–304.
- Sharp, A. 1896 *Bicycles and tricycles; an elementary treatise on their design and construction*, London: Longmans Green.
- Sharp, R. S. 1971 The stability and control of motorcycles. *Journal of Mechanical Engineering Science* **13**(5), 316–329.
- Sharp, R. S. 1985 The lateral dynamics of motorcycles and bicycles. *Vehicle System Dynamics* **14**, 265–283.
- Singh, D. V. 1964 Advanced concepts of the stability of two-wheeled vehicle-application of mathematical analysis to actual vehicles. Ph.D. Thesis, Dept. of Mechanical Engineering, University of Wisconsin.
- Singh, D. V. & Goel, V. K. 1971 Stability of Rajdoot Scooter. *SAE Paper no. 710273*.
- Singh, D. V. & Goel, V. K. 1975 Stability of single track vehicles. In *Proceedings of IUTAM Symposium, The Dynamics of vehicles on roads and on railway tracks, Delft, the Netherlands, Aug 18–22, 1975*, pp. 187–196.
- Steele Jr, G. L. 1990 *Common Lisp, The Language*, 2nd edn., Digital Press, U.S.A.
- Timoshenko, S. & Young, D. H. 1948 *Advanced Dynamics*. New York: McGraw-Hill.
- Van der Werff, K. 1977 Kinematic and dynamic analysis of mechanisms, a finite element approach. Ph.D. thesis, Delft University of Technology, Delft.
- Van Zytveld, P. J. 1975 A method for the automatic stabilization of an unmanned bicycle. M.Sc. thesis, Dept. of Aeronautics and Astronautics, Stanford University, CA. (available at <http://ruina.tam.cornell.edu/research/>.)
- Wallace, J. 1929 The super-sports motor cycle (with an appendix on steering layout). *Institution of Automobile Engineers, Proceedings* **24**, , November, pp. 161–217
- Weir, D. H. 1972 Motorcycle handling dynamics and rider control and the effect of design configuration on response and performance. Ph.D. thesis, University of California, LA.
- Weir, D. H. & Zellner, J. W. 1978 Lateral-directional motorcycle dynamics and rider control. Technical report no. 780304, Society of Automotive Engineers, Warrendale, PA.
- Whipple, F. J. W. 1899 The Stability of the Motion of a Bicycle. *The Quarterly Journal of Pure and Applied Mathematics* **30**, 312–348.
- Wilson, D. G. 2004 *Bicycling science*, 3rd edn. with contributions by Jim Papadopoulos. Cambridge, MA: MIT Press.

Supplementary Appendices

associated with but not printed with the paper

*Linearized dynamics equations for the balance and steer of
a bicycle: a benchmark and review*

by

J. P. Meijaard, J. M. Papadopoulos, A. Ruina and A. L. Schwab

Introduction

Appendices in the main body of the paper (not included below) are

- A) Definitions of the coefficients used in the equations of motion, and
- B) A brief derivation of the governing equations.

These supplementary appendices (below) include:

1. A detailed history of bicycle dynamics studies with an expanded bibliography.
2. An explanation of the verification of the linearized equations with the aid of the numerical dynamics package SPACAR.
3. An explanation of the verification of the linearized equations using the symbolic algebra package AutoSim.
4. An explanation of how lateral symmetry decouples lateral and forward motion and gives $\dot{v} = 0$ as one of the linearized equations of motion.
5. A reduced benchmark for use by those who have a less general bicycle simulation and want to use the results here for validation.

1. History of bicycle steer and dynamics studies

“Even now, after we’ve been building them for 100 years, it’s very difficult to understand just why a bicycle works - it’s even difficult to formulate it as a mathematical problem.” — Freeman Dyson interviewed by Stewart Brand in Wired News, February 1998.

This appendix builds on Hand (1988) and is the source of the brief literature review in the main body of the paper. We divide the literature on bicycle dynamics in three categories:

- a) Qualitative explanations of stability and self-stability that do not use the differential equations of motion.
- b) Dynamical analyses that use any number of simplifications which preclude study of hands-free self-stability.
- c) Equations of motion describing a model that has, in principle, enough complexity to predict hands-free self-stability.

The historical discussion below is in chronological order within each of the three categories above.

(a) Qualitative discussions of stability

Basic features of balance by means of controlled steering are accessible without detailed equations, and are reasonably described in many papers. In contrast, the self-stability of a bicycle involves complex dynamic phenomena that seem to us to be beyond precise description without appeal to correct governing equations. Thus the qualitative discussions of self-stability below are necessarily less definitive.

1866 Lallement’s velocipede-improvement U.S. Patent, which is on the addition of front-wheel pedals (as opposed to pushing the feet on the ground), includes a concise explanation of balancing by steering: “If the carriage is inclined to lean to the right, turn the wheel [to the right], which throws the carriage over to the left...”. Within five years, the U. S. patent literature begins to show pictures of bicycles further improved with trail and an inclined steering axis. Whether or not these improvements conveyed genuine self-stability is not known.

1869 W. J. Macquorn Rankine, engineer and thermodynamics theorist, presents semi-quantitative observations on lean and steer of a velocipede. This seems to be the first description of ‘countersteering’ — briefly turning to the left to generate the rightward lean necessary for a steady rightward turn. The Wright brothers were later obsessed with this counter-steering aspect of bicycle control (see quote in, e.g., Åström *et al.* (2005)). Rankine discusses steer only by means of rider control and seems to have been unaware of the possibility of self-stability.

1896 Archibald Sharp, an engineering lecturer at what was to become Imperial College, publishes his book covering nearly all technical aspects of bicycle

theory and practice, including sections on stability for which he earned an honorable mention in the 1898 Prix Fourneyron (see Bourlet below). Sharp also later authored the classic 11th edition Britannica (1910) entry on bicycles. In calculating the handlebar torque required to maintain a steady turn, Sharp's equation (6) is wrong, first by the typographical error of a sign change in the second parentheses, and second by neglecting the centrifugal force on the mass centre of the front assembly. Sharp also neglects precessional torque on the front wheel. However, Sharp explicitly recognizes the mechanical trail and implicitly recognizes the quantity we call S_A .

Sharp developed his equation to investigate no-hands riding. Sharp concludes, correctly in part (see Jones 1970 below), that the no-hands rider exercises control of steering through upper-body lean causing frame lean, leading to gyroscopic precession of the front wheel. A rider can thus control this precession and make corrective turns much like he or she would with direct handlebar torques. Sharp seemed unaware of the possibility of bicycle self-stability.

1896 Appell, in his dynamics textbook, summarizes Bourlet's analysis (see category (b) below) of balancing and steering a velocipede. Surprisingly, this master of the differential equations governing dynamics includes none in his discussion of bicycles.

The later 1890s are a period when numerous mathematical analyses are initiated. Appell mentions a few both in later editions of his textbook (1899–1952), and in a monograph (1899) on the nonholonomic mechanics of rolling bodies.

1920 Grammel provides some discussion of gyroscopic moments in bicycling, but provides no equations of motion.

1929 Wallace's long technical paper on motorcycle design contains thoughtful qualitative discussions on his predictions about the handling characteristics of various motorcycle designs (pp. 177–184). He examines steer torque, including the contribution of toroidal tires and gyroscopic torques. Wallace's analysis of non-linear geometric effects (pp. 185–212) erroneously assumes no pitch of the rear frame due to steering.

1946 Maunsell quantitatively estimates the relative sizes of many of the potential effects that can cause an uncontrolled bicycle to turn into a fall. Although the paper does not use complex modelling, it clearly lays out and partially answers many questions about bicycle stability. Maunsell is candid about the difficulty of using full dynamics equations "I have not yet had time to follow out in full the long and involved calculations of [Carvallo's] paper... I hope to do so in the future." (Carvallo is discussed in section (c) below).

1970 David E. H. Jones's Physics Today article (re-printed in 2006) is perhaps the single best-known paper on bicycle stability. With simple experiments Jones showed that, for the bicycles he tried, both front-wheel spin momentum and positive mechanical trail were needed for self-stability. Jones also observed that a rider can easily balance almost any bicycle that was not self-stable by turning the handlebars appropriately. But when riding no-hands, Jones had difficulty stabilizing a bicycle whose front-wheel gyroscopic terms

were cancelled by an added, counter-spinning wheel. And Jones was unable to master no-hands balance of a bicycle with negative trail. Jones's experimental observations indicate useful trends, but do not seem to represent precise boundaries on what is or can be stable or controlled. On the theoretical side Jones wanted to counter the widely-quoted simple gyroscopic explanations of no-hands bicycle control presented for example in Sharp (1896) above and un-controlled no-hands bicycle stability presented, for example, in Sommerfeld & Klein (1910). His experiments with a variety of bicycles pointed to mechanical trail as another important factor in bicycle stability. Jones did no dynamical modelling, and focused only on trail's effect on steer torque as a function of lean. His thought was that the "static" torque would define the steering tendency for a leaned bicycle, and thereby explain self-stability. In effect Jones explored only the gravitational-potential part of one entry in the stiffness matrix, while also ignoring the velocity-dependent centrifugal and gyroscopic terms. A variety of subsequent investigators have built on Jones's potential-energy treatment.

1942-98 Various other qualitative discussions, none making use of already published governing dynamics equations, were authored by Arthur Jones (1942), Den Hartog (1948), Higbie (1974), Kirshner (1980), Le Hénaff (1987), and Cox (1998). Most of these papers, somewhat like David Jones (1970), describe one or another term in the dynamics equations (e.g., centripetal forces or gyroscopic terms) but overstate, we think, their singular role in bicycle stability.

1984 Foale's book comprehensively explores factors affecting motorcycle handling.

1988 Olsen & Papadopoulos' qualitative article discusses aspects of dynamic modelling based on the uncontrolled bicycle equations in Papadopoulos (1987). Supplementary material for that article is available on the internet.

1993 Patterson developed a series of dynamically based design rules for improving rider control authority.

1999 Cossalter presented an entire book with qualitative explanations of his decades of quantitative modelling work on motorcycle handling.

2004 Wilson's *Bicycling Science* includes a chapter by Papadopoulos which qualitatively discusses bicycle stability.

(b) *Simplified analyses that use dynamics*

Simplified dynamic models have appeared from the mid 1890s to the present day. These papers use one or more of the following 3 types of specializations:

i) Simplified geometry and/or mass distribution. In these models some collection of the following assumptions are made:

- inertia axes of rear frame are vertical/horizontal
- inertia axes of front frame are vertical/horizontal or aligned with steer axis

- no spin angular momentum of wheels
- point masses for the frames and/or wheels
- massless wheels
- massless front assembly
- vertical steer axis
- zero trail
- vanishing wheel radii

Such simplified models are generally incapable of self-stability, as one can deduce by plugging their parameters into the eigenvalue calculations outlined in the present paper.

ii) No steer dynamics because steer angle is fully controlled by the rider.

In these models balance is effected entirely as a result of rider-controlled steering angle, and the steer angle δ has no uncontrolled dynamics. For these models there is no need to derive the relatively less intuitive equation for steer dynamics. Appropriately controlled steer angle is indeed the only way to stabilize many simplified bikes. Because velocipedes (primitive bicycles with vertical steer axis, no trail, and front-assembly essentially on the steer axis) were not self-stable, it is natural that all of the early mathematical analyses incorporated a controlled-steering assumption.

Note that controlled-steer-angle treatments cannot illuminate a bicycle's self stability because, in the small-angle regime, a bicycle with locked steering has no self stability. Many modern studies of controlled stability also reasonably use one or more of the mechanical simplifications like described (i) above.

iii) Mathematically simplified models. To make the mathematics more tractable, or to illuminate controlling factors, some authors eliminate terms from the equations. A possible consequence of such mathematical, as opposed to mechanical, simplifications is that the resulting equations may not describe any particular physical model, so that theorems or intuitions based on mechanics may not apply.

A common geometric issue. Many of these simplified-dynamics analyses include some non-linear terms (e.g., $\sin \phi$ instead of ϕ). However, all purportedly nonlinear simplified-bicycle treatments of which we are aware, starting with Bourlet (1894), do not actually write non-linear equations that correctly describe any mechanically simplified model of a bicycle. That is, the equations are not a special or limiting case of the equations of Whipple and his followers. In these treatments wheel base, trail, frame pitch, path curvature and other such quantities are treated as being independent of the lean angle, even for non-zero steer angle. That these quantities do actually all vary with lean angle for an ideal bicycle is demonstrated by considering a small leftward steer angle. As the lean angle goes to -90 degrees, with the bicycle almost lying on its left side, the front contact point moves forward around the front wheel approximately by 90 degrees, while the rear contact point moves backward around the rear wheel the same amount. This alters the wheel base length, the angle between ground traces of the two wheels, and the trail. Depending on the

frame geometry, this lean also places the front contact well outside the rear frame's symmetry plane, and introduces substantial pitch of the rear frame about the rear axle, relative to the ground trace of the rear wheel. Even the simplest bicycle (with vertical steering axis, zero trail, and vanishing front-wheel radius) is subject to at least an alteration of the front-wheel track direction, due to the lean of a steered wheel. In particular for such a bicycle, the angle ψ that the front wheel track makes with the line connecting rear and front wheel contacts should obey $\cos \phi \tan \psi = \tan \delta$ rather than the commonly used $\psi = \delta$ for (where δ is steer and ϕ is lean).

In some cases the authors may be making conscious approximations that are valid for modest lean angles, in some cases they are making mathematical models that are not intended to literally describe any simplification of a bicycle, and in some cases these seem to be errors. The resulting governing equations are sometimes correct descriptions of an inverted pendulum mounted on a controlled tricycle. Such a tricycle might be considered to be a simple model of a bicycle. But such a tricycle is not any limiting case of the Whipple bicycle.

1894–1899 Mathematician Carlo Bourlet devotes several papers and both editions of his encyclopedic bicycle treatise to the lateral balance of a steer-controlled velocipede (vertical steer axis and no trail). All inertias have vertical principal axes, and spin angular momentum of the wheels is included. The treatment is largely nonlinear, but has the front-contact geometry issues described above. When linearized, his final roll equation (29) *bis* lacks the gyroscopic moment from steer rate, but seems to us to be otherwise correct.

Bourlet considers steering moves that can eliminate a lean, or follow a path. His final and most technical paper on bicycle dynamics (1899) was awarded the Prix Fourneyron (submitted 1897, awarded 1898). Bourlet claims to have outlined the practical design factors leading to self-stability in another book dedicated to the design of bicycles, but he does not address them analytically.

The **Prix Fourneyron** prize is offered biannually by the French Académie des Sciences. In 1897, the Fourneyron mechanics challenge was “Give the theory of movement and discuss more particularly the conditions of stability of velocipedic devices” and was later amplified to include “whether in a straight line or a curve, on a flat plane or a slope.” Boussinesq and Léauté were on the prize committee, and Appell was interested in the entries. Bourlet, Sharp and Carvallo submitted entries, as did others whose names and works are unfamiliar to us. Bourlet won first place, Carvallo shared second with Jacob (whose work we have not found), and Sharp received honourable mention. Both Bourlet and Carvallo published their entries, and Appell prominently cited these and other papers in more than one book. Shortly after the prize was awarded, Boussinesq published his own thorough analysis, and Léauté also published a note. It seems that the dynamical analysis of bicycles is a French innovation. Bourlet (1894) may have started this, then the Prix announcement produced a singular peak of bicycle research activity.

1899 Physicist Joseph Boussinesq wrote two papers (and four prior ‘notes’) on velocipede balance and control. These are similar in approach and content to prior work by Bourlet but slightly anticipating Bourlet’s later more sophisticated dynamical modelling. Boussinesq neglects gyroscopic contributions ex-

pressed as E/R for each wheel, which Bourlet remarks correctly is a minor effect for roll dynamics. Boussinesq also notes that the system's centre of mass can usually be displaced sideways by upper-body lean relative to the frame (This is the means by which an inverted double pendulum can be balanced by actuation of the connecting hinge). Self-stability was not addressed. The simplest point-mass bicycle model (vertical steer axis, no wheel mass, zero-radius wheels, no trail, no mass in the front assembly or equivalently mass balanced with respect to the steer axis, and controlled steer) seems to be due to Boussinesq.

- 1899** G.R.R. Routh (son of famous dynamicist E.J. Routh) considers steering strategies for roll stability and path following of a slightly more general model of a velocipede than was considered by Bourlet (1899) and Boussinesq (1899).
- 1910** Bouasse, in his dynamics textbook, reviews some geometric relations from Bourlet (1899), and presents the model and analysis of Boussinesq (1899).
- 1915** Bower investigates the stability of an uncontrolled velocipede via linearized equations that are missing terms (Hand, 1988). However, Bower's central result, that such a bicycle has no self-stability, happens to be correct. Comparable treatments without fully correct equations are also presented in Pearsall (1922, citing Bower), Lowell & McKell (1982, citing Pearsall), and Fajans (2000, citing Lowell & McKell). Typically, one or several terms are missing from each equation of motion sometimes by intentional neglect of supposedly small contributions. However, one can often find cases where the neglected terms or approximations are significant in effect.
- 1934** Loĭcjanskiĭ & Lur'e, in their textbook, study an uncontrolled velocipede which is cited by Letov (1959), Neĭmark & Fufaev (1967), and revisited in Lobas (1978). We have not seen this book.
- 1948** Timoshenko & Young's well-known dynamics text presents the Boussinesq (simplest) bicycle analysis of Bouasse (1910).
- 1955** Haag independently derives bicycle equations of motion in his book, but simplifies by inconsistently ignoring various terms involving trail, spin momentum, front assembly mass, cross terms in the potential energy, etc. The resulting incorrect differential equations of a simplified bicycle model lead him to conclude (incorrectly) that bicycle self-stability is never possible.
- 1959** Letov gives what seem to be correct linearized roll equation for a Boussinesq bicycle, attributing it to Loĭcjanskiĭ & Lur'e. Gyroscopic torques on the steering due to roll rate are incorporated in the dynamics of the steer controller, with reference to Grammel.
- 1967** Neĭmark & Fufaev, in their classic text on non-holonomic dynamics consider the full Whipple model (see section (c) below). They then simplify to a velocipede model (vertical head, no trail, fore-aft balanced front steering). In the velocipede model the only contribution to self-correcting steer is gyroscopic precession due to lean, the basic mechanism for no-hands but controlled

stability discussed in, e.g., Sharp (1896). However, Neĭmark & Fufaev also include linear viscous friction in the steering column. Without this friction, the steer angle is proportional to the integral of the lean angle. They mistakenly omit the mass from the second term in equation (2.65) (English edition p. 354), leaving a dimensionally incorrect quantity ν to propagate through to equations (2.67) and (2.68). However, the overall form of their differential equations is correct. Even for this simple model they find self-stability if there is sufficiently large steering friction, a result we trust despite the algebra error noted above.

1995 Getz & Marsden consider the possibility of following an arbitrary path without falling over, when not only the steering but also forward speed may be controlled. Their simplified nonlinear Boussinesq model incorporates no wheel radius nor wheel inertias. Like some others before them (e.g. Bourlet 1894) this paper makes geometric assumptions that are equivalent to modelling a bicycle as an inverted pendulum mounted on a tricycle (see discussion above on a “geometric issue”).

2005 One small part of the paper by Åström, Klein & Lennartsson treats a simplified bicycle model. The paper also describes decades of experiments on bicycle stability as well as the development of super-stable bicycles for teaching disabled children to ride (see also Richard Klein’s web page, listed in the bibliography for this paper). Åström *et al.* is also discussed briefly in section (c) below.

The simplified model in Åström *et al.* is aimed at basic explanation of bicycle control and self-stability. We comment here only on the sections relevant to “Self-Stabilization” and not on the paper’s focus, which concerns control.

In Åström *et al.* the reductions leading to the simple model come in two stages, mechanical and then mathematical. First Åström *et al.* assume that the wheels have no spin momentum and are thus essentially skates. They also assume that the front assembly has no mass or inertia. However, both non-zero head angle and non-zero trail are allowed and both point-mass and general-inertia rear-frame mass distributions are considered. Åström *et al.* then add further mathematical simplifications by neglecting non-zero trail contributions except in the static (non-derivative) terms. This eliminates the steer acceleration term in equation (14) therein (roll dynamics), and alters the steer rate term. In equation (9) (steer dynamics), where all torques arise only through trail, this eliminates the terms involving steer rate, steer acceleration, and roll acceleration.

Their reduced 2nd order unforced (uncontrolled) steer equation implies that steer angle is proportional to lean angle (note the contrast with the integral feedback implicit in Neĭmark & Fufaev above). The resulting system is thus stabilized in the same way a skateboard is self-stable. In a skateboard mechanical coupling in the front “truck” enforces steer when there is lean, see Hubbard (1979) and pages 6 and 17 in Papadopoulos (1987). That bicycle lean and steer coupling might approximately reduce to the much simpler skateboard coupling is certainly an attractive idea.

However, the governing stability equation in Åström *et al.*, equation (15) appears to show the emergence of self-stability at high-enough speeds for quite arbitrary bicycle parameters. Examination of the full fourth order equations here (the pair of 2nd order equations) applied to their simplified bicycle (without their additional mathematical simplifications) seems to show that stability is only obtained for special parameters. For example, the point-mass version is never stable. An extended-mass version can be stable, but only with a rather special mass distribution, as discussed in Papadopoulos (1987), on page 6 and figure 3 therein. Even for those parameter values in which their mechanical model can have self-stability it is not clear that the having steer proportional to lean is an appropriate simplification. So we have some doubt about Åström *et al.*'s reduction of even a simple class of bicycle models to 2nd order skateboard-like equations. Limebeer and Sharp (2006) also question Åström *et al.* conclusion about the central role of trail in stability.

2006 Limebeer & Sharp present a large colourful historical review of various issues associated with bicycle and motorcycle handling, including anecdotes, simple models and complex models. One small part of Limebeer & Sharp includes an analysis of a Boussinesq-like simple bicycle. The nonlinear roll equations therein implicitly assume a zero-radius front wheel. Also, in the first roll equation (4) the term $(\sigma - \dot{\phi}/v)$ was mistyped and should be $(\sigma - \dot{\psi}/v)$, which vanishes. Roll equation (5), and its linearization which is used for control analysis, seem fully correct.

(c) *Equations of motion for a Whipple bicycle*

Here we discuss literature on linear equations of motion for more general bicycle models with uncontrolled steering. These are models that are similar to the Whipple model used in this paper. Papers in which e.g. toroidal wheels, tire-slip models, frame or rider elastic deformation, rider steering inputs or rider-controlled torso lean were difficult to remove from the analysis are generally not discussed. Nonlinear treatments are not discussed systematically. The nonlinear literature is further reviewed in Basu-Mandal *et al.* (2006).

1897–1900 Carvalho shared second prize in the Prix Fourneyron (see discussion of Bourlet in section (b) above), for a 186-page monograph on the dynamics of an uncontrolled monocycle (a single wheel surrounding a rider) and bicycle. Carvalho was already an accomplished applied mathematician and mechanic when he submitted this paper in 1897. As far as we know, this is the first genuine analysis of bicycle self-stability and slightly precedes Whipple. Although Carvalho's bicycle is slightly specialized, relative to Whipple, by neglecting the mass and moments of inertia of the front frame (in comparison to those of the front wheel), his equations for his model are correct. Carvalho identified the four standard eigenmodes, and presented equations for the upper (capsize) and lower (weave) limiting velocities for hands-free stability. Carvalho mentions the use of Grassman's geometric calculus, and stability calculations similar to Routh-Hurwitz. According to Carvalho, bicycle constructors of his time recommended that the steer axis be designed to pass under the front

axle, half way between axle and ground, a feature approximately maintained to the present day.

1899 Whipple, apparently unaware of Carvallo, undertakes the second substantive analysis of the self-stability of a bicycle. Whipple was a Cambridge University undergraduate at the time, and was a Second Wrangler in the Tripos mathematics exam. Whipple later had a long career in mathematical meteorology. See Limebeer & Sharp (2006) for a short biography. Whipple's model is equivalent to the model presented here. His paper was awarded Honourable Mention for the prestigious Smith's Prize. Whipple first undertook the difficult task of a fully nonlinear analysis, which was flawed by an incorrect expression of the front-wheel ground-contact vertical constraint. However, when linearized this error is irrelevant, and Whipple's linearized equations are correct, except for a few typographical errors. Whipple's results include scaling rules, the dynamic modes (nowadays known as weave and capsize), rider control inputs via torso lean, etc. Whipple also recognized that the exponential decay of lean and steer perturbations is not inconsistent with energy conservation. He cites Bourlet. Because of ambiguity in submission and publication times, Whipple is sometimes credited as the first to write equations of motion for a complex bicycle model, but it seems to us that Carvallo was actually first. Although Whipple had the same editor as Routh, neither cited the other.

Whipple and Carvallo laid solid foundations for future work. But despite Carvallo being cited in two books by Appell, and both authors being cited by Sommerfeld & Klein (1910), and mentioned both in the 11th edition *Encyclopedia Britannica* (Gyroscope article), and in Grammel's 1920 gyroscope textbook, their achievements languished for decades. The only path by which they seemingly influenced posterity is via Noether (see Sommerfeld & Klein, next in this list) who seems to follow Carvallo. Noether's analysis was expanded to the full Whipple model by Döhring (1953), and in turn was expanded further by Singh & Goel (1971), see below. But no-one ever used Whipple's work, as far as we know.

1910 Klein & Sommerfeld's 4th volume on gyroscopes appears with an extensive chapter on bicycles written by Fritz Noether (brother of mathematician Emmy). These governing equations for a slightly simplified bicycle model (like Carvallo's), derived by Newton-Euler techniques used for other gyroscopic systems, are equivalent to those in Carvallo (1900) and seem fully correct to us. While Noether claims to have compared his equations with Whipple as well as Carvallo, he erroneously states that Whipple used a Lagrangian derivation, and acknowledges neither Whipple's more general model nor his typographical errors. Noether's discussion of gyroscopic contributions and of holonomic and nonholonomic degrees of freedom is clear and informative. Noether is keen to point out (incorrectly we think) that gyroscopic effects are necessary for self-stability, and that steering torques on the trailing front ground contact are not sufficient for stability. In effect Noether introduces, explains and dismisses the trail effects that were later a central interest of David Jones (1970).

- 1948** Kondo in Japan wrote reports on bicycles between 1948 and 1964. In discussion of a paper by Fu, Kondo says he wrote equations of motion for the meeting of JSME in November, 1948, unpublished (we have not seen this). Neither have we checked Kondos later work that included tire models.
- 1949** Herfkens writes a report deriving equations for the Whipple model in Dutch for the Delft Bicycle Institute. The linearized equations of motion are correct, except for some typos. On page 12, Eq. (28), $\cot(\beta)$ should be $\cot(\alpha)$. There is a missing term and misplaced brackets on page 13, and on page 14 the subscript of b_5 is missing in Eq. (34). The coefficients on page 15 agree with ours. Note that his steering angle β is our $\delta \cos(\lambda)$. Using Routh-Hurwitz stability criteria, he looked at the effect of some key parameters (namely trail and front-wheel inertia, and head angle) on the range of self-stability. He knew of Carvallo and Whipple but found them too analytical. Herfkens report never seems to have been copied, distributed or cited.
- 1951** Manning, in a technical report of the British Road Research Laboratory, appears to provide correct nonlinear configuration geometry, and a well-organized derivation of the linearised equations of motion for a full Whipple model. We have not yet checked the equations in detail, but the work shows great care. Manning acknowledges Carvallo's work but that "[Carvallo has] not yet been compared with the results in this note". Manning writes "even if this work is merely a repetition of Carvallo's, it will be valuable to have the theory in a more accessible form, in a more up-to-date notation, and in English." Exactly the sentiment of our present paper (but with respect to Whipple). Ironically Manning's report is stamped "RESTRICTED Not for publication" and seems essentially unknown to the world. It is for sale from his former employer.
- 1953-1955** Döhring, University of Technology Braunschweig, Germany, writes a Ph.D. thesis on the stability of a straight ahead running motorcycle. He builds on the model by Noether (Klein & Sommerfeld, 1910) to make the mass distributions as general as Whipple, whose work he seems not to have used. Döhring misdates Klein and Sommerfeld as 1890, the time when Klein and Sommerfeld started writing their multi-volume book. Döhring's equations seem to agree with ours in detail (Hand, 1988).
- Döhring's are the first perfectly correct equations of the Whipple model presented in the open literature (Whipple had small errors, Carvallo and Klein & Sommerfeld were slightly less general). Döhring also did some eigenvalue stability analysis and did experiments on a motor-scooter and two different motorcycles (1954) to validate his results. Döhring's 1955 paper was translated into English by CALSPAN but this translation is not published.
- Döhring mentions a "turn of the century" bicycle author named Galetti about whom we have no other information.
- 1963-1964** University of Wisconsin dissertations by Collins (1963) and Singh (1964) both involve multi-page equations employing chained parameter definitions. Collins relied on Wallace's (1929) problematic nonlinear geometry, but this should not affect the correctness of his linearization. Although we did not

compare Collins's equations in every detail, we noted a missing term and Psiaki (1979) found computational disagreement. Singh's subsequent conference and journal publications were based on Döhring's (1955) equations (which seem correct), rather than his own.

1966 Ge in Taiwan has a paper with a promising title. And Ge's other publications indicate expertise in rigid-body mechanics. But we have not seen the paper nor succeeded in contacting the person.

1967 Neĭmark & Fufaev, in their authoritative book on non-holonomic dynamics, present an exceptionally clear and thorough derivation of the equations of motion for a Whipple bicycle (we read only the 1972 English translation). Unfortunately, their treatment has several typographical errors, and also has a flaw in the potential energy: equation (2.30) which ignores downward pitch of the frame due to steering. This flaw was later corrected by Dikarev, Dikareva & Fufaev (1981) and independently by Hand (1988).

In 1970 there was a sudden jump in single-track vehicle research, perhaps because of the advent of digital computers and compact instrumentation, increased popularity of large motorcycles (and attendant accidents), and a surge in bicycle popularity. Most authors incorporated tire models which simplifies the equation formulation by avoiding having to implement kinematic constraints. But tire models add empirical parameters and complicate the resulting equations and their interpretation.

1970-1978 CALSPAN. One concentration of single-track research was at CALSPAN (then the Cornell Aeronautical Laboratory), funded by the U.S. government, Schwinn Bicycles and Harley-Davidson. CLASPAN generated about 20 bicycle reports and papers. The CALSPAN program included hand calculations (involving linearized equations and algebraic performance indices for a somewhat simplified model), nonlinear computer models (including high-order rider control inputs), and a comprehensive experimental program (including tire measurements and comparisons to experiments).

CALSPAN reports include: Rice *et al.* (1970), Roland & Massing (1971), Roland & Lynch (1972), Rice & Roland (1972), Lynch & Roland (1972), Miliken (1972), Roland & Rice (1973), Roland & Kunkel (1973) Roland (1973a), Kunkel & Roland (1973), Roland (1973b), Anonymous (1973), Roland (1974), Rice (1974a), Davis & Cassidy (1974), Rice (1974b), Roland & Davis (1974), Rice (1974c), Davis (1975) Kunkel & Rice (1975), Anonymous (1975a), Rice *et al.* (1975), Anonymous (1975b), Kunkel (1975), Kunkel (1976), Rice(?) (1976), Rice & Kunkel (1976), Rice (1978). Six of these reports are singled out below in their chronological places.

1970 Rice & Roland, in a CALSPAN report sponsored by the National Commission on Product Safety, included an appendix on nonlinear equations (except linearized for small steer angles), where compliant, side-slipping tires avoid the need to apply lateral or vertical contact constraints. Rider lean relative to the frame is included. Thus the governing system includes all six velocities of a rigid body, plus the two extra degrees of freedom (steer and rider lean). The tabulated 8×8 first order system is forbiddingly complex, and terms such as

wheel vertical force require a host of subsidiary equations to be defined. This report seems to contain the first use of the term ‘mechanical trail’ to describe the moment arm of the lateral front-contact forces about the steer axis.

- 1971** Roland & Massing, commissioned by the Schwinn bicycle company, write a CALSPAN report on the modelling and experimental validation of an uncontrolled bicycle. The mix of modelling, measuring, and testing is unusually thorough. After correcting an expression for tire slip, then linearizing and imposing constraints their equations agree with the equations here.
- 1971** Robin Sharp (unrelated to Archibald above) considers a model with tire slip, and front-assembly inertia tensor aligned with the steering axis. His partly-nonlinear model treats rear-frame pitch as zero, with a constant force acting upward on the front wheel. When he linearizes and takes the limit of infinite lateral tire stiffness, he introduces minor algebraic and typographical errors (see Hand 1988). This, Sharp’s first of many bicycle and motorcycle dynamics papers, has had a lasting influence. It includes his original naming of the two major eigenmodes as ‘weave’ and ‘capsize’.
- 1971** Singh & Goel use Döhring’s (1955) correct equations and not Singh’s (1964) suspect equations.
- 1972** Roland & Lynch, commissioned by the Schwinn bicycle company, write a CALSPAN report on a rider control model for path tracking, bicycle tire testing, experimental tests to determine the effect of design parameters on the stability and manoeuvrability of the bicycle, and the development of computer graphics for display purposes. For the bicycle model the equations from Roland & Massing (1971) are used.
- 1972** In his Ph.D. thesis Weir explicitly compares his correct equations with the previous slightly incorrect and slightly specialized results of Sharp (1971). Weir appears to be the first to perform such a check. Weir’s thesis is widely cited.
- 1973** Eaton presents governing equations without derivation. He explains that he reconciled his own derivation with (corrected) Sharp (1971) and Weir (1972), although using his own notation and somewhat embellishing the tire models.
- 1973** Roland reports in the open literature, rare for CALSPAN, basically the same equations as in Roland & Massing (1971). Apparently few if any typos were corrected and some further typos seem to have been introduced.
- 1974** Rice at CALSPAN uses simplified linearized analysis to develop steady-state and transient performance indices. He investigates the stiffness matrix (with rider lean included, statically equivalent to a lean moment), which requires only point-mass bicycle parameters. Much of the complication depends on tire parameters. As in Carvallo (1897) and Whipple (1899), formulae are given for capsize speed and for the low speed at which turning leaves the rear frame perfectly upright (when the displacement of the front contact and front centre of mass perfectly balance the roll moment of centrifugal force).

- 1975** Van Zytveld's M.Sc. thesis on a robot bicycle controller develops equations that agree with ours, except for some incorrect terms involving 'rider lean' which drop out for the rigid rider assumption used in our Whipple model. According to van Zytveld, his advisor David Breakwell had developed independently equations of motion, without a rider-robot, that matched van Zytveld when simplified to remove rider lean (see also Breakwell 1982).
- 1975** Singh & Goel elaborate the Whipple model to allow deviations from left-right symmetry and incorporate more sophisticated tire models, leading to a very high order system of governing equations. The derivation appears to follow Sharp (1971) but we have not checked the results in detail.
- 1976** Rice writes a CALSPAN report on simplified dynamic stability analysis. He assumes all inertia tensors to have a vertical principal axis. This report explicitly identifies the frequently-occurring combination of terms which we call S_A .
- 1978** Weir & Zellner present Weir's equations but introduce a sign error in the mistaken belief they are making a correction, and commit several typographical errors (Hand 1988). Weir's thesis (1972), not this paper, should be used for correct equations.
- 1978** Lobas (in translation misspelled into Gobas) extends the treatment by Neimark & Fufaev (1967) to add forward acceleration. When we set acceleration to zero, it appears that the static lean contribution to Lobas's steer equation is in error.
- 1979** Psiaki writes a dense Princeton undergraduate honors thesis on bicycle dynamics. Starting from a fully nonlinear analysis based on Lagrange equations with non-holonomic constraints, he developed linearized equations for both an upright body and for a rigid bent body in hands-free turns. The equations of motion were complex and we have not checked them in detail, but his numerical results match ours to plotting accuracy suggesting, to us, correctness.
- 1981** Dikarev, Dikareva & Fufaev in equation (1.2) therein correct the errors in Neimark & Fufaev (1967). They write subtly about their "refinement" that "Note that in [Neimark and Fufaev] the expression for ϕ was obtained only to within first-order small terms...". This should make their final equations correct, but we have not checked them in detail. This same error was corrected later independently by Hand (1988).
- 1985** Sharp presents a very comprehensive review of extended motorcycle dynamics equations, with an emphasis on capturing weave motions that seem to depend on tire and frame compliance. He has some errors in his description of the pre-1970 literature. Sharp (1985) identifies Sharp (1971) as 'confirmed', with which, but for minor errors, Hand (1988) agrees.
- 1987** Papadopoulos focused on achieving a compact notation and simple derivation of the equations of motion, using Hand's (1988) results as a check. The equations in the present paper are based on this Papadopoulos report.

1988 Hand's Cornell M.Sc. thesis compares a variety of publications and settles on a compact, transparent notation. Hand's thesis was advised by Papadopoulos and nominally by Ruina. Hand shows that several approaches, e.g. (Döhning 1955, Neïmark & Fufaev 1967, Sharp 1971, and Weir 1972) all led to the same governing equations once errors were corrected. Hand, unaware of the work of Dikarev, Dikareva & Fufaev (1981), independently and similarly corrected Neïmark & Fufaev (1967). Nonetheless, Psiaki (2006, personal communication) also checked Hand's derivation which is similar to Neïmark & Fufaev and said Hand's has some missing terms in the Lagrangian that, fortunately, drop out in the linearization.

1988 Mears verified Weir's (1972) thesis and noted Weir's later (1978) errors. Mears also checked against Hand (1988).

The 1980s essentially mark an end to the development of sound equations for the Whipple bicycle model. Equations from Sharp, Weir or Eaton are widely cited as valid, even though explicit comparisons are rare. Subsequent research on motorcycle and bicycle dynamics tends to focus on elaborations necessary for modelling tire and frame deformations or on non-linear modeling.

1990 Franke, Suhr & Rieß derive non-linear equations of a bicycle, with neglect of some dynamic terms. This paper was the topic of an optimistic lead editorial in *Nature* by John Maddox (1990). We did not check the derivation. The authors did not find agreement between integration of their differential equations for small angles and the integration of the Papadopoulos (1987) equations (1990 — private communication). However, recently Lutz Aderhold (2005 — private communication) applied our benchmark bicycle parameters to an updated form of the Franke, Suhr & Rieß non-linear model and obtained agreement of eigenvalues in an approximately upright configuration, within plotting accuracy. Thus we expect that the well-conceived Franke *et al.* model is largely correct, but perhaps for details corrected by Lutz.

2004 Meijaard in preparing for this publication makes an independent derivation of the linearized equations of motion that agrees with the equations here.

2004 Schwab, Meijaard & Papadopoulos write a draft of the present paper and present it at a conference. The present paper subsumes Schwab *et al.* (2004).

2005 Åström, Klein & Lennartsson present a wide-ranging paper, part of which is discussed in section (b) above. Another discussion in the paper builds on Schwab *et al.* (2004) and Papadopoulos (1987) and presents some parameter studies based on them. Åström *et al.* also presents Lennartsson's [1999] simulations from a general purpose rigid-body dynamics code. In addition to some non-linear dynamics observations, they show agreement with the benchmark equations in Schwab *et al.* (2004), although not with enough precision to assure correctness. Recently Lennartsson (2006 — private communication) made a high-precision comparison for the current benchmark parameters, and found agreement out to 12 decimal places.

2006 Meijaard & Schwab extend the Whipple bicycle model with torus wheels and the effects of braking and accelerations caused by moments at the hubs of the rear and front wheel, by a road gradient, and by aerodynamic drag.

2006 Schwab, Meijaard & Kooijman measure dynamic responses on an instrumented bicycle and validate the Whipple model by comparing between the experimentally measured eigenvalues and the eigenvalues predicted by the formulas here. They find good agreement in the speed range for 2 to 6 m/s.

2006 Limebeer & Sharp, in part of a large historical review paper, present the equations of Schwab *et al.* (2004) (the equations that the present publication archives) and also use the AutoSim model of Schwab *et al.* (2004) .

Although many reports, theses, and papers have models at least almost as general as Whipple's model, and many of these are largely correct, as yet there is no consensus that any peer-reviewed paper in English has correct equations.

Supplementary (expanded) bibliography

This bibliography is a superset of the bibliography in the main paper. It includes all of the main paper references and a few dozen more. Length limitations prevented a longer reference list in the main paper, but we wanted more serious researchers to have access to a single comprehensive bibliography, this one.

References

- Anonymous, 1973 Suggested tasks for continuing research in bicycle dynamics, (internal) Calspan Corp., September
- Anonymous, 1975a Discussion of continued bicycle simulation studies Task 1, Calspan Technical Note, June 6
- Anonymous, 1975b Bicycle dynamics suggestions for continuing research. Calspan Corporation, no number. July.
- Appell, P.E. 1896 *Traité de Mécanique Rationnelle*, Vol. II, pp. 297–302, 1st edn. Paris: Gauthier-Villars. Pages 280-285 of the posthumous 6th edition (1953) are nearly identical, though including well-known 19th century references that seem to have been added in the second edition: <http://math-doc.ujf-grenoble.fr/LiNuM/TM/Gallica/S029090.html>
- Appell, P.E. 1899 *Les mouvements de roulement en dynamique*, p. 36. Paris: Gauthier-Villars, <http://gallica.bnf.fr/ark:/12148/bpt6k82007h/f1.item>, <http://gallica.bnf.fr/ark:/12148/bpt6k82007h/f36.item>.
- Åström, K.J., Klein, R.E. & Lennartsson, A. 2005 Bicycle dynamics and control: Adapted bicycles for education and research. *IEEE Control Systems Magazine* **25**(4), 26–47. See also Richard Klein’s web page on his extensive bicycle stability experiments <http://www.losethetrainingwheels.org>
- Basu-Mandal, P., Chatterjee A. and Papadopoulos, J. 2006 Hands-free circular motions of a benchmark bicycle, in preparation for Proc. R. Soc. A.
- Besseling, J. F. 1964 The complete analogy between the matrix equations and the continuous field equations of structural analysis. In *International symposium on analogue and digital techniques applied to aeronautics: Proceedings*, Presses Académiques Européennes, Bruxelles, pp. 223–242.
- Bouasse, H. 1910 *Cours de Mécanique Rationnelle et Expérimentale*, part 2, pp. 620–623. Paris: Ch. Delagrave.
- Bourlet, C. 1894 *Traité des bicycles et bicyclettes suivi d’une application à la construction des vélodromes*, Paris: Gauthier-Villars.
- Bourlet, C. 1898 *Nouveau traité des bicycles et bicyclettes*, Tome I: Équilibre et Direction Paris: Gauthier-Villars.
- Bourlet, C. 1899 *La Bicyclette, sa construction et sa forme*. Paris: Gauthier-Villars.
- Bourlet, C. 1899 Étude théorique sur la bicyclette, *Bulletin de la Société Mathématique de France* **27**, part I pp. 47–67, Part II p. 76–96. Originally submitted in 1897 for the Prix Fourneryon, awarded first place 1898.
- Boussinesq, J. 1899 Aperçu sur la théorie de la bicyclette, *Journal de Mathématiques Pures et Appliquées* **5**, pp. 117–135. Available <http://ruina.tam.cornell.edu/research/> This paper was originally summarized in *Comptes Rendus des Séances de L’Académie des Sciences* Juillet - Decembre 1898 Volume 127 Pages 843–848, 28 November 28: “Relation qui existe, dans la bicyclette roulant sur un sol horizontal, entre le mouvement de progression et le mouvement d’inclinaison” Pages 895-899, December 5 : “Aperçu sur la théorie de la bicyclette: équilibre du cavalier”. Available at <http://ruina.tam.cornell.edu/research/>

- Boussinesq, J. 1899 Complément à une étude récente concernant la théorie de la bicyclette (1): influence, sur l'équilibre, des mouvements latéraux spontanés du cavalier, *Journal de Mathématiques Pures et Appliquées*, **5**, pp. 217–232. Available at <http://ruina.tam.cornell.edu/research/> This paper was originally summarized in *Comptes Rendus des Séances de L'Académie des Sciences* Janvier - Juin 1899. Volume 128 Pages 766–781, March 27 : “De l'effet produit, sur le mouvement d'inclinaison d'une bicyclette en marche, par les déplacements latéraux que s'imprime le cavalier” Pages 859–862, April 4 : “Calcul, dans une hypothèse simple, du déplacement latéral que doit s'imprimer le cavalier, sur une bicyclette en marche, pour porter le centre de gravité du système à une petite distance horizontale voulue de la base de la bicyclette” <http://ruina.tam.cornell.edu/research/>
- Bower, G. S. 1915 Steering and stability of single-track vehicles. *The Automobile Engineer* **V**, 280–283.
- Breakwell, J. V. 1982 (April 12) Riding a bicycle without hands: The stability of a bicycle. Lecture series at Sonoma State University called “What Physicists Do”.
- Carvallo, E. [1897] Théorie du mouvement du monocycle et de la bicyclette Paris :Gauthier-Villars Originally submitted in 1897 for the Prix Fourneyron for which it shared second place in 1898. Published in 1899. Also published as Théorie du mouvement du Monocycle et de la Bicyclette. *Journal de L'École Polytechnique*, Series 2, Part 1, Volume 5, “Cerceau et Monocycle”, 1900, pp. 119–188, 1900. Part 2, Volume 6, “Théorie de la Bicyclette”, pp. 1–118, 1901.
- Collins, R. N. 1963 A mathematical analysis of the stability of two-wheeled vehicles. Ph.D. thesis, Dept. of Mechanical Engineering, University of Wisconsin.
- Cossalter, V. 2002, *Motorcycle Dynamics* (translation of 1999 Italian edition). Race Dynamics, Greendale WI, ISBN: 0972051406
- Cox, A. J. 1998 Angular momentum and motorcycle counter-steering: a discussion and demonstration. *American Journal of Physics* **66**(11), pp. 1018–1019.
- Davis, J. A. & Cassidy, R. J. 1974 The Effect of Frame Properties on Bicycling Efficiency, Calspan Report ZN-5431-V-2, Task Order No. 6 (Schwinn)
- Davis, J. A. 1975 Bicycle tire testing - effects of inflation pressure & low coefficient surfaces, Calspan Report ZN-5431-V-3, Task Order No. 5 (prepared for Schwinn Bicycle Co.) May
- Den Hartog, J. P. 1948 *Mechanics*, article 61. New York and London: McGraw-Hill.
- Dikarev, E.D., Dikareva, S. B., & Fufaev N.A. 1981 Effect of inclination of steering axis and stagger of the front wheel on stability of motion of a bicycle. *Izv. Akad. Nauk. SSSR. Méchanika Tverdogo Tela* **16**(1), pp. 69–73. (Engl. *Mechanics of Solids*, **16**, p. 60)
- Döhring, E. 1953 Über die Stabilität und die Lenkkräfte von Einspurfahrzeugen. Ph.D. thesis, University of Technology Braunschweig, Germany.
- Döhring, E. 1954 Die Stabilität von Einspurfahrzeugen. *Automobil Technische Zeitschrift*, **56**(3),
- Döhring, E. 1955 Die Stabilität von Einspurfahrzeugen. *Forschung Ing.-Wes.* **21**(2), 50–62. (Transl. by J. Lotsof, *Stability of single-track vehicles*, March 1957) (available at <http://ruina.tam.cornell.edu/research/>)
- Eaton, D. J. 1973 Man-machine dynamics in the stabilization of single-track vehicles. Ph.D. thesis, University of Michigan. <http://ruina.tam.cornell.edu/research/>
- Fajans, J 2000 Steering in bicycles and motorcycles, *Am. J. Phys.* **68**(7), July, 654–659
- Foale, T. 2006 *Motorcycle Handling and Chassis Design: The Art and Science*, Edition 2, Published by Tony Foale ISBN: 8493328634
- Franke, G., Suhr, W. & Rieß, F. 1990 An advanced model of bicycle dynamics. *Eur. J. Physics.* **11**(2), 116–121.

- Ge, Zheng-Ming 1966 Kinematical and Dynamic Studies of a Bicycle, Publishing House of Shanghai Chiao Tung University. <http://wwwdata.me.nctu.edu.tw/dynamic/chaos.htm> (click on director)
- Getz, N. H. & Marsden, J. E. 1995 Control for an autonomous bicycle. In *IEEE Conference on Robotics and Automation. 21-27 May 1995, Nagoya, Japan*.
- Grammel, R. 1920 *Der Kreisel*, ch. 15, pp. 183–186. Braunschweig: Vieweg & Sohn.
- Grammel, R. 1950 *Der Kreisel*, Vol 2, ch. 3, pp. 53–57. Berlin: Springer Verlag.
- Guo, Y. 1984 The equations of bicycling motion (Chinese); Journal of Beijing Institute of Light Industry, v2, n1, April, pp97–104.
- Haag, J. 1955 Oscillatory motions (Volume 2), Presses Universitaires de France, translation published by Wadsworth Publishing Company, Belmont CA.
- Hand, R. S. 1988 Comparisons and stability analysis of linearized equations of motion for a basic bicycle model. M.Sc. thesis, Cornell University. (available at <http://ruina.tam.cornell.edu/research/>)
- Herfkens, B. D. 1949 De stabiliteit van het rijwiel, (In dutch, The stability of the bicycle.) Report S-98-247-50-10-'49, Instituut voor rijwielontwikkeling, Delft, The Netherlands. (available at our website.)
- Herlihy, D. V. 2004 *Bicycle: The history*, New Haven, CT: Yale University Press.
- Higbie, J. 1974 The motorcycle as a gyroscope, *American Journal of Physics* **42**(8), pp. 701–702.
- Hubbard, M. 1979 Lateral dynamics and stability of the skateboard. *Journal of Applied Mechanics*, 46:931–936.
- Jones, A. T. 1942 Physics and Bicycles, *American Journal of Physics*, **10**(6), pp. 332–333.
- Jones, D. E. H. 1970 The Stability of the bicycle. *Physics Today* **23**(3), 34–40. Re-issued September 2006, **59**, 9, pp. 51–56
- Jonker, J. B. 1988 A finite element dynamic analysis of flexible spatial mechanisms and manipulators. Ph.D. thesis, Delft University of Technology, Delft.
- Jonker, J. B. & Meijaard, J. P. 1990 SPACAR—Computer program for dynamic analysis of flexible spatial mechanisms and manipulators. In *Multibody Systems Handbook* (ed. W. Schiehlen). Berlin: Springer-Verlag, pp. 123–143.
- Kane, T. R. 1968 *Dynamics*. New York: Holt, Rinehart and Winston.
- Kane, T. R. 1975 Fundamental kinematic relationships for single-track vehicles. *International Journal of Mechanical Sciences* **17**, 499–504.
- Kane, T. R. 1977 Steady turning of single-track vehicles, Paper 770057 Society of Automotive Engineers, International Automotive Engineering Congress and Exposition, Detroit
- Kirshner, D. 1980 Some nonexplanations of bicycle stability. *American Journal of Physics*, **48**(1), pp. 36–38.
- Klein, F. & Sommerfeld, A. 1910 *Über die Theorie des Kreisels*, Ch. IX, Section 8, Stabilität des Fahrrads, by F. Noether, pp. 863–884. Leipzig: Teubner. (English translation available at <http://ruina.tam.cornell.edu/research/>)
- Koenen, C. 1983 The dynamic behaviour of a motorcycle when running straight ahead and when cornering. Ph.D. thesis, Delft University of Technology, Delft.
- M. Kondo, Experimental study on the stability and control of single-track vehicles, Proc. Japan Soc. Mech. Eng., vol. 58, pp. 827833, 1955.
- Kondo, M. 1962 Dynamics of single-track vehicles. Foundation Bicycle Tech. Research.
- Kondo, M., Nagaoka, A., and Yoshimura, F. 1963 Theoretical study on the running stability of the two-wheelers. *Trans S.A.E. Japan* **17**(1), pp. 8–18.
- Kooijman, J. D. G. 2006 Experimental validation of a model for the motion of an uncontrolled bicycle, M.Sc. thesis, Delft University of Technology.

- Kunkel, D. T. & Roland, R. D. 1973 A comparative evaluation of the Schwinn Continental and Continental-based Sprint bicycles, Calspan Report ZN-5361-K, August
- Kunkel, D. T., & Rice, R. S. 1975 Low speed wobble study of the Harley Davidson Electra Glide FLH-1200 motorcycle, Calspan Report ZN-5473-V-1, July
- Kunkel, D. T. 1975 Simulation Study of Motorcycle Response to Pavement Grooving, Calspan Report ZN-5740=V-1, for Texas A&M University.
- Kunkel, D. T. 1976 Bicycle dynamics - simulated bicycle / rider system performance in a turning maneuver, Calspan Report ZN-5921-V-1, Task Order No. 7, (prepared for Schwinn Bicycle Co.) July
- Lallement, P. 1866 Improvement in velocipedes, U.S. Patent 59915.
- Lennartsson, A. 1999 Efficient multibody dynamics, Ph.D. thesis, Royal Institute of Technology, Stockholm.
- Le Hénaff, Y. 1987 Dynamical stability of the bicycle, *Eur. J. Phys.*, **8**(3), pp. 207–210.
- Letov (1959), A.M. "Stability of an automatically controlled bicycle moving on a horizontal plane," *Appl. Math. Mechanics*, vol. 23, no. 4, pp. 650–655. Translation pages 934–942
- Limebeer, D. J. N. & Sharp, R. S., 2006. Bicycles, Motorcycles and Models, *IEEE Control Systems Magazine*, **26**(5), pp. 34–61.
- Lobas, L. G. 1978 Controlled and programmed motion of a bicycle on a plane. *Mechanics of solids* **13**(6), 18. (Transl. by Allerton Press [author's name misspelled "Gobas"], Cited in translation as *Izv. AN SSSR. "Mekhanika Tverdogo Tela,"* Vol. 13, No. 6, pp. 22–28, 1978.)
- Loicjanskii (or Loitsyanskii), L. G. & Lur'e (or Lurie), A. I. 1934 *Course of Theoretical Mechanics*, Vol. 3, ONTI, Moscow, 1934; Vol. 2, 5th edn., GITTL, Moscow, 1955.
- Lowell, J. & McKell, H. D. 1982 The stability of bicycles. *American Journal of Physics* **50**(12), 1106–1112.
- Lynch, J. P. & Roland, R. D. 1972 Computer Animation of a Bicycle Simulation, Fall Joint Computer Conference (clipping from journal or magazine).
- Maddox, J. 1990 Bicycling about to be explained? *Nature* **346** 2 Aug 1990, pp. 407.
- Manning, J. R. 1951 The dynamical stability of bicycles, Report RN/1605/JRM, Department of Scientific and Industrial Research, Road Research Laboratory, Crowthorne, Berkshire, UK.
- Maunsell, F. G. 1946 Why does a bicycle keep upright? *The Mathematical Gazette* **30**(291), pp. 195–199.
- Mears, B. C. 1988 Open loop aspects of two wheeled vehicle stability characteristics. Ph.D. thesis, University of Illinois at Urbana–Champaign, IL.
- Meijaard, J. P. 1991 Direct determination of periodic solutions of the dynamical equations of flexible mechanisms and manipulators. *International Journal for Numerical Methods in Engineering* **32**, 1691–1710.
- Meijaard, J. P. 2004 Derivation of the linearized equations for an uncontrolled bicycle. Internal report University of Nottingham, UK.
- Meijaard, J. P. & Schwab, A. L. 2006 Linearized Equations for an Extended Bicycle Model, C.A. Mota Soares et al. eds. *III European Conference on Computational Mechanics Solids, Structures and Coupled Problems in Engineering*, 18 pp., Lisbon, Portugal, 5–9 June 2006.
- Milliken, D. L. 1972 A Supplement to an Evaluation of the Safety Performance of Tricycles and Minibikes
- Neimark, Ju. I. & Fufaev, N. A. 1972 *Dynamics of Nonholonomic Systems*. Providence, RI: A.M.S. (Transl. from the Russian edition, Nauka, Moscow, 1967.)
- Olsen, J. & Papadopoulos, J.M. 1988a Bicycle Dynamics - The Meaning Behind the Math. *Bike Tech*, Dec, pp. 13–15.

- Olsen, J. & Papadopoulos, J.M. 1988b Unpublished supplementary material for Olsen and Papadopoulos (1988a) is available at <http://ruina.tam.cornell.edu/research/>
- Papadopoulos, J. M. 1987 Bicycle steering dynamics and self-stability: A summary report on work in progress. Technical report, Cornell Bicycle Research Project, Cornell University, pp. 1–23.
(available with other related reports at: <http://ruina.tam.cornell.edu/research/>).
- Patterson, B. 1993 *The Lords of the Chainring*, published by Patterson, 3058 Lancaster Dr., Santa Maria, California, U.S.A.
- Pearsall, R. H. 1922 The stability of a bicycle. *The Institution of Automobile Engineers*, Proceeding Session 1922–23 Part I, Vol. XVII, pp. 395–404.
- Psiaki, M. L. 1979 Bicycle stability: A mathematical and numerical analysis. Undergraduate thesis, Physics Dept., Princeton University, NJ.
- Rankine, W. J. M. 1869 On the dynamical principles of the motion of velocipedes. *The Engineer* **28**, pp. 79, 129, 153, 175, **29**(1870), pp. 2. <http://tam.cornell.edu/als93/>
- Rice, R. S. & Roland, R.D. 1970 An evaluation of the performance and handling qualities of bicycles. Calspan Report VJ-2888-K (prepared for National Commission on Product Safety). April
- Rice, R. S. & Roland, R.D. 1972 An evaluation of the safety performance of tricycles and minibikes, Calspan Report ZN-5144-K-1, (Prepared for the Department of Health, Education, and Welfare) November
- Rice, R. S. 1974a, A Note on Design Criteria for Bicycle Stability in terms of Front End Geometry, Calspan internal memo.
- Rice, R. S. 1974b Comparison of bicycle designs using stability index values, Letter to Schwinn Bicycle Co. from Calspan Corp., March 19
- Rice, R.S. 1974c Bicycle dynamics simplified steady state response characteristics and stability indices, Calspan Report ZN-5431-V-1, Task Order No. 2, (prepared for Schwinn Bicycle Co.) June
- Rice, R.S., Davis, J. A. & Kunkel, D. T. 1975 Accident avoidance capabilities of motorcycles, Calspan Report No. ZN-5571-V-1 and V-2, July
- Rice, R. S. 1976 Bicycle dynamics - simplified dynamic stability analysis, Calspan Report ZN-5921-V-2, Task Order No. 8. (prepared for Schwinn Bicycle Co.) September
- Rice, R. S. & Kunkel, D. T. 1976 Accident Avoidance Capabilities of Motorcycles - Lane Change Maneuver Simulation and Full-Scale Tests, Calspan Report ZN-5899-V-1, DOT, NHTSA sponsorship.
- Rice, R. S. 1978 Rider skill influences on motorcycle maneuvering. SAE paper 780312, SAE-SP 428
- Roland, R. D. & Massing, D. E. 1971 A digital computer simulation of bicycle dynamics. Cornell Aero. Lab. Report no. YA-3063-K-1. June (prepared for the Schwinn Co.)
- Roland, R. D. & Lynch, J. P. 1972 Bicycle dynamics tire characteristics and rider modeling. Cornell Aero. Lab. Report no. YA-3063-K-2. March (prepared for the Schwinn Co.)
- Roland, R. D. & Rice, R. S. 1973 Bicycle dynamics, rider guidance modeling and disturbance response. Calspan Report ZS-5157-K-1, April
- Roland, R. D. & Kunkel, D. T. 1973 Motorcycle dynamics, the effects of design on high speed weave, Calspan Report ZN-5259-K-1 (prepared for Harley-Davidson Motor Company), May
- Roland, R. D. 1973a Simulation study of motorcycle stability at high speed, SAE paper 73020, Proc. Second International Congress on Automotive Safety, July 16-18, San Francisco.
- Roland, R. D. 1973b Computer simulation of bicycle dynamics, *Mechanics and Sport* **4**, ed J. L. Bleustein, American Society of Mechanical Engineers, New York

- Roland, R. D. 1974 Performance Tests of Harley-Davidson Electra Glide FLH-1200 Motorcycle Tires, Calspan Report ZN-5438-V-1 (for Harley-Davidson).
- Roland, R. D. & Davis, J. A. 1974 (internal) Progress report research in bicycle dynamics, May 9
- Routh, G. R. R. 1899 On the Motion of a Bicycle. *The Messenger of Mathematics* **28**, pp. 151–169. <http://ruina.tam.cornell.edu/research/>
- Ruina, A. 1998 Non-holonomic stability aspects of piecewise holonomic systems. *Reports on Mathematical Physics*, **42**(1/2), pp. 91–100.
- SAE (Society of Automotive Engineers) 2001 Vehicle dynamics Terminology—SAE J670e. *2001 SAE Handbook*, SAE international, Warrendale, PA.
- Sayers, M. W. 1991a Symbolic computer language for multibody systems. *Journal of Guidance, Control, and Dynamics* **14**, 1153–1163.
- Sayers, M. W. 1991b Symbolic vector/dyadic multibody formalism for tree-topology systems. *Journal of Guidance, Control, and Dynamics* **14**, 1240–1250.
- Schwab, A. L. 2002 Dynamics of flexible multibody systems. Ph.D. thesis, Delft University of Technology, Delft.
- Schwab, A. L. & Meijaard, J. P. 1999 Dynamics of flexible multibody systems having rolling contact: Application of the wheel element to the dynamics of road vehicles. *Vehicle System Dynamics Supplement* **33**, 338–349.
- Schwab, A. L. & Meijaard, J. P. 2003 Dynamics of flexible multibody systems with non-holonomic constraints: A finite element approach. *Multibody System Dynamics* **10**, 107–123.
- Schwab, A. L. , Meijaard, J. P. & Kooijman, J. D. G. 2006 Experimental validation of a model of an uncontrolled bicycle, C.A. Mota Soares et al. eds. *III European Conference on Computational Mechanics Solids, Structures and Coupled Problems in Engineering*, 16 pp., Lisbon, Portugal, 5–9 June 2006.
- Schwab, A. L., Meijaard, J. P. & Papadopoulos, J. M. 2005 Benchmark results on the linearized equations of motion of an uncontrolled bicycle. *KSME International Journal of Mechanical Science and Technology* **19**(1), 292–304.
- Seffen, K.A. 1999 Bicycle-Rider Dynamics; Equations of Motion and Controllability, Joint technical report: UMIST/ME/AM/15.07.99/CUED; Cambridge University Engineering Department CUED/C-EDC/TR 79.
- Seffen, K.A., Parks, G.T. and Clarkson P.J. 2001 Observations on the controllability of motion of two-wheelers, *Proceedings of the Institution of Mechanical Engineers, Part I Systems and Control Engineering* **215**(12), pp. 143–156.
- Sharp, A. 1896 *Bicycles and tricycles; an elementary treatise on their design and construction*, London: Longmans Green.
- Sharp, R. S. 1971 The stability and control of motorcycles. *Journal of Mechanical Engineering Science* **13**(5), 316–329.
- Sharp, R. S. 1985 The lateral dynamics of motorcycles and bicycles. *Vehicle System Dynamics* **14**, 265–283.
- Singh, D. V. 1964 Advanced concepts of the stability of two-wheeled vehicle- application of mathematical analysis to actual vehicles. Ph.D. Thesis, Dept. of Mechanical Engineering, University of Wisconsin.
- Singh, D. V. & Goel, V. K. 1971 Stability of Rajdoot Scooter. *SAE Paper no. 710273*.
- Singh, D. V. & Goel, V. K. 1975 Stability of single track vehicles. In *Proceedings of IUTAM Symposium, The Dynamics of vehicles on roads and on railway tracks, Delft, the Netherlands, Aug 18–22, 1975*, pp. 187–196.
- Steele Jr, G. L. 1990 *Common Lisp, The Language*, 2nd edn., Digital Press, U.S.A.
- Timoshenko, S. & Young, D. H. 1948 *Advanced Dynamics*. New York: McGraw-Hill.

- Van der Werff, K. 1977 Kinematic and dynamic analysis of mechanisms, a finite element approach. Ph.D. thesis, Delft University of Technology, Delft.
- Van Zytveld, P. J. 1975 A method for the automatic stabilization of an unmanned bicycle. M.Sc. thesis, Dept. of Aeronautics and Astronautics, Stanford University, CA. (available at <http://ruina.tam.cornell.edu/research>.) See equivalently a report with the same title and date, with a cover from the Stanford University Center for Systems Research, Guidance and Control Laboratory
- Wallace, J. 1929 The super-sports motor cycle (with an appendix on steering layout). *Institution of Automobile Engineers*, Proceedings **24**, , November, pp. 161–217
- Weir, D. H. 1972 Motorcycle handling dynamics and rider control and the effect of design configuration on response and performance. Ph.D. thesis, University of California, LA.
- Weir, D. H. & Zellner, J. W. 1978 Lateral-directional motorcycle dynamics and rider control. Technical report no. 780304, Society of Automotive Engineers, Warrendale, PA.
- Whipple, F. J. W. 1899 The Stability of the Motion of a Bicycle. *The Quarterly Journal of Pure and Applied Mathematics* **30**, 312–348.
- Wilson, D. G. 2004 *Bicycling science*, 3rd edn. with contributions by Jim Papadopoulos. Cambridge, MA: MIT Press.

2. SPACAR model

The SPACAR model for the benchmark bicycle is sketched in figure 5 and the input file for the SPACAR program describing this model is presented in §2 a.

Because the SPACAR program is based on finite-element methods (FEM), the input file shows an FEM structure. SPACAR is designed to minimize the information needed in the input file. The SPACAR input file is roughly divided into four parts: element declaration and connectivity, nodal data, boundary conditions, and some additional data like masses, inertias, applied forces and simulation settings.

In the first section of input in §2 a the elements are declared, they are given a type, a unique element number followed by a list of node numbers and an initial rotation axis. These element statements implicitly define the associated nodes. The nodes are either translational or rotational. A **hinge** element allows large relative rotation between two rotational nodes. A **wheel** element allows rolling contact at the contact point node. A **pinbody** element generates a node within a rigid body by which another finite element can be connected. Within this finite element approach a rigid body can be defined in two ways: either as a deformable element with all deformation modes set to zero or as a body with one three-degree-of-freedom translational node and one three-degree-of-freedom rotational node.

In the second section of the input file the nodes, which are placed at the centre of mass of the rigid bodies, are given their reference-configuration coordinates. Translational nodes have three coordinates (x, y, z) in a global reference frame whereas rotational nodes are parameterized by four Euler parameters. These parameters are set to $(1, 0, 0, 0)$, the unit transformation, in the reference configuration.

The approach in establishing a bicycle model is to consider it in a reference configuration: upright, orientated along the x-axis, and with the rear contact at the origin. This configuration is used to define nodal positions and rigid body orientations. Relative to this reference configuration it is easy to set an initial lean or steer angle and set the rates as initial conditions. To do a simulation from an arbitrary configuration, however, you have to drive it there by specifying a path from the initial configuration to the desired initial state.

Any consistent set of units may be used. Here SI units are used.

In the third section the boundary conditions are set, the implicit definition is that all nodes are free and all elements are rigid. A node's position or orientation in space can be fixed by the **fix** command; otherwise it is free to move in space. An element can be allowed to "deform" e.g. a hinge element is allowed to rotate, by the **rlse** command. A non-zero prescribed "deformation" mode is specified by **inpute**, e.g. the forward motion of the bicycle in this example. For generating linearized equations of motion the **line** command identifies a degree of freedom to be used. The **enhc** command ties a nonholonomic constraint to a configuration space coordinate so as to identify those configuration coordinates for which the time derivative is not a velocity degree of freedom.

In the last section mass and inertia are added to the nodes, one value for translational nodes and six values for rotational nodes (the terms in the upper triangle portion of the inertia matrix in the initial configuration). Finally applied (constant) forces are added and some initial conditions and simulation settings are made.

When the program is run, for each output time step, all system variables (coordinates, deformations, speeds, accelerations, nodal forces, element forces, etc.) are

written to standard files which can later be read by other software for plotting or analysis. At every time step the numeric values of the coefficients of the SPACAR semi-analytic linearization are also written to standard files.

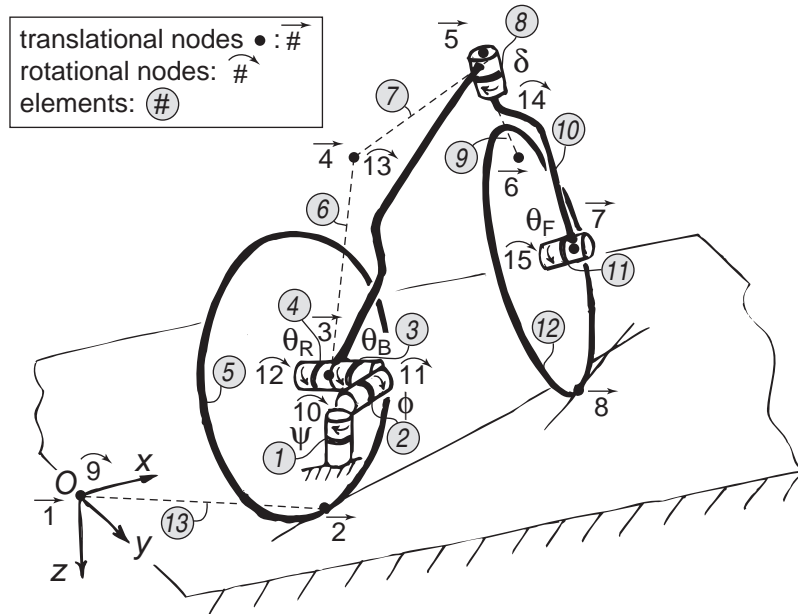

Figure 5. Sketch of the bicycle model for SPACAR input together with node numbers (straight arrows for translations 1...8, curved arrows for rotations 9...15) and element numbers encircled.

(a) SPACAR Input file

The sketch of this model is shown in figure 5.

```
% SPACAR input file for bicycle benchmark I
% SECTION 1, ELEMENT DECLARATION AND CONNECTIVITY:
% type number nodes      rotation axis vector
hinge 1 9 10             0 0 1 % yaw angle rear frame between node 9(ground) and 10
hinge 2 10 11            1 0 0 % lean angle rear frame between node 10 and 11
hinge 3 11 13            0 1 0 % pitch angle rear frame between node 11 and 13(frame)
hinge 4 13 12            0 1 0 % rear wheel rotation between 13(frame) and 12(wheel)
wheel 5 3 12 2           0 1 0 % rear wheel, cm nodes 3, 12, contact pnt 2
pinbody 6 4 13 3         % node 3(rear hub) in rigid body nodes 4, 13(frame)
pinbody 7 4 13 5         % node 5(head) in rigid body nodes 4, 13(frame)
hinge 8 13 14            0.32491969623291 0 1.0 % steering angle between 13 and 14
pinbody 9 5 14 6         % node 6(cm fork) in rigid body 5, 14(front frame)
pinbody 10 5 14 7        % node 7(front hub) in rigid body 5, 14(front frame)
hinge 11 14 15           0 1 0 % front wheel rotation between 14 and 15(wheel)
wheel 12 7 15 8          0 1 0 % front wheel, cm nodes 7, 15, contact pnt 8
pinbody 13 1 9 2         % node 2(rear contact pnt) in rigid body nodes 1, 9
% SECTION 2, NODAL DATA:
% node initial coordinates,      all rotational nodes are initialized:(1,0,0,0)
```

```

x  1  0  0  0  % fixed origin
x  2  0  0  0  % rear contact point
x  3  0  0 -0.3 % rear hub
x  4  0.3 0 -0.9 % cm rear frame + rigid rider
x  5  0.80757227339038 0 -0.9 % steering head
x  6  0.9 0 -0.7 % cm front fork + handle bars
x  7  1.02 0 -0.35 % front hub
x  8  1.02 0 0 % front contact point
% SECTION 3, BOUNDARY CONDITIONS:
% type number components
fix  1  1  2  3  % fix all(1,2,3) translations node 1(ground)
fix  9  1  2  3  4 % fix all(1,2,3,4) rotations node 9(ground)
rlse  1  1  % release rotation(1) hinge 1: yaw
rlse  3  1  % release rotation(1) hinge 3: pitch
rlse  11  1  % release rotation(1) hinge 11: front wheel rotation
rlse  13  1  2  3 % release all relative displacements(1,2,3) in pinbody 13
inpute  4  1  % rotation(1) hinge 4 is prescribed motion for forward speed
line  2  1  % generate linearized eqns for rotation(1) hinge 2: lean
line  8  1  % generate linearized eqns for rotation(1) hinge 8: steering
% tie a non-holonomic constraint to a configuration space coordinate
%type lmnt mode lmnt mode (lmnt means element number)
enhc  5  4  13  1 % wheel 5 4=long slip tied to pinbody 13 1=x-disp node 2
enhc  5  5  13  2 % wheel 5 5=lat slip tied to pinbody 13 2=y-disp node 2
enhc  12  4  1  1 % wheel 12 4=long slip tied to hinge 1 1=yaw rear frame
enhc  12  5  11  1 % wheel 12 5=lat slip tied to hinge 11 1=front wheel rot
% SECTION 4, ADDITIONAL DATA: MASS, INERTIA, APPLIED FORCES, AND SIMULATION SETTINGS
% node mass:(m) or mass moment of inertia:(Ixx,Ixy,Ixz,Iyy,Iyz,Izz)
mass  3  2.0 % mass rear wheel
mass  12  0.0603 0 0 0.12 0 0.0603 % inertia rear wheel
mass  4  85.0 % mass rear frame + rider
mass  13  9.2 0 2.4 11.0 0 2.8 % inertia rear frame + rider
mass  6  4.0 % mass front frame + handle bars
mass  14  0.05892 0 -0.00756 0.06 0 0.00708 % inertia front frame + handle bars
mass  7  3.0 % mass front wheel
mass  15  0.1405 0 0 0.28 0 0.1405 % inertia front wheel
% node applied force vector (gravity used g = 9.81)
force  3  0 0 19.62 % gravity force rear wheel
force  4  0 0 833.85 % gravity force rear frame + rider
force  6  0 0 39.24 % gravity force front frame + handle bars
force  7  0 0 29.43 % gravity force front wheel
% initial conditions
ed  4  1 -3.333333333 % angular velocity in hinge 4(forward speed) set to -3.333333333
% simulation settings
epskin 1e-6 % set max constraint error for Newton-Raphson iteration
epsint 1e-5 % set max numerical integration error on coordinates
epsind 1e-5 % set max numerical integration error on speeds
timestep 100 2.0 % set number of output timesteps and simulation time
hmax 0.01 % set max step size numerical integration
end % end of run
eof % end of file

```

3. AutoSim model

The AutoSim input file used for the bicycle model is listed below. The generalized coordinates and velocities are the same as those in the SPACAR model. Two massless intermediate reference frames have been introduced: a yawing frame describing the horizontal translation and yawing of the rear frame and a rolling frame describing the lean of the rear frame with respect to the yawing frame. These additional frames allow a better control over the choice of the generalized coordinates by the program. The holonomic constraint at the rear wheel is automatically satisfied. The holonomic constraint at the front wheel and the four non-holonomic constraints are explicitly defined in the input file. For more details on the syntax used see the AutoSim documentation.

(a) *AutoSim Input file*

```

;;; This is the file fietsap2.lsp, with the benchmark1 model.
;; Set up preliminaries:
(reset)
(si)
(add-gravity :direction [nz] :gees g)
(set-names g "Acceleration of gravity" )
(set-defaults g 9.81) ; this value is used in the benchmark.
;; The name of the model is set to the string "fiets".
(setsym *multibody-system-name* "fiets")
;; Introduce a massless moving reference frame. This frame has x and y
;; translational degrees of freedoms and a yaw rotational degree of freedom.
( add-body yawframe :name "moving yawing reference frame"
  :parent n :translate (x y) :body-rotation-axes z
  :parent-rotation-axis z :reference-axis x :mass 0
  :inertia-matrix 0 )
;; Introduce another massless moving reference frame. This frame has a rolling
;; (rotational about a longitudinal axis) degree of freedom.
( add-body rollframe :name "moving rolling reference frame" :parent yawframe
  :body-rotation-axes (x) :parent-rotation-axis x :reference-axis y :mass 0
  :inertia-matrix 0 )
;; Add the rear frame of the bicycle. The rear frame has a pitching (rotation
;; about the local lateral y-axis of the frame) degree of freedom.
( add-body rear :name "rear frame" :parent rollframe
  :joint-coordinates (0 0 "-Rrw") :body-rotation-axes y
  :parent-rotation-axis y :reference-axis z :cm-coordinates (bb 0 "Rrw-hh")
  :mass Mr :inertia-matrix ((Irxx 0 Irxz) (0 Iryy 0) (Irxz 0 Irzz)) )
( set-names
  Rrw "Rear wheel radius"
  bb "Longitudinal distance to the c.o.m. of the rear frame"
  hh "Height of the centre of mass of the rear frame"
  Mr "Mass of the rear frame"
  Irxx "Longitudinal moment of inertia of the rear frame"
  Irxz "Minus product of inertia of the rear frame"
  Iryy "Transversal moment of inertia of the rear frame"
  Irzz "Vertical moment of inertia of the rear frame" )
( set-defaults Rrw 0.30 bb 0.3 hh 0.9
  Mr 85.0 Irxx 9.2 Irxz 2.4 Iryy 11.0 Irzz 2.8 )

```

```

;; Add the rear wheel of the vehicle. This body rotates
;; about the y axis of its physical parent, the rear frame.
( add-body rw :name "rear wheel" :parent rear :body-rotation-axes y
  :parent-rotation-axis y :reference-axis z :joint-coordinates (0 0 0)
  :mass Mrw :inertia-matrix (irwx irwy irwx) )
( set-names
  Mrw "mass of the rear wheel"
  irwx "rear wheel in-plane moment of inertia"
  irwy "rear wheel axial moment of inertia" )
(set-defaults Mrw 2.0 irwx 0.0603 irwy 0.12)
;; Now we proceed with the front frame.
;; Define the steering and reference axes of the front frame.
;; Add in the front frame: define some points.
( add-point head :name "steering head point B" :body n
  :coordinates (xcohead 0 zcohead) )
( add-point frontcmpoint :name "c.o.m. of the front frame" :body n
  :coordinates (xfcm 0 zfcm) )
( set-names
  epsilon "steering head angle"
  xcohead "x coordinate of the steering head point B"
  zcohead "z coordinate of the steering head point B"
  xfcm "x coordinate of the c.o.m. of the front frame"
  zfcm "z coordinate of the c.o.m. of the front frame" )
( set-defaults epsilon 0.314159265358979316
  xcohead 1.10 zcohead 0.0 xfcm 0.90 zfcm -0.70 )
( add-body front :name "front frame" :parent rear :body-rotation-axes z
  :parent-rotation-axis "sin(epsilon)*[rearx]+cos(epsilon)*[rearz]"
  :reference-axis "cos(epsilon)*[rearx]-sin(epsilon)*[rearz]"
  :joint-coordinates head :cm-coordinates frontcmpoint :mass Mf
  :inertia-matrix ((Ifxx 0 Ifxz) (0 Ifyy 0) (Ifxz 0 Ifzz))
  :inertia-matrix-coordinate-system n )
( set-names
  Mf "Mass of the front frame assembly"
  Ifxx "Longitudinal moment of inertia of the front frame"
  Ifxz "Minus product of inertia of the front frame"
  Ifyy "Transversal moment of inertia of the front frame"
  Ifzz "Vertical moment of inertia of the front frame" )
( set-defaults Mf 4.0
  Ifxx 0.05892 Ifxz -0.00756 Ifyy 0.06 Ifzz 0.00708 )
;; Add in the front wheel:
( add-point fw_centre :name "Front wheel centre point" :body n
  :coordinates (ll 0 "-Rfw") )
( add-body fw :name "front wheel" :parent front :body-rotation-axes y
  :parent-rotation-axis y :reference-axis "[nz]"
  :joint-coordinates fw_centre :mass Mfw :inertia-matrix (ifwx ifwy ifwx) )
( set-names
  ll "Wheel base"
  Rfw "Radius of the front wheel"
  Mfw "Mass of the front wheel"
  ifwx "In-plane moment of inertia of the front wheel"
  ifwy "Axial moment of inertia of the front wheel" )
(set-defaults ll 1.02 Rfw 0.35 Mfw 3.0 ifwx 0.1405 ifwy 0.28)

```

```

;; The system is complete, except for the contact constraints at the wheels.
;; The holonomic constraint at the rear wheel is automatically satisfied.
;; The rear wheel slip is zero.
( add-speed-constraint "dot(vel(yawframe0),[yawframex])+Rrw*(ru(rear)+ru(rw))"
  :u "tu(yawframe,1)" )
(add-speed-constraint "dot(vel(yawframe0),[yawframey])" :u "tu(yawframe,2)")
;; For the front wheel we have a holonomic constraint for the contact and two
;; non-holonomic slip constraints. The slip velocities are defined now.
(setsym singammafw "dot([fwy],[nz])")
(setsym cosgammafw "sqrt(1-@singammafw**2)")
(setsym fw_rad "([nz] - [fwy]*@singammafw)/@cosgammafw")
(setsym slipfw_long "dot(vel(fw0)+Rfw*cross(rot(fw),@fw_rad),[nx])")
;; No longitudinal slip on front wheel;
;; eliminate rotational velocity about the axis
(add-speed-constraint "@slipfw_long" :u "ru(fw)")
;; normal constraint; eliminate the pitch angle
(setsym slipfw_n "dot(vel(fw0)+Rfw*cross(rot(fw),@fw_rad),[nz])")
(add-speed-constraint "@slipfw_n" :u "ru(rear)")
(add-position-constraint "dot(pos(fw0),[nz])+Rfw*@cosgammafw" :q "rq(rear)")
;; No lateral slip on front wheel; eliminate yaw rate of the yawing frame
(setsym slipfw_lat "dot(vel(fw0)+Rfw*cross(rot(fw),@fw_rad),[ny])")
(add-speed-constraint "@slipfw_lat" :u "ru(yawframe)")
(dynamics)
(linear)

```

4. Decoupling of lateral and forward dynamics: $\dot{v} = 0$

Here we present in more detail why symmetry decouples lean and steer from forward motion in the linearized equations. As explained in §4 c, some configuration variables do not show up in the equations of motion and so are not of central interest. These include position (x_P, y_P) on the plane, the yaw ψ , and the net wheel rotations θ_R and θ_F . Of interest is the evolution of the right lean ϕ , the right steer δ , and backwards rear wheel rotation rate $\dot{\theta}_R$. For conceptual and notational convenience define forward speed as $v = -R_R \dot{\theta}_R$ and use v instead of $\dot{\theta}_R$ in the discussion below. First we establish the forward motion governing equation when there is no applied thrust.

Without writing explicit non-linear equations, we know they have this in-plane exact reference solution:

$$v(t) = v^*, \quad \phi(t) = 0 \quad \text{and} \quad \delta(t) = 0 \quad (\text{B } 1)$$

where v^* is an arbitrary constant.

The linearized equations are for small perturbations about this reference solution. For notational simplicity we take the lean and steer perturbations as merely ϕ and δ recognizing that we are only discussing infinitesimal values of these variables. For the forward motion take the perturbation to be \hat{v} .

For the argument below we only depend on the linearity of the equations, and not their detailed form. Take an arbitrary set of initial conditions to be $(\hat{v}_0, \phi_0, \delta_0)$. At some definite time later, say $t_d = 1$ s for definiteness, the values of the speed lean and steer at t_d must be given by

$$\begin{bmatrix} \hat{v}_d \\ \phi_d \\ \delta_d \end{bmatrix} = \mathbf{A} \begin{bmatrix} \hat{v}_0 \\ \phi_0 \\ \delta_0 \end{bmatrix} \quad (\text{B } 2)$$

for any possible combination of \hat{v}_0 , ϕ_0 , and δ_0 . The matrix $\mathbf{A} = \begin{bmatrix} A_{vv} & A_{v\phi} & A_{v\delta} \\ A_{\phi v} & A_{\phi\phi} & A_{\phi\delta} \\ A_{\delta v} & A_{\delta\phi} & A_{\delta\delta} \end{bmatrix}$ depends on which definite time t_d is chosen. Because the bicycle rolls on a flat horizontal isotropic plane and there is no time-dependent forcing, the coefficient matrix \mathbf{A} is dependent on the time interval t_d but independent of the starting time.

Now consider an initial condition 1 where only the lean is disturbed: $\begin{bmatrix} \hat{v}_0^1 \\ \phi_0^1 \\ \delta_0^1 \end{bmatrix} = \begin{bmatrix} 0 \\ 1 \\ 0 \end{bmatrix}$ where we think of 1 as a small perturbation. This results in a perturbation a

time t_d later of $\begin{bmatrix} \hat{v}_d^1 \\ \phi_d^1 \\ \delta_d^1 \end{bmatrix} = \begin{bmatrix} A_{v\phi} \\ A_{\phi\phi} \\ A_{\delta\phi} \end{bmatrix}$ where the right side is the middle column of \mathbf{A} .

Now consider the opposite perturbation 2 with $\begin{bmatrix} \hat{v}_0^2 \\ \phi_0^2 \\ \delta_0^2 \end{bmatrix} = \begin{bmatrix} 0 \\ -1 \\ 0 \end{bmatrix}$ which results in

a perturbation a time t_d later of $\begin{bmatrix} \hat{v}_d^2 \\ \phi_d^2 \\ \delta_d^2 \end{bmatrix} = \begin{bmatrix} -A_{v\phi} \\ -A_{\phi\phi} \\ -A_{\delta\phi} \end{bmatrix}$ where the right side is the negative of the middle column of \mathbf{A} ; for a linear system negating the input negates the output.

Now we invoke lateral symmetry. If knocking a bicycle to the left causes it to speed up, knocking it to the right must cause it to speed up equally. So $v_d^2 = v_d^1 \Rightarrow A_{v\phi} = -A_{v\phi} \Rightarrow A_{v\phi} = 0$.

Now we can similarly apply a rightwards perturbation to just the steer. On the one hand linearity requires a negative steer has to have the negative effect on forward speed. On the other hand, lateral symmetry requires that a rightwards steer perturbation have an equal effect as a leftwards perturbation. Thus, by the same reasoning as for lean we get $A_{v\delta} = 0$.

Next, consider perturbations to just the forward speed \hat{v} . By symmetry these can cause neither a left nor right lean or steer. So $A_{\phi v} = A_{\delta v} = 0$. Thus symmetry reduces the matrix \mathbf{A} to having zeros off the diagonal in both the first row and the first column.

Finally, we know the steady upright solution is an exact non-linear solution for any v^* . Assuming that the full non-linear equations have unique solutions for any given initial conditions, a perturbation in v^* just leads to a new constant speed solution at the perturbed v^* . Thus, $\hat{v}_d = \hat{v}_0$ and $A_{vv} = 1$.

Altogether this means that the linearized equations giving the perturbed values of the state at time t_d in terms of the initial perturbation are necessarily of the

form of equation B 2 with \mathbf{A} having the form $\mathbf{A} = \begin{bmatrix} 1 & 0 & 0 \\ 0 & A_{\phi\phi} & A_{\phi\delta} \\ 0 & A_{\delta\phi} & A_{\delta\delta} \end{bmatrix}$. This form must hold for any t_d thus perturbations in lean ϕ and steer δ never have influence on the forward speed v and vice versa, perturbations in speed have no influence on lean and steer. Similarly, lean and steer rates $(\dot{\phi}, \dot{\delta})$ are also decoupled from forward motion. Further, because $\hat{v}_d = \hat{v}_0$ for all time, \hat{v} is a constant so

$$\dot{v} = 0. \tag{B3}$$

Similar arguments show that forward forcing does not cause lean or steer and that lateral forcing does not cause changes in speed (to first order). Thus a bicycle which is forced to go at exactly constant speed in a full non-linear analysis has the same linearized lean and steer governing equations as for the bicycle that is free in forward motion. Such is confirmed by SPACAR numerical analysis where

1. For small deviations from upright both constant energy and constant speed give the same solutions (to about 9 digits) and
2. Both constant speed and constant energy give the same values for the numerical coefficients in the linearized equations. These are also the same as the values presented in the body of the paper here for our ad hoc linearization (to about 14 digits). These two comparisons were also performed by Lennartsson (2006, personal communication).

5. A simplified benchmark model

In a second benchmark various simplifications are made to permit comparison with less complete models. The design parameters are according to table 1 but with the following changes. Both wheels are planar, $I_{yy} = 2I_{xx}$, and identical with: $m_R = m_F = 3$ kg, $r_R = r_F = 0.35$ m, and $(I_{Rxx}, I_{Ryy}) = (I_{Fxx}, I_{Fyy}) = (0.14, 0.28)$ kgm². The mass of the rear frame and body assembly B is $m_B = 85$ kg located at $(x_B, z_B) = (0.3, -0.9)$ m, whereas the mass moment of inertia is zero, $\mathbf{I}_B = \mathbf{0}$. The front frame H has neither mass, $m_H = 0$, nor inertia moments, $\mathbf{I}_H = \mathbf{0}$. Substitution of these values of design parameters for the simplified benchmark bicycle in the expressions from Appendix A results in the following values for the entries in the mass matrix from (A 20),

$$\mathbf{M} = \begin{bmatrix} 69.865 & 1.868\ 727\ 853\ 976\ 56 \\ 1.868\ 727\ 853\ 976\ 56 & 0.239\ 079\ 887\ 561\ 38 \end{bmatrix},$$

the entries in the constant stiffness matrix from (A 22) which are to be multiplied by gravity g ,

$$\mathbf{K}_0 = \begin{bmatrix} -78.6 & -2.226\ 580\ 876\ 684\ 00 \\ -2.226\ 580\ 876\ 684\ 00 & -0.688\ 051\ 330\ 245\ 63 \end{bmatrix},$$

the coefficients of the stiffness matrix from (A 24) which are to be multiplied by the square of the forward speed v^2 ,

$$\mathbf{K}_2 = \begin{bmatrix} 0, & 74.779\ 149\ 614\ 579\ 71 \\ 0, & 2.306\ 586\ 620\ 338\ 71 \end{bmatrix},$$

and finally the coefficients of the ‘‘damping’’ matrix from (A 26) which are to be multiplied by the forward speed v ,

$$\mathbf{C}_1 = \begin{bmatrix} 0 & , & 29.140\ 558\ 140\ 953\ 37 \\ -0.880\ 193\ 481\ 747\ 67, & & 1.150\ 360\ 143\ 808\ 13 \end{bmatrix}.$$

To facilitate comparison with equations or results derived using different methods, eigenvalues are presented. These eigenvalues in the forward speed range show the same structure as those from the full benchmark bicycle, see figure 3, but with slightly different values. The precise eigenvalues for the simplified bicycle benchmark at some forward speeds are presented in table 3 and table 4. These results may differ from the fifteenth digit on due to the finite precision of the floating point arithmetic used. Even a reordering of term in the calculation of the intermediate expressions can have this effect.

v [m/s]	$\text{Re}(\lambda_{\text{weave}})$ [1/s]	$\text{Im}(\lambda_{\text{weave}})$ [1/s]
0	–	–
1	3.915 605 159 008 03	0.676 636 216 381 60
2	3.145 971 626 952 20	1.947 971 866 614 21
3	2.096 627 566 535 66	3.144 568 094 683 27
4	0.910 809 011 944 21	4.881 202 124 548 49
5	0.198 648 678 113 17	6.936 393 452 637 19
6	–0.245 683 866 155 55	8.903 125 360 683 31
7	–0.589 203 483 851 70	10.790 930 464 293 57
8	–0.883 875 624 871 00	12.628 966 109 587 14
9	–1.150 515 263 118 26	14.434 482 871 116 77
10	–1.399 313 952 184 76	16.217 648 368 548 84

Table 3. Complex eigenvalues λ_{weave} from the linearized stability analysis for the oscillatory weave motion for the simplified benchmark bicycle from §5 in the forward speed range of $0 \leq v \leq 10$ m/s.

v [m/s]	λ_{capsize} [1/s]	$\lambda_{\text{castering}}$ [1/s]
0	$\pm 3.321\ 334\ 354\ 955\ 67$	$\pm 5.695\ 461\ 613\ 073\ 60$
1	$-3.339\ 571\ 399\ 042\ 72$	$-6.577\ 674\ 865\ 894\ 17$
2	$-3.122\ 857\ 194\ 829\ 05$	$-7.341\ 157\ 952\ 916\ 98$
3	$-2.196\ 003\ 785\ 406\ 69$	$-8.255\ 359\ 188\ 427\ 08$
4	$-0.787\ 290\ 747\ 535\ 25$	$-9.378\ 471\ 064\ 036\ 38$
5	$-0.161\ 936\ 233\ 356\ 19$	$-10.665\ 540\ 857\ 474\ 20$
6	$0.039\ 380\ 255\ 445\ 46$	$-12.064\ 228\ 204\ 659\ 15$
7	$0.114\ 168\ 685\ 341\ 41$	$-13.538\ 013\ 346\ 083\ 71$
8	$0.143\ 031\ 193\ 913\ 90$	$-15.063\ 567\ 519\ 538\ 39$
9	$0.152\ 632\ 341\ 109\ 21$	$-16.625\ 925\ 337\ 159\ 89$
10	$0.153\ 494\ 106\ 064\ 82$	$-18.215\ 225\ 670\ 903\ 33$

Table 4. Real eigenvalues λ from the linearized stability analysis for the capsize motion and the castering motion for the simplified benchmark bicycle from §5 in the forward speed range of $0 \leq v \leq 10$ m/s.