

Your Name: _____

Your TA: _____

T&AM 203 Prelim 2

Tuesday March 28, 2000 7:30 — 9:00⁺ PM

Draft March 28, 2000

3 problems, 100 points, and 90⁺ minutes.

Please follow these directions to ease grading and to maximize your score.

- a) No calculators, books or notes allowed. Six pages of formulas from the front and back of the text are provided. The back of the test can be used for tentative scrap work. Ask for extra scrap paper if you need it.
- b) Full credit if
- ↖ • ↗ →free body diagrams← are drawn whenever linear or angular momentum balance is used;
 - correct vector notation is used, when appropriate;
 - ↑→ any dimensions, coordinates, variables and base vectors that you add are clearly defined;
 - ± all signs and directions are well defined with sketches and/or words;
 - | reasonable justification, enough to distinguish an informed answer from a guess, is given;
 - you clearly state any reasonable assumptions if a problem seems *poorly defined*;
 - work is I.) neat,
 II.) clear, and
 III.) well organized;
 - your answers are TIDILY REDUCED (Don't leave simplifiable algebraic expressions.);
 - your answers are boxed in; and
 - unless otherwise stated, you will get full credit for, instead of doing a calculation, presenting Matlab code that would generate the desired answer. To ease grading and save space, your Matlab code can use shortcut notation like " $\theta_7 = 18$ " instead of, say, "`theta7dot = 18`".
- c) Substantial partial credit if your answer is in terms of well defined variables and you have not substituted in the numerical values. Substantial partial credit if you reduce the problem to a clearly defined set of equations to solve.

Problem 1: _____/30

Problem 2: _____/35

Problem 3: _____/35

TOTAL: _____/100

1)(30 pts) **3-wheeled robot.** A 3-wheeled robot with mass m is being transported on a level flatbed trailer also with mass m . The trailer is being pushed with a force $F\hat{j}$. The ideal massless trailer wheels roll without slip. The ideal massless robot wheels also roll without slip. The robot steering mechanism has turned the wheels so that wheels at A and C are free to roll in the \hat{j} direction and the wheel at B is free to roll in the \hat{i} direction. The center of mass of the robot at G is h above the trailer bed and symmetrically above the axle connecting wheels A and B. The wheels A and B are a distance b apart. The length of the robot is ℓ .

Find the force vector \mathbf{F}_A of the trailer on the robot at A in terms of some or all of $m, g, \ell, F, b, h, \hat{i}, \hat{j}$, and \hat{k} .

[Hints: Use a free body diagram of the cart with robot to find their acceleration. With reference to a free body diagram of the robot, use angular momentum balance about axis BC to find F_{Az} .]

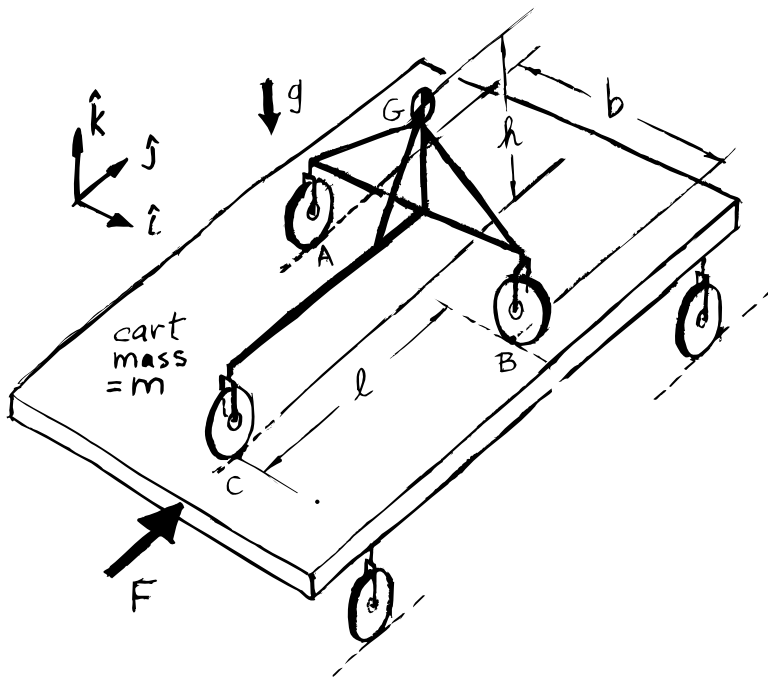

(Continue work for problem 1 here)

2)(35 pts) **Slippery money.** A round uniform flat horizontal platform with radius R and mass m is mounted on frictionless bearings with a vertical axis at O . At the moment of interest it is rotating counter clockwise (looking down) with angular velocity $\underline{\omega} = \omega \hat{\mathbf{k}}$. A force in the xy plane with magnitude F is applied at the perimeter at an angle of 30° from the radial direction. The force is applied at a location that is ϕ from the fixed positive x axis. At the moment of interest a small coin sits on a radial line that is an angle θ from the fixed positive x axis (with mass much much smaller than m). Gravity presses it down, the platform holds it up, and friction (coefficient= μ) keeps it from sliding.

Find the biggest value of d for which the coin does not slide in terms of some or all of $F, m, g, R, \omega, \theta, \phi,$ and μ .

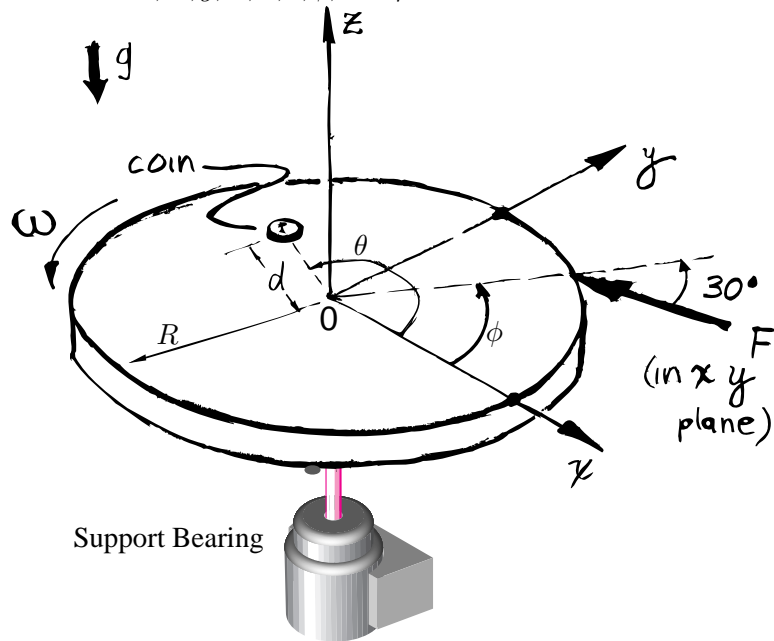

(Continue work for problem 2 here)

- 3) 35 pts) **Cone on Disk.** A disk rotates with constant rate ω about a fixed axis in the $\hat{\mathbf{j}}$ direction. A right cone held in a fixed bearing at B rolls at constant rate so that the point on the corner of the edge of the cone has the same velocity as the point it touches on the disk, $\mathbf{v}_C = \mathbf{v}_D$. Axis AB is in the xy plane. Find the velocity and acceleration of point C on the cone in terms of some or all of $\omega, r, \beta, \hat{\mathbf{i}}, \hat{\mathbf{j}}$, and $\hat{\mathbf{k}}$.

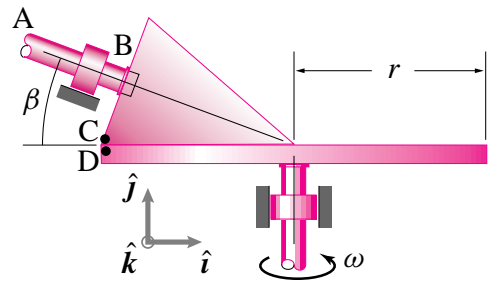

(Continue work for problem 3 here)