

An Olympic Question:

Write out the equations that describe the motion of a discus (a heavy spinning disk) after it leaves the competitor's hand. Start with the simplest possible assumptions. What is the motion?

Discuss how this model may be made more realistic. What new features will appear in the motion? How do these features arise in the solution.

Orbit Hi-Spin Discus 1k

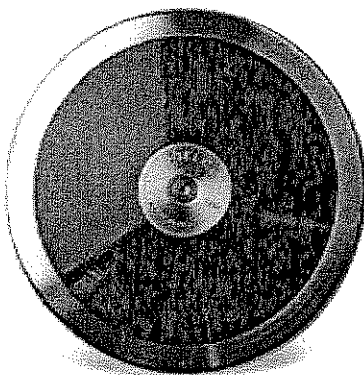

Model Number: T82

~~Retail Price: \$193.70~~
Our Price: \$149.00

Designed for championship performance, this discus has a rim weight of 80-85% and is the preferred discus of top class throwers. High-impact resistant black ABS side plates, combined with a stainless steel rim, make this one of the best discus in the world.



Discus Videos

DYNAMICS Committee: Ruina, Burns, Healey* Phoenix

Question 1:

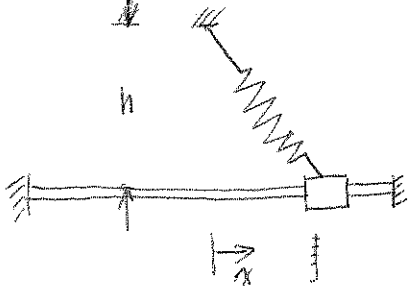

1. if $h > l$, write the motion equation(s).
2. if x is small, describe the motion.
3. if $h < l$, what happens?

Question 2:

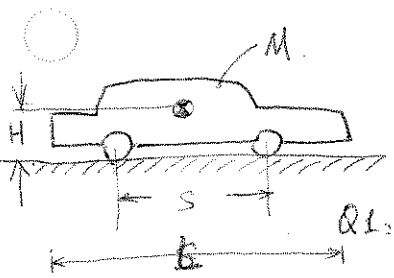

The wheels roll without friction on their axes. The friction parameter of the ground is μ . You can choose Front or Rear wheel to be the driven wheel. what is the ^{maximum} ~~minimum~~ acceleration of the car. (Note: assume non-driven wheel pure-rolling for on the

Q2: Which dimensions might affect the ^{maximum} acceleration: H, L, S, or M?

Question 3:

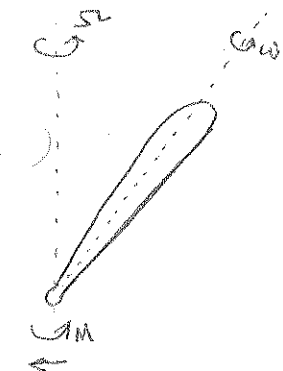

a baseball bat rotates with constant α & ω as shown on the left. (1) Find the moment on the bottom. (magnitude and direction) (2) " " Force needed.

Dynamics

08/23/2002

Q1)

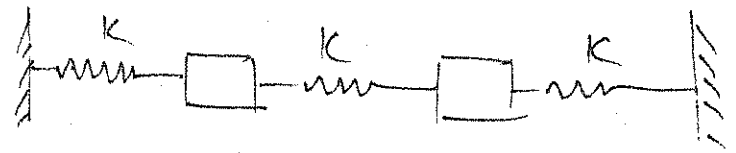
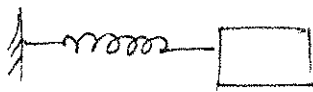

What is resonance, natural frequency, normal modes...

Q2)

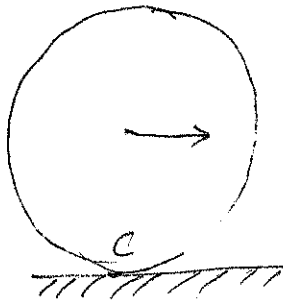

v_0, a_0

find ω, a_c, v_c etc

Q3)

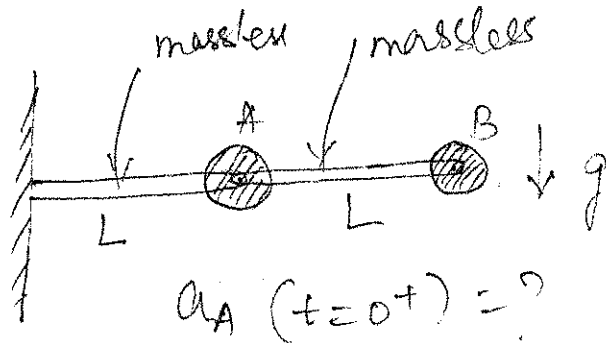

$a_A (t=0^+) = ?$

Dynamics

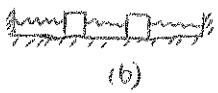
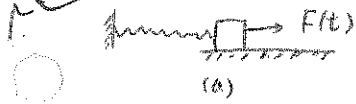

- ① Explain what is natural frequency? what is resonance?
- ② what is natural modes? where are the natural modes of (b)? what are the frequencies of the natural modes?

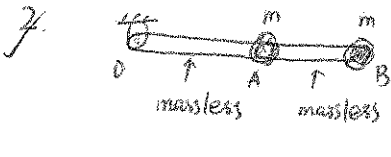

g

Double Pendulum, released from the current position. what are the accelerations of A and B?

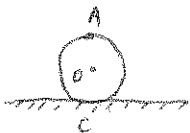

Given v_0 α_0

- ① Find v_c a_c ?
- ② Find v_A a_A ?
- ③ If there is wind coming from right, all the masses concentrates in A. what are the forces acting on A? what is total force?

Solid Mechanics

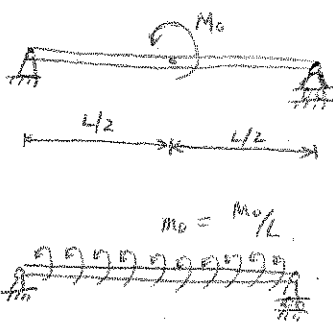

- ① Find the distribution of shear force and moment in the beam, and draw them.
- ② what if there is a distributed moment $m_0 = \frac{M_0}{L}$?

2. what is stress? what is traction? what is the difference between stress in solid and stress in fluid? Find the stresses in the fluid:



Dynamics

1. Derive eq(s) w/ Lagrange: (Burns)

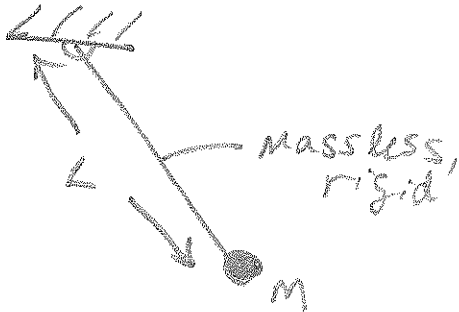

Describe 2 other ways to derive eq(s) of motion.

2.

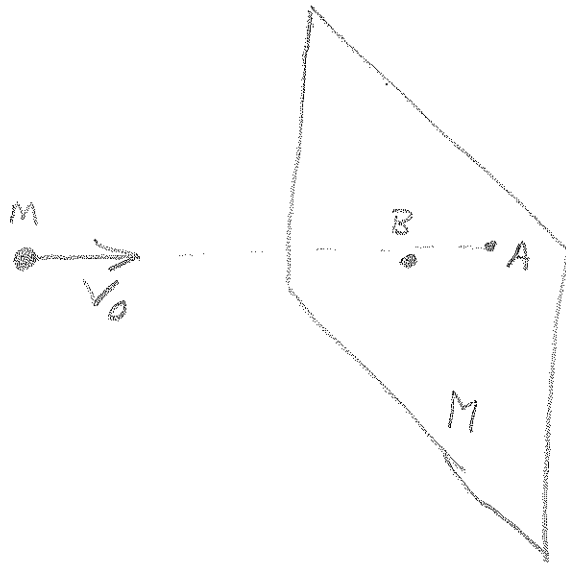

(Ruina)
Particle collides and sticks at A.

Is L conserved?
Is A conserved?
Is E conserved?

About what points?
for what systems? (particle, plate, or particle + plate)

Setup the problem to solve for the subsequent motion.

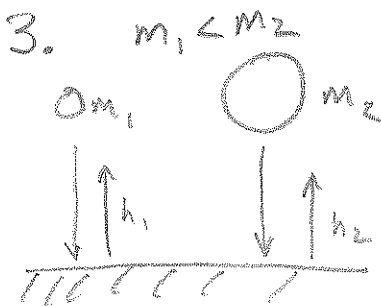

When m_1 and m_2 bounce they return to heights h_1, h_2 respectively. (Approximately the same.)

Explain \rightarrow

(Zehnder)
When dropped this way:

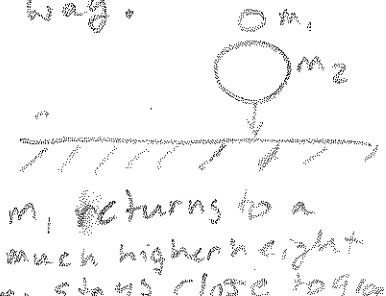

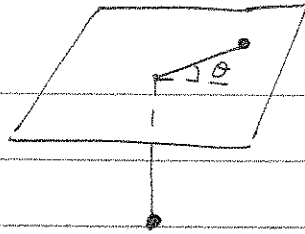

Problem 1.

- How many degrees of freedom?
- Are there any conserved quantities?
- Find the equations of motion.

Problem 2.

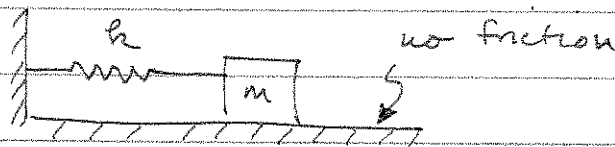

- What is the natural frequency?
- Now, suppose the spring has mass M , what is the new natural frequency?
- Some other stupid questions...

Problem 3.

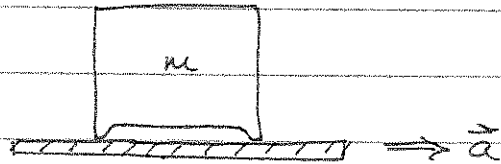

Floor has constant acceleration \vec{a} , block is at rest at $t=0$

- What happens?

1

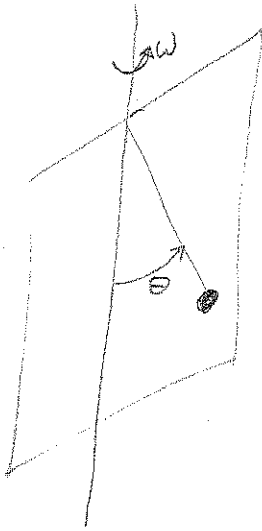

PENDULUM CONFINED TO A PLANE
ROTATING AT ANGULAR VELOCITY ω .

FIND EQUATIONS OF MOTION USING LAGRANGE.

2

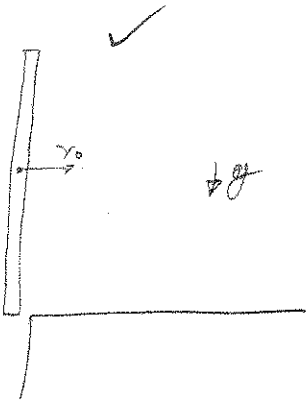

A THIN ROD MOVING HORIZONTALLY WITH
VELOCITY v_0 BARELY STRIKES A TABLE
IN AN INELASTIC COLLISION - THEN
ROTATES ABOUT THE IMPACT POINT
UNDER INFLUENCE OF GRAVITY.

WHAT IS THE FINAL MOTION OF THE ROD?

3

✓ WRITE OUT EQUATIONS OF MOTION FOR A
RIGID BODY ROTATING ABOUT ITS
CENTRE OF MASS.

DYNAMICS

January, 2000

①

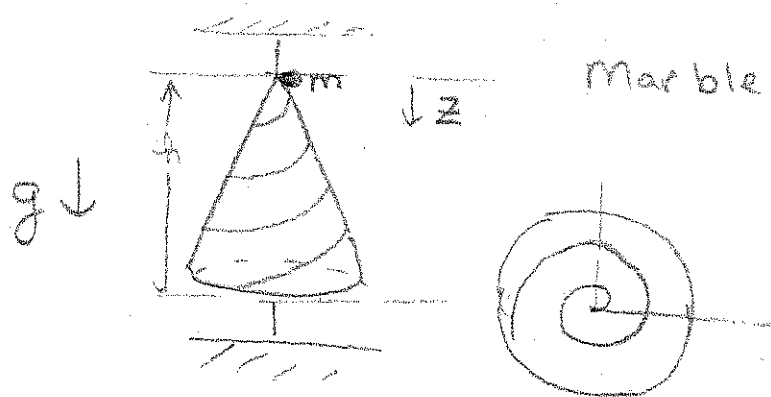

Marble mass m

$$r = z = 0$$

marble travels through a frictionless tube

a) find velocity when marble reaches bottom of cone

b) the cone can spin do (a) again

②

double pendulum

derive equations of motion

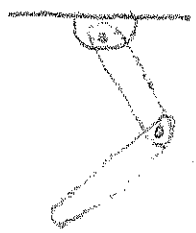

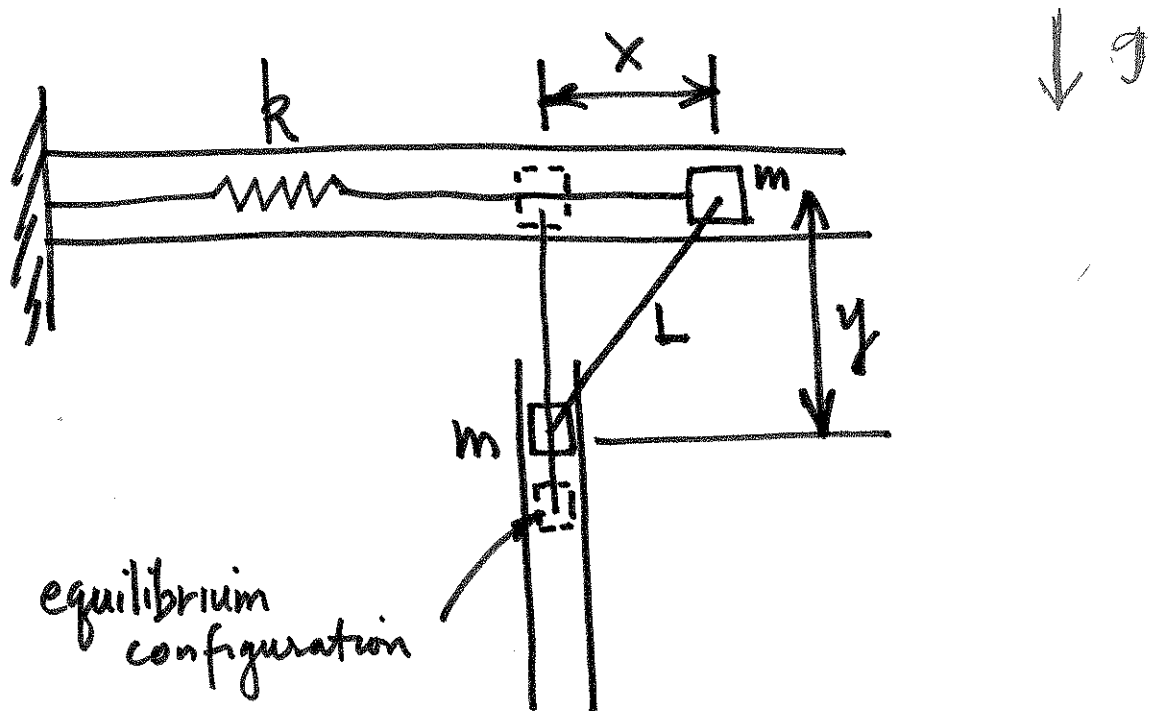

Derive the equation of motion.

Assumptions

$L =$ rigid rod

neglect friction

include gravity

Use any method you like.

Jan 98.

Dynamics:

(1)

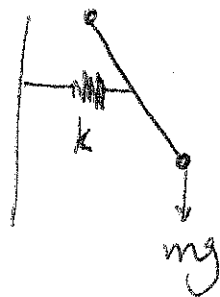

spring + pendulum.

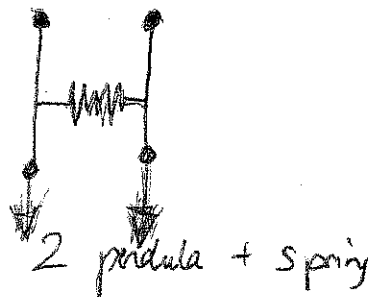

2 pendula + spring

(2) $\dot{x} = x^2 - xy$?
 $\dot{y} = xy + y^2$?

DISCUSS - if linearize, stability, phase plane diagram integrable?

(3) pure elastic collision of 2 balls (no gravity)

Use conservation of momentum or ... ?

- 9) A particle travels in a circular path on the inside of a cone. Find its speed v as a function of θ .

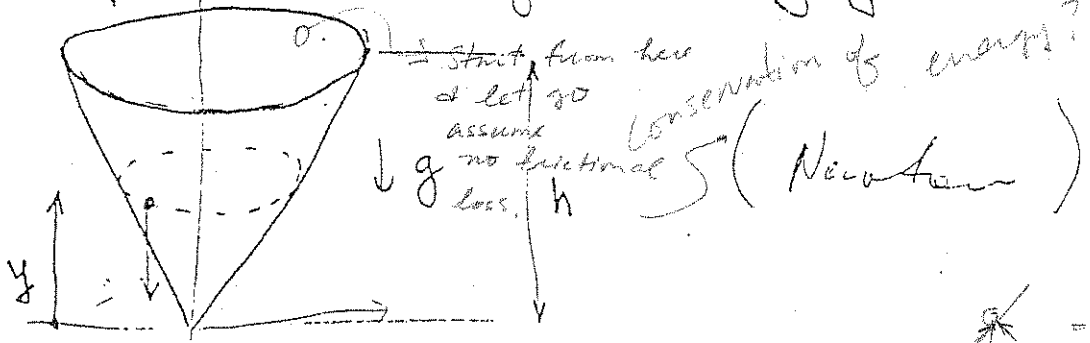

1

- 10) A particle travels along a helical spring, until it reaches the end of the spring and falls off. What is its trajectory?

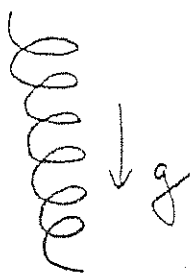

$$\begin{aligned}
 \vec{r} &= \rho \cos t \hat{i} + \rho \sin t \hat{j} + at \hat{k} \\
 \dot{\vec{r}} &= -\rho \sin t \hat{i} + \rho \cos t \hat{j} + a \hat{k} \\
 \ddot{\vec{r}} &= -\rho \cos t \hat{i} - \rho \sin t \hat{j} \\
 \Rightarrow \vec{F} &= -\rho (\cos t \hat{i} + \sin t \hat{j}) \\
 \vec{F} &= -\rho (\cos t \hat{i} + \sin t \hat{j}) - g \hat{k} \\
 &= -\rho \cos t \hat{i} - \rho \sin t \hat{j} - g \hat{k} \text{ constant}
 \end{aligned}$$

1

- 11) a) State Newton's 3 laws.
 b) D'Alembert's Principle (Notes)
 1st law = particle at rest remain at rest unless acted upon by external forces.
 2nd law = change in \vec{p} particle when acted upon by external force is $F = \frac{d\vec{p}}{dt}$
 3rd law = equal & opposite forces.
 D'Alembert's principle = reaction forces or force of constraints does no work under virtual displ.

- 12) Find the altitude of a geosynchronous orbit.

2

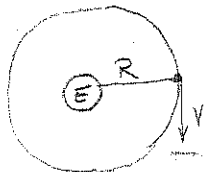

geosynchronous

$$\frac{mv^2}{R} = G \frac{mM_e}{R^2} \quad R\dot{\theta} = v \quad \text{sidereal da} \quad \dot{\theta} \Delta t = 360$$

Note: Geosynchronous orbit is a circular orbit that completes one full revolution about the earth in one sidereal day.

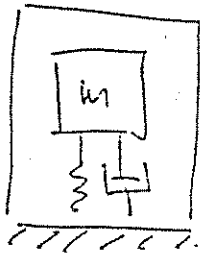

53

Puls hammer? Discus!
 How to measure the force?
 Equation of the mechanism inside
 the hammer?

2

54

What is constraint? Limitation placed on
 the degrees of freedom
 a system can have.

1

Usually, it has the form of
 an equation relating the different
 degrees of freedom. Hence reducing
 the # of independent degrees of
 freedom.

55

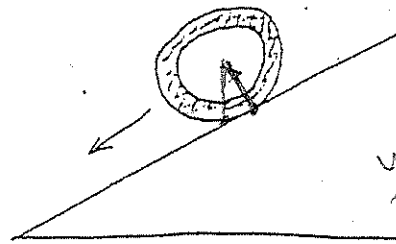

use momentum
 principle
 is better.

1

- a) Solve the problem:
- (i) with slippage
 - (ii) without slippage

b) What are restrictions on $\vec{T} = \frac{d\vec{L}}{dt}$
 fixed pt in space or CM.

c) Where is the above equation derived
 from? $\vec{F} = m\vec{a}$

50. Spherical pendulum ($\dot{\theta} = 0$)
 Given an I.C. on ψ , find the period.
 If the mass is given a slight disturbance
 ($\dot{\theta}$ no longer = 0), find the period!

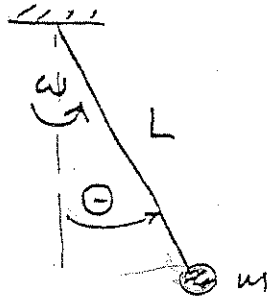

1

$$T = \sqrt{\frac{g}{R}} 2\pi$$

$$EOM: \ddot{\theta} + \frac{g}{R} \sin\theta \cos\theta = 0$$

51

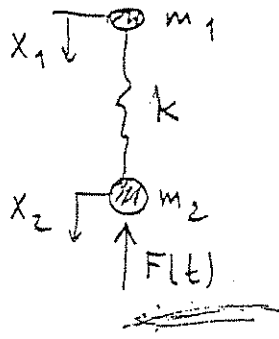

Set up eqs of motion.
 Given $(\dot{x}_1 - \dot{x}_2)$ how would you find $F(t)$?

1

$$\left. \begin{aligned} m_1 \ddot{x}_1 - k(x_2 - x_1) &= 0 \\ m_2 \ddot{x}_2 + k(x_2 - x_1) &= F(t) \end{aligned} \right\}$$

52

What is the difference between LE and NE's?

1

AUG 25, 1995

JOHN WEISENFELD

1.)

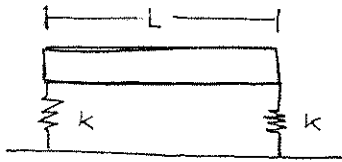
 M, L

(Stragatz)

discuss dynamics of small amplitude motion,

2.)

Find escape velocity from the earth's surface

(Burns)

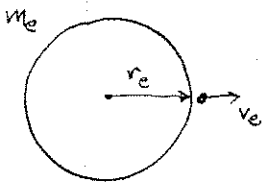

3.)

A ball rolls on a plane in 3-D, discuss dynamics,
make any assumptions that you need

(Ruina)

Dawson, MacDonald

Dynamics

192
Summer

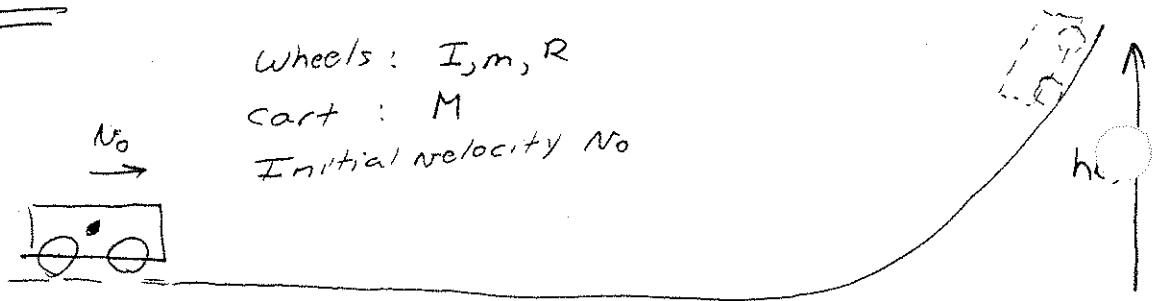

Wheels: I, m, R
 Cart: M
 Initial velocity v_0

How far up does it go?

What is a conservative force?
 Which of the forces are conservative?
 General free body diagram.
 Why do we use energy?

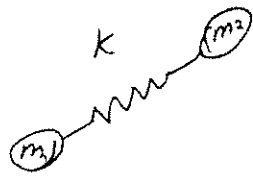

How many ~~degrees~~ degrees of freedom?
 Is $k \rightarrow \infty$, again?

Equations of motion.
 Any other ways?

Spinning Objects

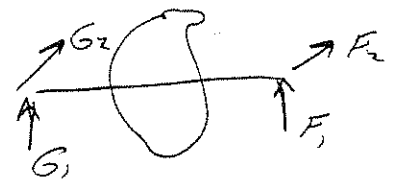

When are reactions zero?

Explain rotations of each.

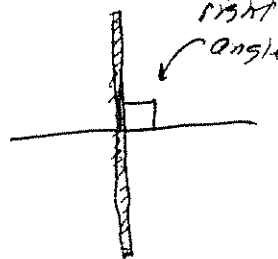
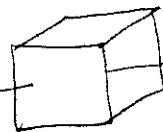

That's supposed to be a cube

All through cm.

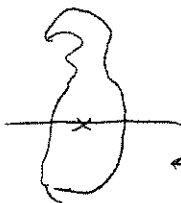

← arbitrary planar object

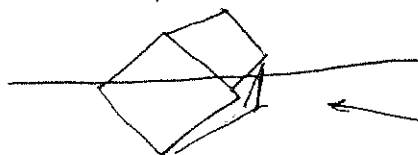

← arbitrary orientation (over)

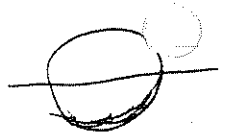

Sphere

A

50

Spherical pendulum ($\dot{\theta} = 0$)
 Given an i.c. on ψ , find the period.
 If the mass is given a slight disturbance
 ($\dot{\theta}$ no longer = 0), find the period!

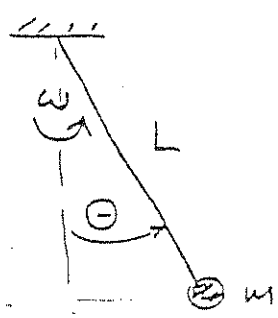

1

$$\omega^2 = \frac{g}{L \cos \theta}$$

$$v = \omega (L \sin \theta)$$

Period $T = T(\theta)$

Determine new steady state.

θ' , v'

Energy Conservation.
 $v = v(\theta)$

51

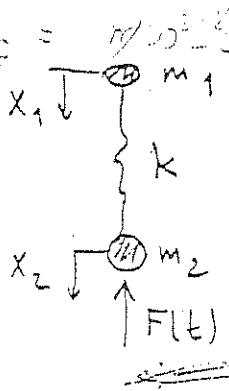

Set up eqs of motion.
 Given $(\dot{x}_1 - \dot{x}_2)$, how would you find $F(t)$?

1

... not well-posed.

52

What is the difference between LE^1 and NE^1 s?
 1) No superposition
 2) Solutions depend on i.c.

1

↑
D
↓

(B) DYNAMICS

(Aug 95)

1. Find the natural frequencies of the following system.

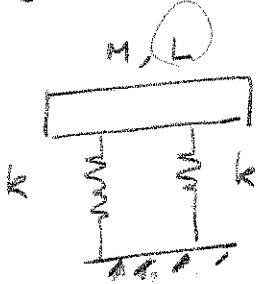
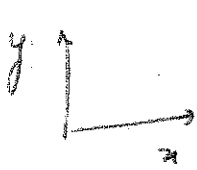

(a) Assume no motion in x -direction.

$\frac{7k}{m}$ (translational), $\frac{kL^2}{2I}$ (rotational).

(b) (Lucia) What is the frequency in the x -direction? Is this a valid question? If the motion is large. For small vibration I don't think there is any motion in the x -direction (1st order).

2. (J. Burns) (a) Find the escape velocity of a particle from the Earth. (Mass M_e , radius R_e)



$-\frac{M_e M G}{R_e} + \frac{1}{2} M v_{esc}^2 = 0$

Note that $\frac{M_e G}{R_e^2} = g$.

$\Rightarrow \frac{1}{2} M v_{esc}^2 = \frac{M_e M G}{R_e} \Rightarrow v_{esc} = \sqrt{\frac{2 M_e G}{R_e}} = \sqrt{2g R_e}$

(b) Find the escape velocity of a particle from the Earth - Sun system?

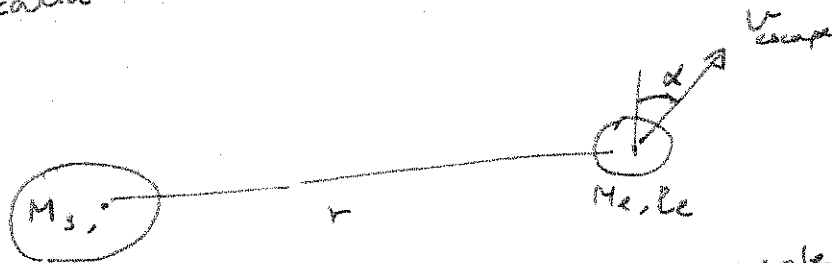

(c) In the first case one neglected the spin of the Earth. Why? Is this justified? What about the second case?

(Lucia) A ball is set rolling on the floor with general initial conditions. (3 component velocity in plane parallel to the ground), general motion (qualitative). (a) What is the transient slip? (b) Once the transient dies out what is the final state of motion (quantitative)?

(63)

Thin plate in $y-z$ plane!

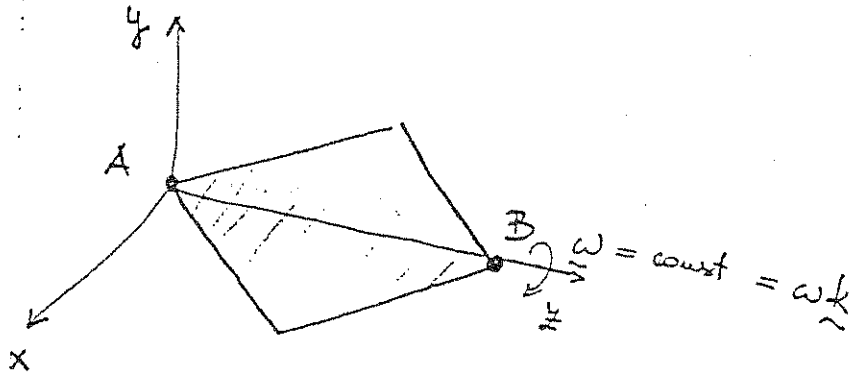

How do you find reactions at A and B?
(dynamic reactions) reactions

1

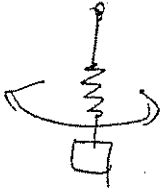

THEORETICAL AND APPLIED MECHANICS

QUALIFYING EXAMINATION

January 22, & 23 1987

Dynamics

D.1 Dynamics of a Swing

Discuss the dynamics of pumping a swing:

Taking the rider to be a point mass, derive the equation of motion for a variable length pendulum. Find an approximate equation of motion by considering the length variations to be small and sinusoidal. Discuss the stability of this equation, perhaps using a perturbation analysis to find an approximate solution to it.

Give some discussion of how conservation principles may be used to understand the increasing amplitude of the vibration.

References: T.E. Stern, Theory of Non-Linear Networks and Systems-Introduction;

P. Tea and H. Falk, Am. Jnl. Physics, Dec. 1968.

D.2 Yo-Yo

Describe, using mechanics, the operation of a yo-yo.

D.3 Rotating Celestial Bodies

- a) A spacecraft, composed of an inelastic material, is spinning and tumbling freely in space with an initially randomly chosen orientation of the angular momentum to the body's principal axes. Describe the final mode of spin that the body will adopt and explain why.
- b) Most natural satellites rotate so as to present approximately the same face to their planets all around their orbits. Discuss what orientation the principal axes of the satellite will have in relation to its orbit and its planet.

D.4 Spinning Egg

Discuss the dynamics of a spinning egg. Consider four cases: raw egg, soft-boiled, hard-boiled, empty shell (but intact).

D.5 Collisions of Two Rigid Bodies

Two rigid bodies of mass m_1 and m_2 collide in space. At the moment of impact, they contact along a common tangent plane having a normal, \underline{n} , to the plane. Body #1 moves with angular velocity $\underline{\omega}_1$ and linear velocity \underline{v}_1 (of its center of mass), and Body #2 moves with $\underline{\omega}_2$ and \underline{v}_2 .

- a) Based on the dynamical principles involving linear momentum and angular momentum and an empirical law for collisions, derive the equations of motion for the unknown velocities \underline{v}'_1 , \underline{v}'_2 and angular velocities $\underline{\omega}'_1$, $\underline{\omega}'_2$ of the two bodies after impact. Assume the surfaces of contact are so rough that the bodies collide without slipping at the contact point.

b) Illustrate the solution of the equations of motion for the simplified case when one body is a sphere of radius r_0 and the second body is a stationary half space. The sphere hits the rough surface of the half space with linear velocity $\vec{v}_1 = v\cos\theta\vec{i} + v\sin\theta\vec{j}$ and zero angular velocity ($\vec{\omega}_1 = 0$).

Reference: Greenwood, Principles of Dynamics, Chs. 4 and 8.
E.T. Whittaker; Analytical Dynamics, Sections 95-97.

D.6 Billiards

Discuss the mechanics of billiards. Consider the effects of impacts, friction, impure roll, and wall interactions.

References: Greenwood; Principles of Dynamics
Summerfield, Mechanics

D.7 Bodies Connected by a String

Consider the physical problem to two moving masses connected by a massless inextensible string as shown in figure:

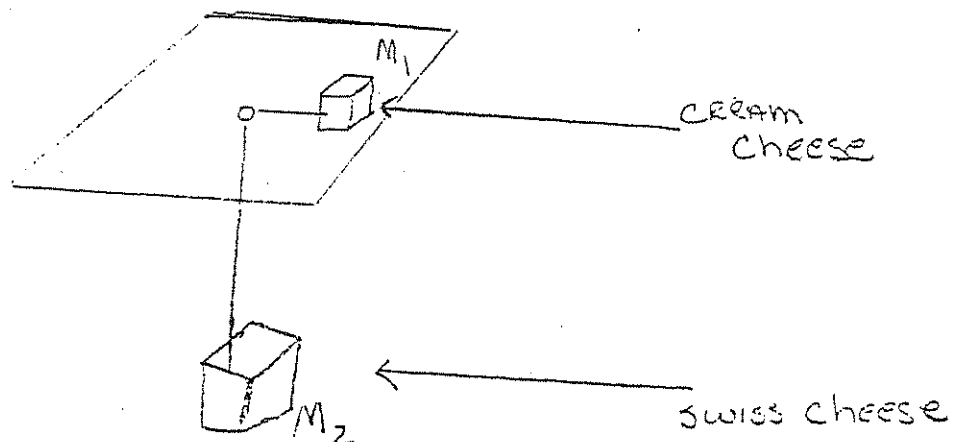

Derive the equations of motion of the system, stating clearly all your assumptions. Can you solve the equations?

D.8 Control of Dynamical System

The figure shows a cart on which is mounted a rod, hinged as shown. The designer has at his disposal the forcing function $F = F(x, \dot{x}, \theta, \dot{\theta})$. He would like to choose this function (design the system) so that the motion of the cart will keep the rod in balance. The track extends only from $x = -a$ to $x = +a$. Thus the idea is to choose $F(x, \dot{x}, \theta, \dot{\theta})$ so that

$$-a < x < a$$

$$-\pi/2 < \theta < \pi/2$$

hold for all t .

1. Set up the differential equations of motion.
2. Even if you can't come up with a design, discuss how one might go about it, the difficulties involved (both practical and theoretical), what effect it would have if F were restricted to be "bang-bang" i.e. F can only be $+F_0$ or $-F_0$, range of initial conditions, etc.

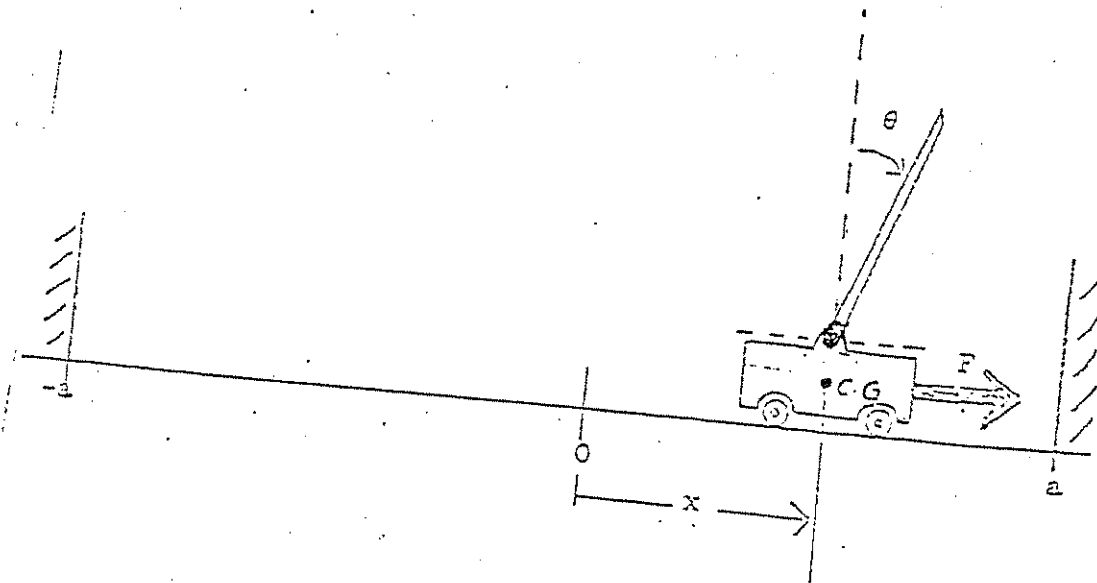

I. COLLISIONS OF RIGID BODIES.

Two bodies of mass m_1 and m_2 collide as shown in the figure. At the moment of collision, they contact at point P with a common tangent plane and a normal, \vec{n} , to that plane. We are in general given:

$$\vec{v}_1, \vec{v}_2, \vec{\omega}_1, \vec{\omega}_2 \text{ before impact,}$$

and wish to determine:

$$\vec{v}'_1, \vec{v}'_2, \vec{\omega}'_1, \vec{\omega}'_2 \text{ after impact.}$$

The twelve unknown quantities (4 vectors) are related to the given quantities by the empirical law of collision and equations for impulsive motion:

$$\int_0^{\Delta t} \vec{F} dt = [m \vec{v}_c]_0^{\Delta t} \quad \text{Linear momentum}$$

$$\int_0^{\Delta t} \vec{M} dt = [\vec{H}]_0^{\Delta t} \quad \text{Angular momentum}$$

The twelve equations are:

(1) Law of Collisions - When two bodies collide, the values of the normal component of the relative velocity of the surfaces in contact at instants immediately after and immediately before the impact bear a definite ratio to each other; this ratio, denoted by $-e$, depends only on the material of which the bodies are composed (one eq.).

$$-e = \frac{\vec{v}'_{1p} \cdot \vec{n} - \vec{v}'_{2p} \cdot \vec{n}}{\vec{v}_{1p} \cdot \vec{n} - \vec{v}_{2p} \cdot \vec{n}}$$

where

$$\vec{v}_{1p} = \vec{v}_1 + \vec{\omega}_1 \times \rho_1 \text{ etc.}$$

(2) Constancy of angular momentum of each body about the point of contact, p, because of zero moment about p (six eqs.).

$$\vec{L}_p = 0.$$

(3) Constancy of linear momentum of the system (two bodies) normal to the surface of contact because of equal and opposite normal impulses (one eq.)

$$(m_1 \vec{v}_1 + m_2 \vec{v}_2) \cdot \vec{n} = (m_1 \vec{v}'_1 + m_2 \vec{v}'_2) \cdot \vec{n}.$$

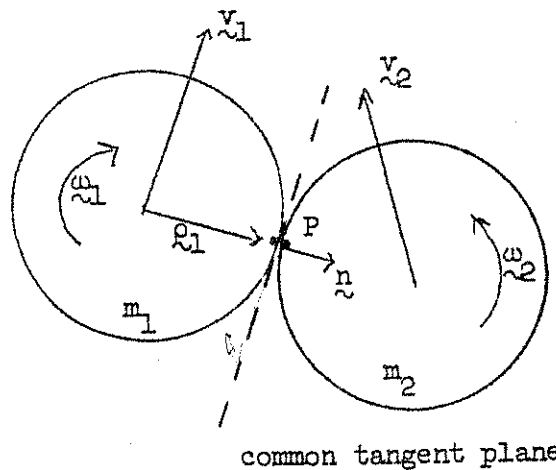

- (4A) For smooth surfaces - No change in tangential components of the linear momentum for each body because of zero tangential forces (four eqs.)

$$\underline{\hat{n}} \times (m\underline{\hat{v}}' \times \underline{\hat{n}}) - \underline{\hat{n}} \times (m\underline{\hat{v}} \times \underline{\hat{n}}) = 0$$

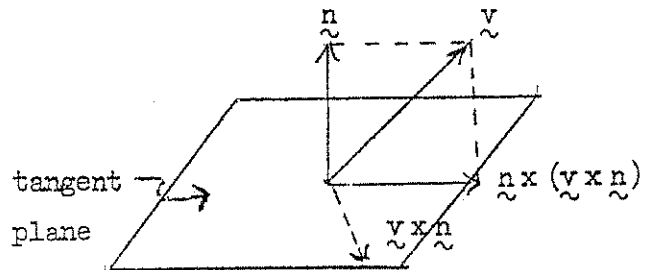

- (4B) For Rough Surfaces without Slipping at the Contact Point
- (i) Constancy of tangential components of the linear momentum of the system because of equal and opposite tangential impulses (two eqs.)

$$\underline{\hat{n}} \times [(m_1 \underline{\hat{v}}_1 + m_2 \underline{\hat{v}}_2) \times \underline{\hat{n}}] = \underline{\hat{n}} \times [(m_1 \underline{\hat{v}}_1' + m_2 \underline{\hat{v}}_2') \times \underline{\hat{n}}]$$

- (ii) Vanishing of the tangential components of the relative velocity of the two bodies after impact because of no slipping constraint (two eqs.)

$$\underline{\hat{n}} \times [(\underline{\hat{v}}_2' - \underline{\hat{v}}_1') \times \underline{\hat{n}}] = 0.$$

- (4C) For Rough Surfaces with Slipping at the Contact Point

- (i) Same as (4Bi) (two eqs.)
- (ii) Change of the components of the linear momentum by the tangential impulse which equals, in magnitude to μ (coefficient of friction) times the normal impulse for each body (two eqs.)

$$|\underline{\hat{n}} \times [m(\underline{\hat{v}}' - \underline{\hat{v}}) \times \underline{\hat{n}}]| = \mu m (\underline{\hat{v}}' - \underline{\hat{v}}) \cdot \underline{\hat{n}}$$

Note that there are two equations of the above form for each body; a total of 4 equations is obtainable. However, only two (for either body) are independent equations.

DYNAMICS

1. An elastic beam ^{with} simple support can be modeled as a harmonic oscillator (mass supported by a spring).
The beam is subjected to the time varying force $\vec{F} = F \delta(t) \hat{j}$

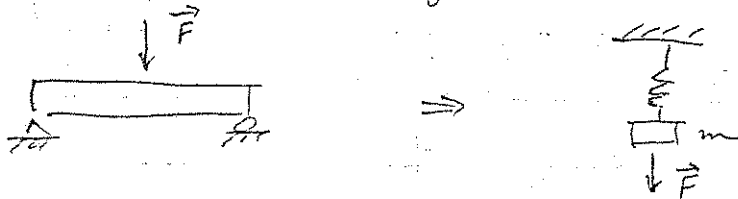

- What is the equation of motion?
Solve it for $y(t)$ when $\vec{F}(t) = F \delta(t - \tau) \hat{j}$

2. A rectangular plate of constant thickness spins about an axis. What moment is exerted on the supports by the plate.

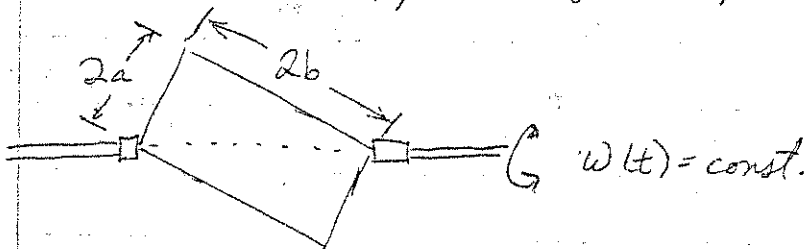

Dynamics

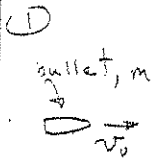

Bullet strikes pendulum (hard) and is embedded. What is maximum angle θ of subsequent motion of the pendulum?

② Discuss nature of angular momentum and relevant equations (Plan) for a spacecraft. What are the equations? What about other formulations?

③ What constraints are there on the choice of reference frames (Barua) for using the equations $\Sigma \vec{L} = \dot{\vec{L}}$, $\Sigma \vec{F} = m\vec{a}$? What is an inertial reference frame?

④ There was an apparatus:
Prof Sarkar pulled the mass down and released it.

What is the nature of the motion?

What is the equation of motion?

When is force in the sensor of maximum magnitude?

How would you verify that the motion obeys the solution to the equation of motion?

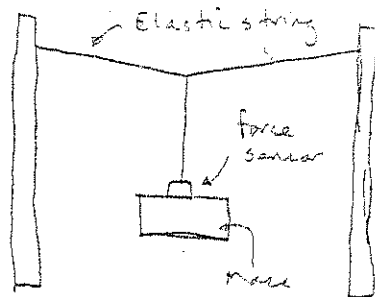

(Sarkar)

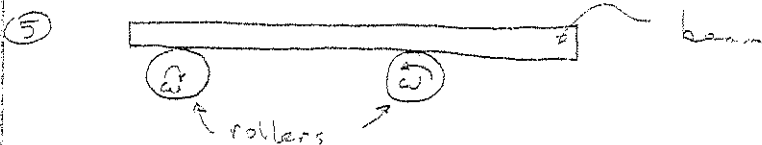

(Zakharov)

There is friction between rollers and beam. What is the nature of the motion and what is the equation of motion?

Jan 21.

Examinee G. Zhang

1. Dynamics.

Questions: 1) A rule initially lies on a table supported by hand, then withdraw the hand. Describe Derive equations of motion.



What is the relationship between the angular velocity $\vec{\omega}$ and the velocity of mass center?

2) 



Derive the velocity and acceleration.

3)



given constant $\vec{\omega}$, find θ .

How many method can you use?

4). There ~~is~~ was an experimental set-up, an oscilloscope and a hammer attached to it. Prof. Sachse gives a small blow to the cable with hammer and asks to explain what the pulse on the screen indicates?

What is inside the hammer?

Write down the equation for the mechanism inside the hammer. Explain how to measure the force?

5). What is the difference between Newton's method ~~equation~~ and Lagrange ~~equation~~ method. What is constraint?

Dynamics

①

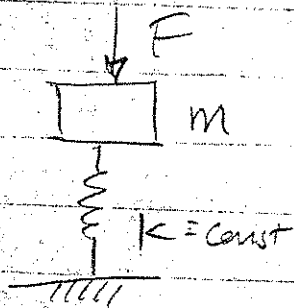

- Impact load is applied
- How do you solve for displacement of mass?
($m\ddot{x} + kx = F\delta(t-t_0)$ ← supplied by student)
↳ const.
- What are initial conditions?
- What is the solution?
- How do you apply boundary conditions?
- How do you solve for arbitrary excitation

②

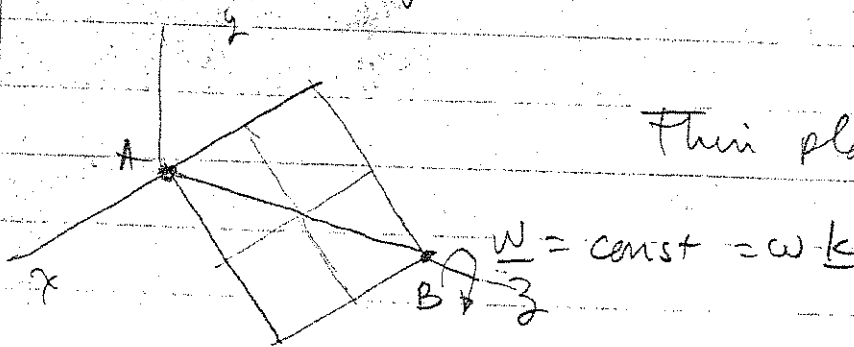

Thin plate in $y-z$ plane

How do you find reactions at A and B?
(dynamic reactions)

Dynamics

1. Derive a formula for escape velocity in terms of "known" quantities for
 - ① earth - satellite
 - ② Sun - earth - satellite systems.

(Known \rightarrow g, year, 24 hrs, distances; no masses, g)

Kepler's law.

2. Express angular velocity as a matrix (not vector)
3. Why does potential energy have a -ve sign?

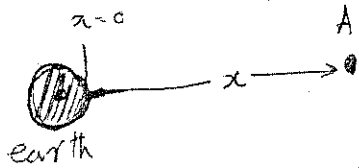

What is Pot. En. at A for $x \geq 0$ & $x = \infty$?

general \rightarrow • You should be able to ~~fully~~ fully justify every statement you make.
• Better to write your answers rather than just say it.

Dynamics

1)

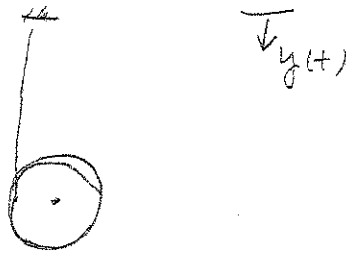

Spool with string falling down

a) find $y(t)$

b) will it swing?

2)

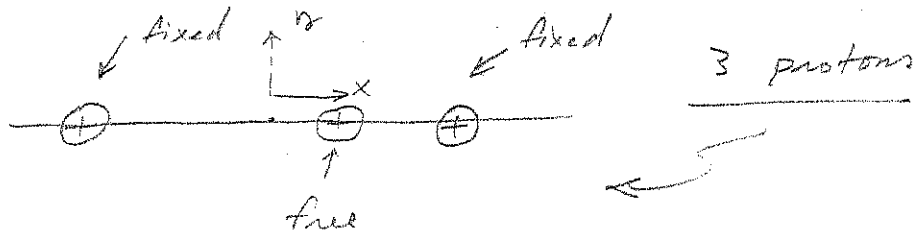

Discuss the stability of the free proton?

3)

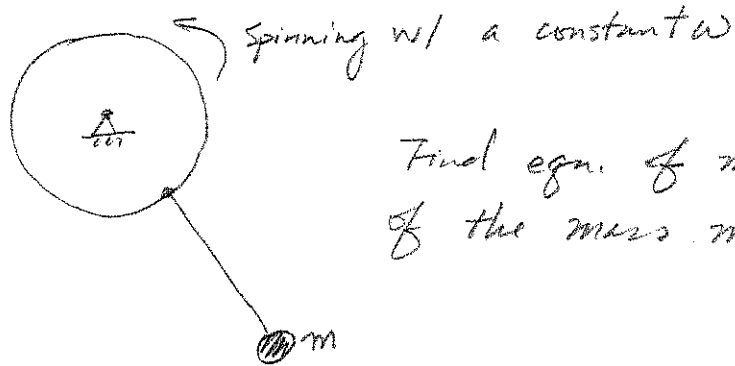

Find eqn. of motion of the mass m .

Dynamics

4) Suppose there's a chair ^{How can one} find the principal moment of inertia of the chair?

Robot Poek

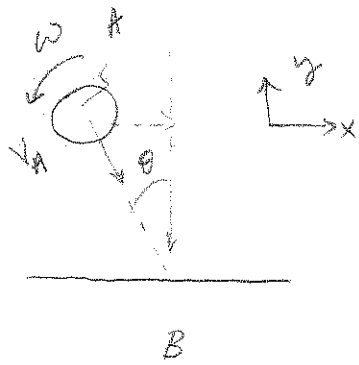

at impact

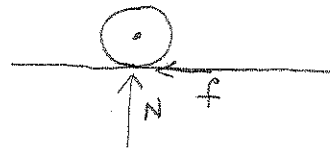

write impulse momentum equation

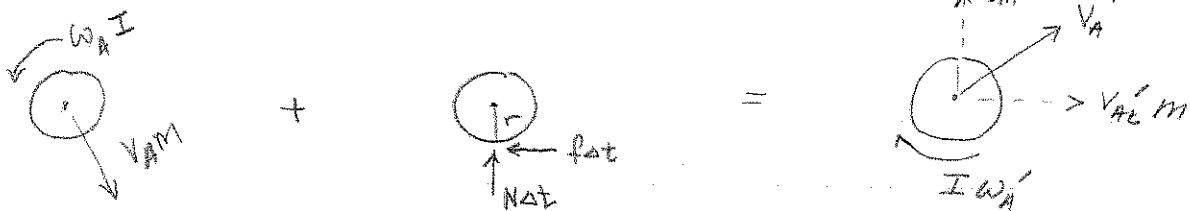

given normal component is elastic

$(v_{Bn}' - v_{An}') = e (v_{An} - v_{Bn})$ memorize this thing

elastic $\Rightarrow e = 1$ $v_{Bn} = v_{Bn}' = 0 \rightarrow$ wall.

$\Rightarrow -v_{An}' = v_{An}$ or $v_{An}' = -v_{An} = +v_A \cos \theta$

$x: m v_A \sin \theta - f \Delta t = m v_{A2}'$

$y: -m v_A \cos \theta + N \Delta t = m v_{A2n}' = m v_A \cos \theta$

$\uparrow + \curvearrowright: I \omega_A - f \Delta t r = -I \omega_A'$

v_{A2}' , ω_A' , $f \Delta t$, $N \Delta t$ 4 unknowns 3 equations.

need one more equation

Assume friction force related to N , i.e., $f = \mu N$

$\Rightarrow f \Delta t = \mu N \Delta t$ This gives the 4th equation needed to solve for everything.

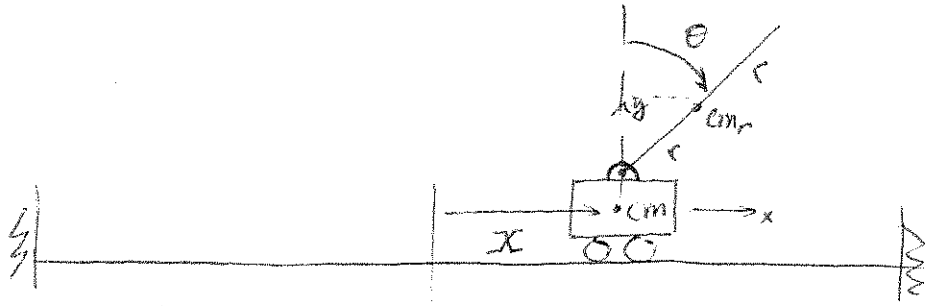

Length of rod is \$2r\$. Attach a coordinate system to the cart.

$$\underline{r}_{cmr} = X \underline{e}_1 + r \sin \theta \underline{e}_1 + r \cos \theta \underline{e}_2$$

note that \$\underline{E}_1 = \underline{e}_1\$

$$\Rightarrow \underline{r}_{cmr} = (X + r \sin \theta) \underline{e}_1 + r \cos \theta \underline{e}_2$$

$$\dot{\underline{r}}_{cmr} = (\dot{X} + r \dot{\theta} \cos \theta) \underline{e}_1 - (r \dot{\theta} \sin \theta) \underline{e}_2$$

$$\begin{aligned} \dot{\underline{r}}_{cmr} \cdot \dot{\underline{r}}_{cmr} &= (\dot{X} + r \dot{\theta} \cos \theta) \cdot (\dot{X} + r \dot{\theta} \cos \theta) + (r \dot{\theta} \sin \theta) (r \dot{\theta} \sin \theta) \\ &= \dot{X}^2 + 2 \dot{X} r \dot{\theta} \cos \theta + r^2 \dot{\theta}^2 \end{aligned}$$

$$T = \frac{1}{2} m_{rod} (\dot{X}^2 + 2 \dot{X} r \dot{\theta} \cos \theta + r^2 \dot{\theta}^2) + \frac{1}{2} m_{cart} \dot{X}^2 + \frac{1}{2} I_{rod} \dot{\theta}^2$$

(Kinetic energy of the system)

$$V = ~~m g r \cos \theta (1 - \sin \theta)~~ m g r (1 - \sin \theta) (\cos \theta - 1)$$

$$\begin{aligned} \mathcal{L} = T - V &= \frac{1}{2} m_r (\dot{X}^2 + 2 \dot{X} r \dot{\theta} \cos \theta + r^2 \dot{\theta}^2) + \frac{1}{2} m_c \dot{X}^2 + \frac{1}{2} I_r \dot{\theta}^2 \\ &\quad - m g r (1 - \sin \theta) (\cos \theta - 1) \end{aligned}$$

\dot{x}

$$\frac{\partial \mathcal{L}}{\partial \dot{x}} = m_r \dot{x} + m_r r \dot{\theta} \cos \theta + m_c \dot{x}$$

$$\frac{\partial \mathcal{L}}{\partial x} = 0$$

$$\Rightarrow \frac{d}{dt} \left(\frac{\partial \mathcal{L}}{\partial \dot{x}} \right) - \frac{\partial \mathcal{L}}{\partial x} = F$$

$$\Rightarrow m_r \ddot{x} + m_r r \ddot{\theta} \cos \theta - m_r r \dot{\theta}^2 \sin \theta + m_c \ddot{x} = F$$

~~$m_r \ddot{x} + m_r r \ddot{\theta} \cos \theta - m_r r \dot{\theta}^2 \sin \theta + m_c \ddot{x} = F$~~

$$\boxed{(m_r + m_c) \ddot{x} + m_r r (\ddot{\theta} \cos \theta - \dot{\theta}^2 \sin \theta) = F} \quad (1)$$

$$\dot{\theta} \frac{\partial \mathcal{L}}{\partial \dot{\theta}} = m_r \dot{x} r \cos \theta + m_r r^2 \dot{\theta} + I_r \dot{\theta}$$

$$\frac{\partial \mathcal{L}}{\partial \theta} = m_r g x \sin \theta - m_r g r \sin \theta$$

$$\Rightarrow m_r \dot{x} r \cos \theta - m_r \dot{x} r \dot{\theta} \sin \theta + m_r r^2 \ddot{\theta} + I_r \ddot{\theta} - m_r g r \sin \theta = 0$$

$$\boxed{m_r r (\dot{x} \cos \theta - \dot{x} \dot{\theta} \sin \theta) + (I_r + m_r r^2) \ddot{\theta} - m_r g r \sin \theta = 0} \quad (2)$$

Note x doesn't appear explicitly in the equations:
 $\therefore x$ is an ignorable coordinate.

Look for steady motion.

(i) all non-ignorable coordinates are constant

(ii) all ignorable coordinates' velocities are constant.

$$m r^2 \dot{\theta}^2 \sin \theta \cos \theta + m g r \sin \theta = 0$$

Steady motion

$$\rightarrow F=0 \quad \text{from eqn. (1)}$$

$$\rightarrow m g r \sin \theta = 0 \quad \Rightarrow \quad \theta = 0, \pi, \dots, n\pi,$$

$\theta = 0$ is the only allowable steady-motion in this system due to design requirement.

Linearize equation of motion about $\theta = 0$
 $\theta = \varepsilon(t) \quad \varepsilon \ll 1$

$$(m_r + m_c) \ddot{x} + m_r r \ddot{\varepsilon} = F \quad (1)$$

$$m_r r \ddot{x} + (I_r + m_r r^2) \ddot{\varepsilon} - m g r \varepsilon = 0 \quad (2)$$

Solve equation (1) for \ddot{x}

$$\rightarrow \ddot{x} = \frac{F - m_r r \ddot{\varepsilon}}{m_r + m_c}$$

$$\rightarrow \ddot{x} = \frac{F - m_r r \ddot{\varepsilon}}{(m_r + m_c)} \quad (3)$$

Substitute (3) into (2)

$$\Rightarrow m_r r \left(\frac{F - m_r r \ddot{\varepsilon}}{(m_r + m_c)} \right) + (I_r + m_r r^2) \ddot{\varepsilon} - m g r \varepsilon = 0$$

$$\Rightarrow \frac{m_r r}{(m_r + m_c)} F - \frac{m_r^2 r^2}{(m_r + m_c)} \ddot{\varepsilon} + (I_r + m_r r^2) \ddot{\varepsilon} - m g r \varepsilon = 0$$

$$\Rightarrow \frac{m_r r}{(m_r + m_c)} F + \left(\frac{m_r r^2 (m_r + m_c) + I_r (m_r + m_c) - m_r^2 r^2}{(m_r + m_c)} \right) \ddot{\varepsilon} - m g r \varepsilon = 0$$

(3)

$$\Rightarrow \frac{m_r r}{(m_r + m_c)} F + \left(\frac{m_r^2 r^2 + m_r m_c r^2 + I_r (m_r + m_c) \frac{m_r r^2}{(m_r + m_c)}}{(m_r + m_c)} \right) \ddot{\epsilon}$$

$$-m_r g r \epsilon = 0$$

$$\Rightarrow \left(\frac{m_r m_c r^2 + I_r (m_r + m_c)}{(m_r + m_c)} \right) \ddot{\epsilon} - \underbrace{m_r g r}_{> 0} \epsilon + \frac{m_r r F}{(m_r + m_c)} = 0$$

$F = F_0 \delta(\epsilon - \epsilon_0)$

if $F=0$

stability equation,

↑
Bang-Bang
type.

$$\Rightarrow c_1 \ddot{\epsilon} - c_2 \epsilon = 0$$

$$c_1 > 0 \quad \phi \quad c_2 > 0$$

$$\epsilon \sim e^{rt} \quad r^2 e^{rt} - e^{rt}$$

$$c_1 r^2 - c_2 = 0$$

$$r^2 - \frac{c_2}{c_1} = 0 \Rightarrow r^{\pm} = \pm \frac{c_2}{c_1}$$

We have 1 positive root $\left(r = \frac{c_2}{c_1} \right)$ so the system will become unstable as $t \rightarrow \infty$ if we don't use an appropriate forcing function.

NAME

DATE

INSTRUCTOR

COURSE

SHEET NO.

OF

Dynamics

i) Rand had a baseball book that says for maximum distance, one must hit the ball at an angle θ . What is the angle. How would drag affect this angle. (The book says 35° , why?)

ii)

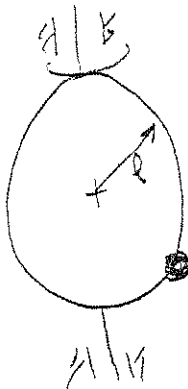

Bead on a hoop which is free to spin about axis shown

How many D.O.F.?

Find Equations of Motion

Is anything conserved?

iii)

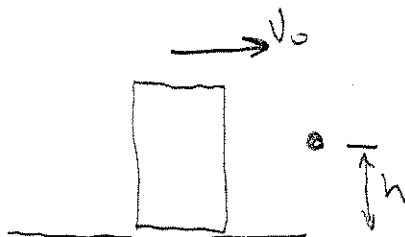

A cylinder slides into a horizontal rod at height h with velocity v_0 .

What should h be so the can does not tip over.

...Dr. Goyal runs an animated picture of a pencil dropping: The entire pencil falls at the same velocity but when one end hits first, the follow-up blow on the other end can occur at up to twice the speed. That's because the end that hits first bounces back at the same velocity, *thereby doubling the speed of the opposite end.* — Wall Street Journal, December 9, 1993

True or False? Why?

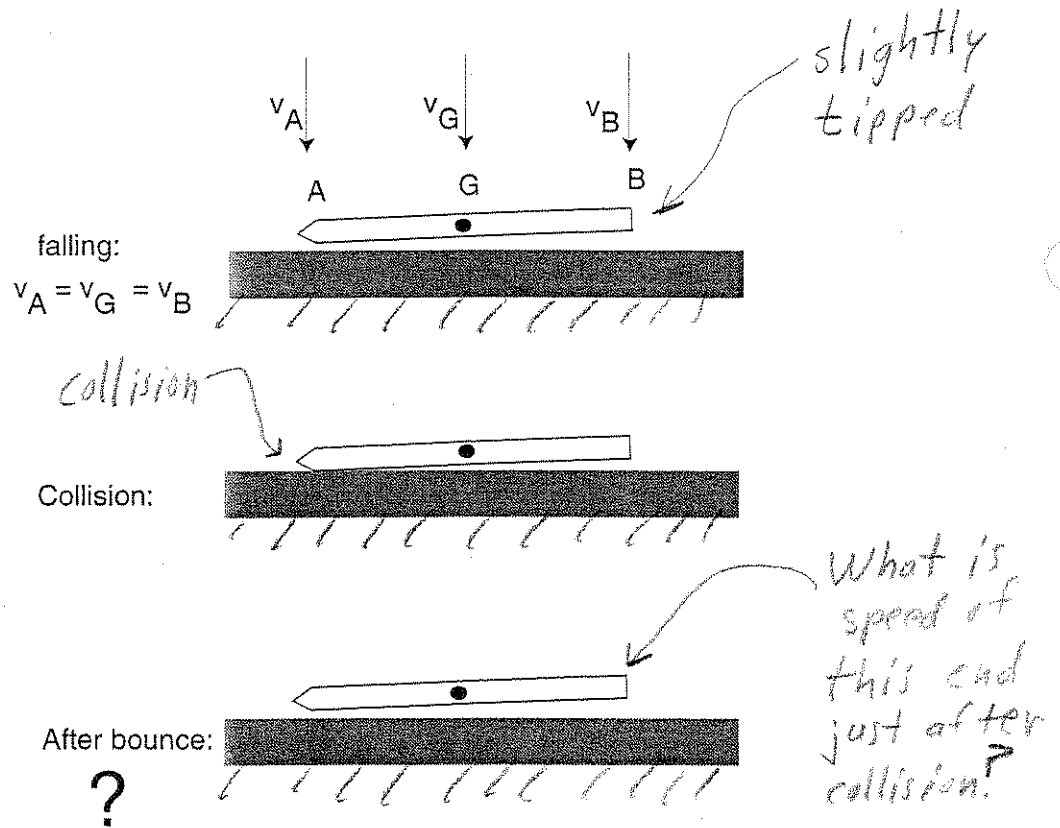

"follow up blow can occur at up to twice the speed"
 means
 speed of v_B can increase by up to a factor of 2.

Dynamic

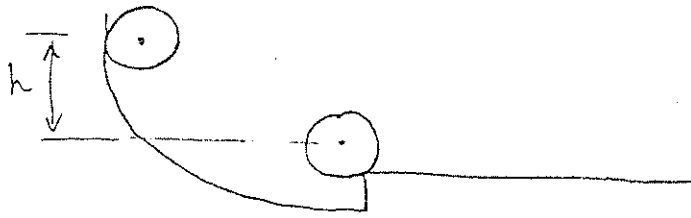

talk about how
you'd solve this
problem

- Describe what happens when you try
to turn a spinning wheel - (gyroscopes)

- ~~fun on a ramp~~

describe motion
how to solve?

II DYNAMICS

- ✓ 1. DERIVE THE EQUATIONS OF A PENDULUM
- ✓ 2. DERIVE THE EQUATIONS OF A DAMPED PENDULUM
- ✓ 3. DERIVE THE EQUATION OF A FALLING CHAIN
- ✓ 4. STABILITY OF AXES OF ROTATION OF A BOOK

Generally level of T&AM 203

B. Dynamics

1.

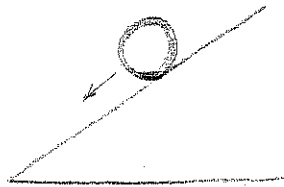

1.1 Solve the problem, assume

(i) with slippage (ii) without slippage

1.2 What are the restrictions ON

$$\tau = \frac{dt}{dt}?$$

1.3 Where is the above equation derived from?

Dynamics

- 1) Hockey puck impacts a wall
what is its direction, velocity
and spin when it leaves?
normal collision is elastic.

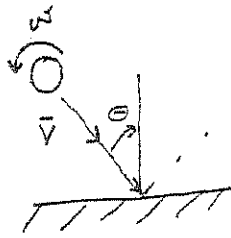

- 2) Bang on the end of a rod with a hammer. Listen to
the tone. What is the bar made of? How can
you tell.

2 - Dynamics

a - What is the equation for simple pendulum

b - Write down the equation motion for a pendulum
whose ^{length} varies with time.

c - Suppose you have a rope of constant mass, you lift
it from the table with constant F , neglect g , calculate
 v in time.

Topic -

Student - Tapesht

Dynamics:

- ③ Explain Foucault's Gyroscope

Q-Exam Questions

Jeffrey Nussbaum

Dynamics

Presentation- Dynamics of the spinning top

Questions essentially on talks:

Euler's equations - what are they, where do they come from, why use Euler angles instead of Euler equations?

What if top is not axi-symmetric? What if there is friction. Is conservation assumed or derived? Show how to derive.

Why doesn't a stabilizing gyro slow down?

Tunnel drilled through the earth. Describe motion (Simple harmonic, period = 24 minutes,)



Math

Why does $\dot{x} = \sqrt{x}$ have 2 solutions

$$\int_0^{\infty} \frac{1}{x^2+1} dx$$

Tell about contour integrals, Residue Theorem, Indented contours.

How do Runge-Kutta, Euler methods work? Error estimate?

How do you get from $I = \int_{t_1}^{t_2} f(x, \dot{x}, t) dt$ to Euler equation (Calculus of Variations)

Elasticity

What is a gauge factor? Can a strain gauge be used in dynamic problems?

Suppose $\underline{\sigma} = \text{constant}$ is the stress tensor. Is this OK?

What must be satisfied? Why? (Sym., Equil., $T_i = \sigma_{ij} n_j$)

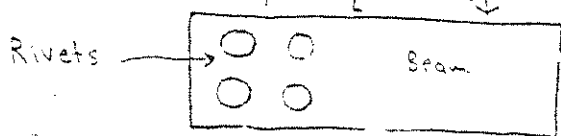

Find rivet loads, what if rivets are different sizes, what about friction?

2.

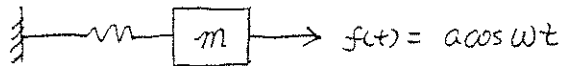

- 2.1. What does "resonance" means?
- 2.2. If resonance occurs, what does the response look like?
- 2.3. If ω is a little bit different from ω_c (natural frequency), what would the response look like?
- 2.4. If add a damper to the system, what is the relationship between the phase lag and the driving frequency ω ?

3.

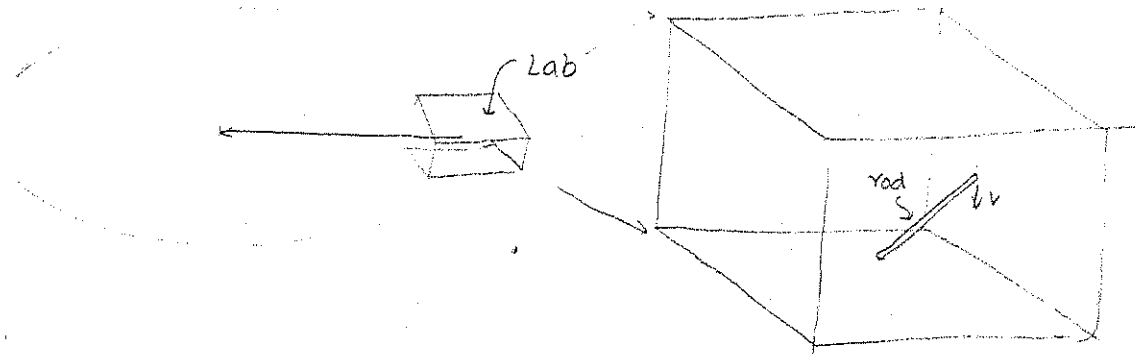

- 3.1. Does the rod have angular acceleration?
- 3.2. How to measure angular acceleration?
- 3.3. How to measure linear acceleration by using a force sensor?

4.) $\int_{-\pi}^{\pi} f(x) dx = 0$

$$\int_{-\pi}^{\pi} [f(x)]^2 dx = \int_{-\pi}^{\pi} [f'(x)]^2 dx$$

f is not the zero function

What are the restrictions on f ?

Use Fourier series

(Answer is $f(x) = A \cos x + B \sin x$ is only possibility)

Dynamics

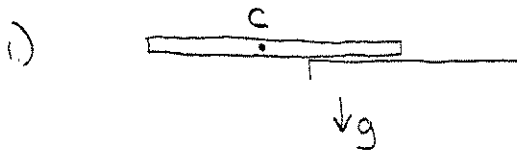

Ruler is released from position above. Initially, the point of the ruler touching the corner of the table sticks, but at some time it starts to slide.

Describe how you would set up this problem.

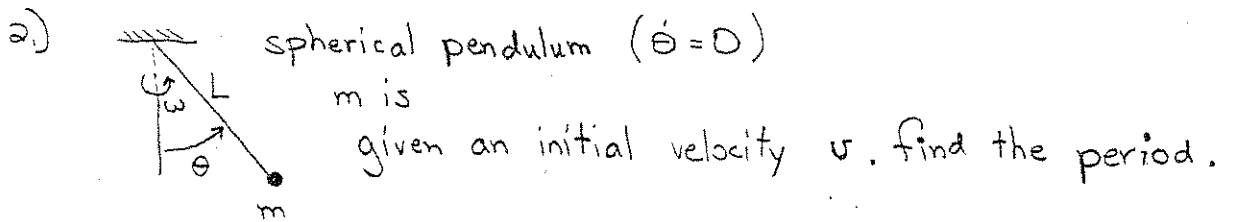

If the mass is given a slight disturbance ($\dot{\theta}$ no longer = 0) find the period.

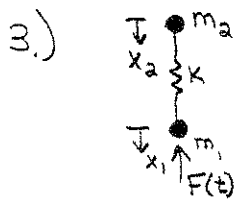

set up equations of motion.

Given (\ddot{x}_1, \ddot{x}_2) how would you find $F(t)$?

4.) What is the difference between Lagrange's Eqns. and Newton's Eqns. ?

December 1973

I. COLLISIONS OF RIGID BODIES.

Two bodies of mass m_1 and m_2 collide as shown in the figure.

At the moment of collision, they contact at point P with a common tangent plane and a normal, \vec{n} , to that plane. We are in general given:

$$\vec{v}_1, \vec{v}_2, \vec{\omega}_1, \vec{\omega}_2 \text{ before impact,}$$

and wish to determine:

$$\vec{v}'_1, \vec{v}'_2, \vec{\omega}'_1, \vec{\omega}'_2 \text{ after impact.}$$

The twelve unknown quantities (4 vectors) are related to the given quantities by the empirical law of collision and equations for impulsive motion:

$$\int_0^{\Delta t} \vec{F} dt = [m \vec{v}]_0^{\Delta t}$$

Linear momentum

$$\int_0^{\Delta t} \vec{M} dt = [\vec{H}]_0^{\Delta t}$$

Angular momentum

The twelve equations are:

(1) Law of Collisions - When two bodies collide, the values of the normal component of the relative velocity of the surfaces in contact at instants immediately after and immediately before the impact bear a definite ratio to each other; this ratio, denoted by $-e$, depends only on the material of which the bodies are composed (one eq.).

$$-e = \frac{\vec{v}'_{1p} \cdot \vec{n} - \vec{v}'_{2p} \cdot \vec{n}}{\vec{v}_{1p} \cdot \vec{n} - \vec{v}_{2p} \cdot \vec{n}}$$

where

$$\vec{v}_{1p} = \vec{v}_1 + \vec{\omega}_1 \times \vec{r}_{1p} \text{ etc.}$$

(2) Constancy of angular momentum of each body about the point of contact, P, because of zero moment about P (six eqs.).

$$\vec{L}_P = 0.$$

(3) Constancy of linear momentum of the system (two bodies) normal to the surface of contact because of equal and opposite normal impulses (one eq.)

$$(m_1 \vec{v}_1 + m_2 \vec{v}_2) \cdot \vec{n} = (m_1 \vec{v}'_1 + m_2 \vec{v}'_2) \cdot \vec{n}$$

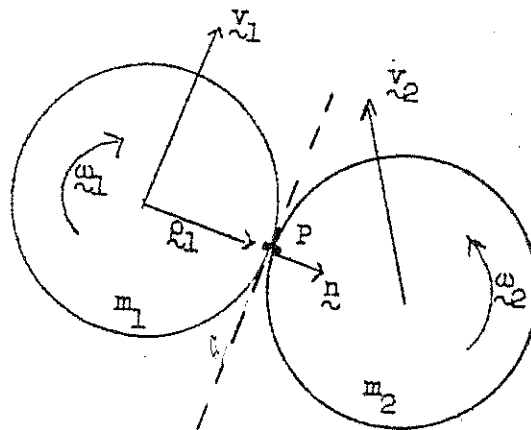

common tangent plane

- (4A) For smooth surfaces - No change in tangential components of the linear momentum for each body because of zero tangential forces (four eqs.)

$$\underline{n} \times (m\underline{v}' \times \underline{n}) - \underline{n} \times (m\underline{v} \times \underline{n}) = 0$$

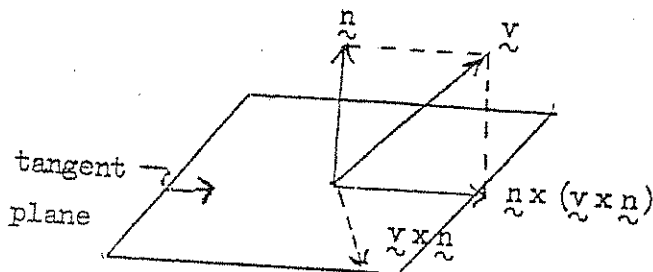

- (4B) For Rough Surfaces without Slipping at the Contact Point
- (i) Constancy of tangential components of the linear momentum of the system because of equal and opposite tangential impulses (two eqs.)

$$\underline{n} \times [(m_1 \underline{v}_1 + m_2 \underline{v}_2) \times \underline{n}] = \underline{n} \times [(m_1 \underline{v}_1' + m_2 \underline{v}_2') \times \underline{n}]$$

- (ii) Vanishing of the tangential components of the relative velocity of the two bodies after impact because of no slipping constraint (two eqs.)

$$\underline{n} \times [(\underline{v}'_{2p} - \underline{v}'_{1p}) \times \underline{n}] = 0.$$

- (4C) For Rough Surfaces with Slipping at the Contact Point

- (i) Same as (4Bi) (two eqs.)

- (ii) Change of the components of the linear momentum by the tangential impulse which equals, in magnitude to μ (coefficient of friction) times the normal impulse for each body (two eqs.)

$$|\underline{n} \times [m(\underline{v}' - \underline{v}) \times \underline{n}]| = \mu m (\underline{v}' - \underline{v}) \cdot \underline{n}$$

Note that there are two equations of the above form for each body; a total of 4 equations is obtainable. However, only two (for either body) are independent equations.

Discuss nature of angular momentum and relevant equations for a spacecraft. What are the equations? What about other formulations?

2

43 What constraints are there on the choice of reference frames for using the equations $\Sigma H = H$, $\Sigma F = ma$, ?

What is inertial reference frame? 2

44

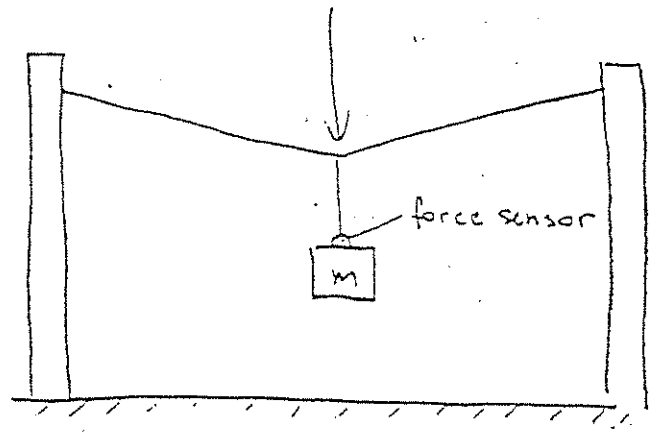

One pulls mass and released it.
 What is the nature of the motion?
 What is the equation of motion?
 When force has max. amplitude?
 How would you verify that the motion obeys the solution to the equation of motion?

45

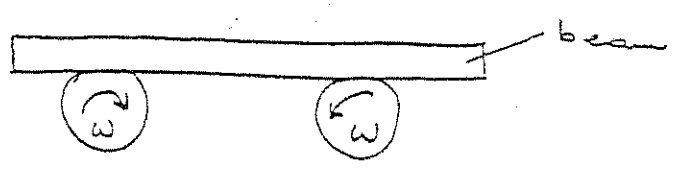

There is a friction between rollers and beam. What is the nature of the motion and eq. of

- 39) Rocket puck impacts a wall.
 What is its direction, velocity and spin when it leaves?
 Normal collision is elastic.

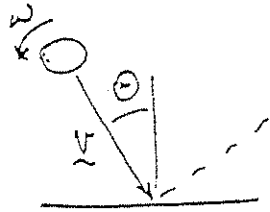

2

$$v'_n = -v_n$$

$$v'_t = v_t$$

$$\omega' = \omega$$

- 40) Bang on the end of a rod with a hammer.
 Listen to the tone. What is the bar made of?
 How can you tell?

$\frac{E}{S}$

1

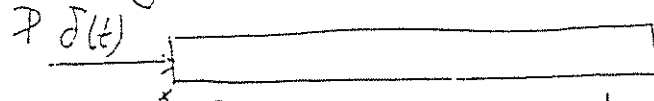

@ $x=0$: $u(x)=0$ $u(x,t) = f(L, c, \omega)$

@ $x=L$: $u'(x,L)=0$

- 41) Bullet strikes pendulum and is embedded.
 What is maximum angle θ of subsequent motion of the pendulum?

1

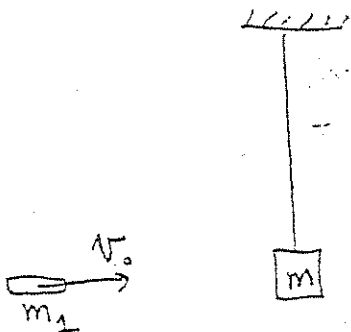

$$m_1 v = (m + m_1) v'$$

$$v' = \frac{m_1 v}{m + m_1}$$

$$\frac{m v'^2}{2} = mgR(1 - \cos\theta)$$

$$\cos\theta = 1 - \frac{v'^2}{2gR} = 1 - \left(\frac{m_1}{m + m_1} \right)^2 \frac{v^2}{2gR}$$

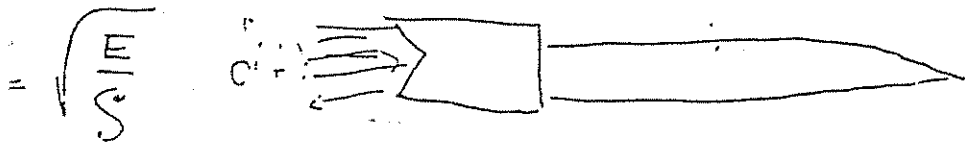

34 In order to study the vibrations of a beam, assume we model the beam as a linear - mass spring system subject to a time varying force \$F(t)\$.

\$F(t)\$ is taken to be large, so that the motion is essentially 1-D.

What is motion of the system for the cases:

(a) \$F(t) = F\delta(t)\$ (an impulse force)

(b) \$F(t) = \text{an arbitrary function of time}\$

(c) How do you apply B.C.?

Hints:

In (a) you need to consider balance of some quantity.

a) $m\dot{x}(0^+) - m\dot{x}(0^-) = F = \int_{-\infty}^{\infty} F\delta(t) dt$

$m\ddot{x} + kx = F\delta(t)$

rectangular

$x = A\cos\sqrt{\frac{k}{m}}t + B\sin\sqrt{\frac{k}{m}}t + \sqrt{\frac{m}{k}}F(t)\delta(t)$

$x(0) = 0 \Rightarrow A = 0$

A diagram of a mass \$m\$ on a spring with constant \$k\$. A force \$F(t)\$ is applied to the mass. The displacement is \$x\$.

35 A ~~square~~ plate rotates at a constant angular velocity about one of its diagonals.

What are reaction forces at supports A, B?

What is the pertinent formula

how would you go about deriving it?

If you didn't remember it?

$\omega = \omega \cos \theta$

$\dot{\theta} = \omega \sin \theta$

$\dot{\theta} = \omega \cos \theta$

$\dot{\theta} = \omega \sin \theta$

$\dot{\theta} = \omega \cos \theta$

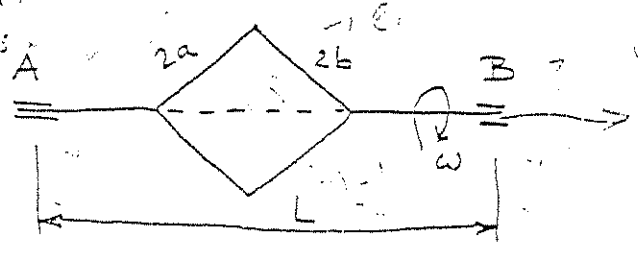

$M_C = \dots$

$\dots = \dots$

$\dots = \dots$

$\dots = \dots$

$F = ma \Rightarrow \dots = 0$

2

$\frac{d}{dt} \int_V \rho \mathbf{v} \cdot d\mathbf{V} = \int_V \rho \mathbf{f} \cdot d\mathbf{V} + \int_S \rho \mathbf{v} \cdot \mathbf{n} \cdot dA$

6) What is generalized force? ①

if we have non-conservative
 $\delta W = \sum_i F_i^{\text{nc}} \cdot \delta x_i$

7) Lagrangian equations!

$$\frac{d}{dt} \left(\frac{\partial L}{\partial \dot{q}_i} \right) - \frac{\partial L}{\partial q_i} = Q_i$$

$$\frac{d}{dt} \left(\frac{\partial T}{\partial \dot{q}_i} \right) - \frac{\partial T}{\partial q_i} = Q_i$$
①

if no gen'd force
 $\frac{d}{dt} \left(\frac{\partial L}{\partial \dot{q}_i} \right) - \frac{\partial L}{\partial q_i} = 0$

8) Water inside the hour glass. If we spin it, it forms a curve as it goes down. Find this curve as: $z(r)$.

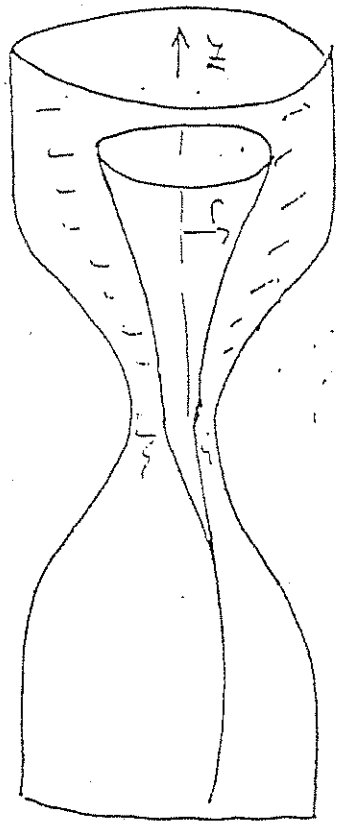

③

- a) Write a free body diagram for an surface element
- b) Force balances

↑ D ↓

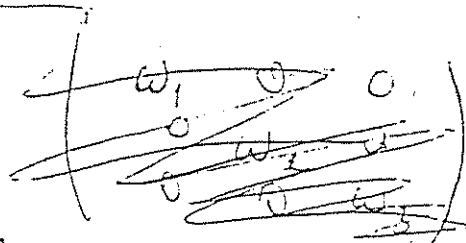

skew matrix

$$W = \begin{pmatrix} 0 & -\omega_3 & \omega_2 \\ \omega_3 & 0 & -\omega_1 \\ -\omega_2 & \omega_1 & 0 \end{pmatrix}$$

(6)

(29) Express angular velocity as a matrix (not vector)

~~ω_1~~ ~~ω_2~~ ~~ω_3~~ $\underline{W} \underline{v} = \underline{\omega} \times \underline{v}$

(30) What are restrictions on Euler Equations?
 - time dependent body-fixed coordinates
 difficult for inertial fixed observer.

(2)

(31) Drill a tunnel through the earth. How long does it take for a body to fall from one end to the other?
 Give the number for the time if the hole passes through the earth's center.

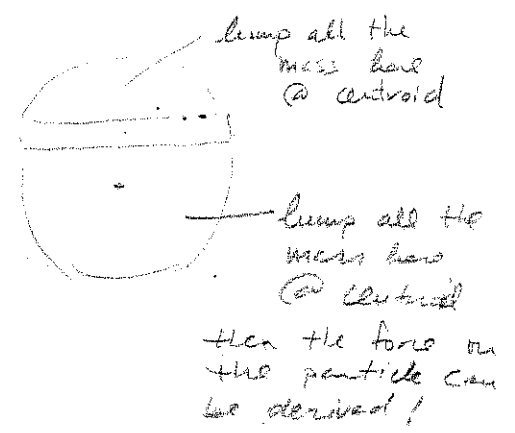
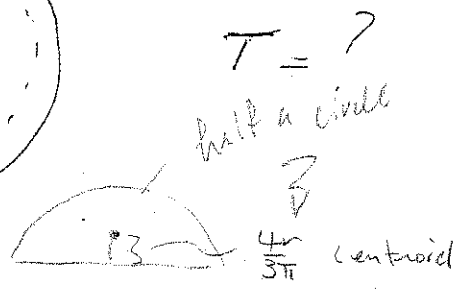
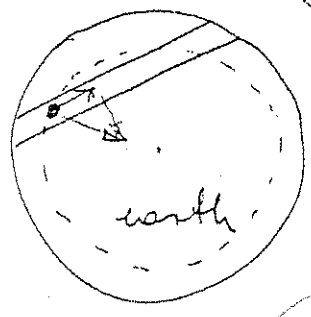

(32) Derive the equation of a falling chain.

(2)

(33) Stability of axes of rotation of a book.

(1)

Dynamics

1.) (Zehnder) A mass (M) is dropped on a beam.

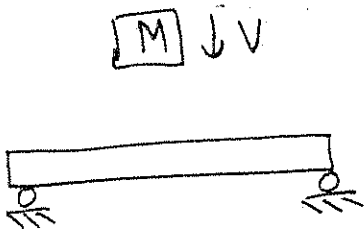

Modelled as:

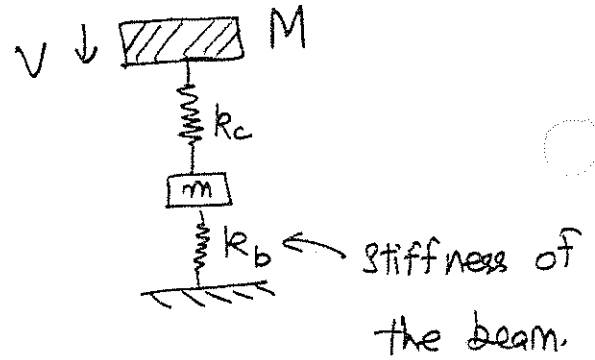

Obtain the equations of motion.

How would you get (m) & k_b .

2.) (Lance) Jet on a plate.

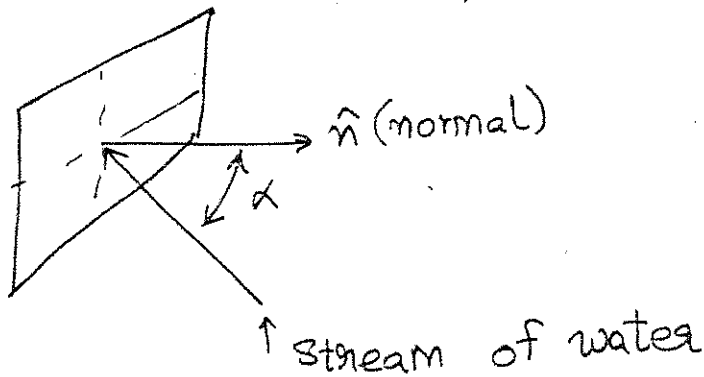

Formulate the problem.

What forces would be required?

To hold the plate in place?

3.) How do musical instruments work?

Discussed a lot on that.

Pick an instrument of your choice and explain it.

- (25) Describe the motion of a simple pendulum. Change the rigid swing-arm to a spring, how does this affect the system? What if the pendulum is moving in a fluid?

①

(26)

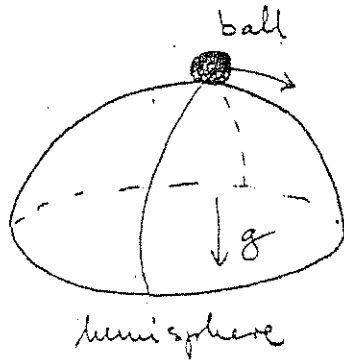

Describe the motion of the ball.

①

- (27) Explain Foucault's Gyroscope (Heally)

- (28) Derive a formula for escape velocity in terms of "known" quantities for

①

a) earth - satellite

②

b) Sun - earth - satellite system

$$\xi = \frac{m_s v^2}{2} - \frac{m_s m_{\text{earth}}}{r_{se}} - \frac{m_s m_{\text{sun}}}{r_{ss}} = 0 \quad \rightarrow \text{solve for } v$$

known: g , year, 24 hours, distances, no masses, G .

Kepler's law ②



58

Euler's equations . Dynamics of the spinning top.

- a) What are they ?
- b) Where do they come from ?
- c) Why use Euler angles, instead of Euler equations ? — because ω is not constant to the time t of axis of gyration
- d) What if top is not axis-symmetric ? of axis of gyration
- e) What if there is a friction ?

11

- f) Is conservation assumed or derived ? derived
- g) Show how to derive !
- h) Why doesn't a stabilizing gyro slow down ?

59

In the game of bowling a player throws the ball on the surface which slides upto certain distance and then starts to roll.

2

Derive an expression for the time taken before rolling starts, given initial velocity v_0 .

Does the result depends on the geometry or mass of the object if v_0 is the same ?

$$t = \frac{v_0}{\mu g (1 - \frac{m}{M})}$$

$$- \mu g t = - \mu \frac{m}{M} g t - v_0$$

53

Puls hammer? Discus!
 How to measure the force?
 Equation of the mechanism inside
 the hammer?

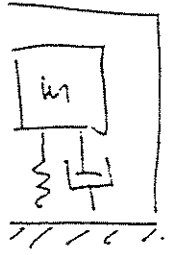

2

$$m\ddot{x} + kx = F(t)$$

54

What is constraint?

holonomic constraint
 non-holonomic constraint

1

55

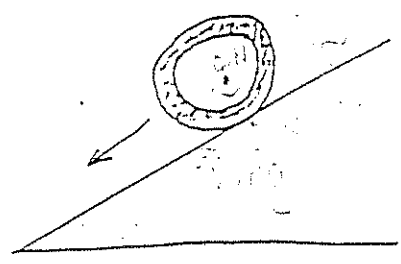

$$L = \frac{1}{2} m \dot{x}^2 + \frac{1}{2} I \dot{\theta}^2$$

$$I = \frac{1}{2} m r^2$$

- a) Solve the problem:
- (i) with slippage
 - (ii) without slippage

b) What are restrictions on $T = \frac{dL}{dt}$

c) Where is the above equation derived from?



$$N = mg \cos \theta$$

$$f = \mu N$$

$$F = ma$$

$$I \ddot{\theta} = m \ddot{x} r = m a r$$

$$m \ddot{x} = m g \sin \theta - f$$

Find equations of motion
for this system. Use any
coordinates or method you like.

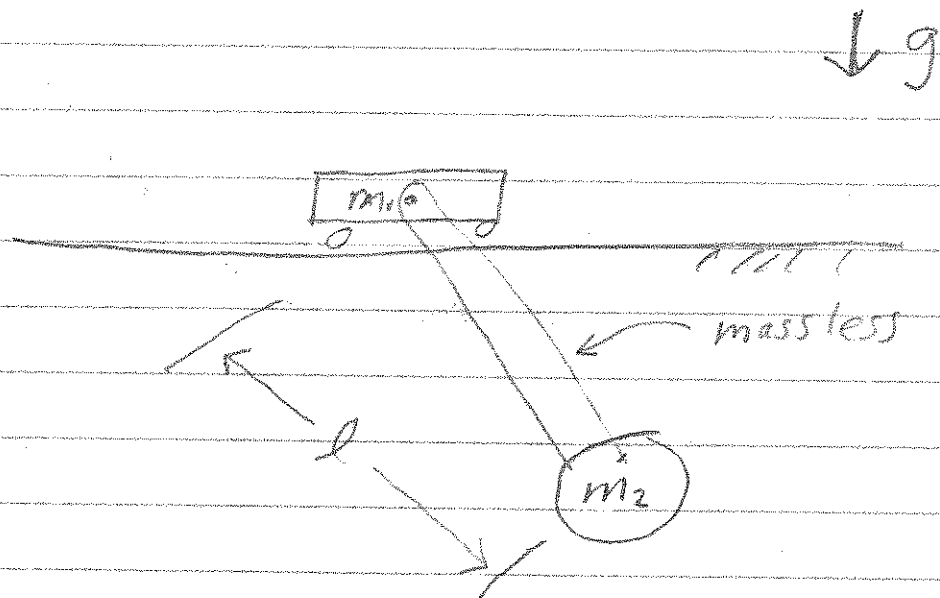

Dynamics

4) Suppose there's a chair ^{How can one} find the principal moment
of inertia of the chair?

0

0

1. Dynamics.

Jan 21.

Examinee G Zhang

Questions: 1) A rule initially lies on a table supported by hand. then withdraw the hand. ~~Describe~~ Derive equations of motion.

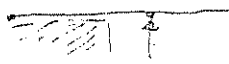

What is the relationship between the angular velocity $\dot{\theta}$ and the velocity of mass center?

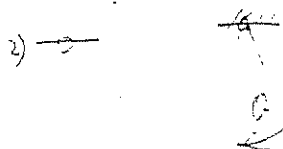

Derive the velocity and acceleration.



given constant $\dot{\theta}$, find θ .

How many method can you use

4). There ~~is~~ was an experimental set-up. An oscilloscope and a hammer attached to it. Prof Sachse gives a small blow to the cable with hammer and asks to explain what the pulse on the screen indicates?

What is inside the hammer?

Write down the equation for the mechanics inside the hammer. Explain how to measure the force?

5). What is the difference between Newton's method ~~and~~ Lagrange ~~method~~ method. What is constraint?

Sample Dynamics Questions (Not from any exam)

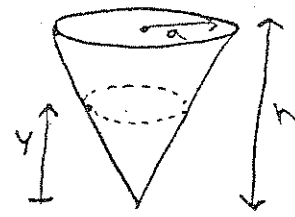
1.  A particle travels in a circular path on the inside of a cone. Find its speed v as a function of y .

$r = ky$
 $r = a \frac{y}{h}$

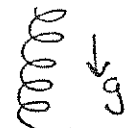
2.  A particle travels along a helical spring until it reaches the end of the spring and falls off. What is its trajectory?

3. State Newton's 3 laws, D'Alembert's Principle.

4. Find the altitude of a geosynchronous orbit.

5. A single propeller airplane is making a right turn. The propeller is spinning counter-clockwise as viewed from behind. What is the gyroscopic effect? How could you compensate on a multi-engine craft.

Answers: Nose rises. Have the propellers spin in opposite directions

6. Explain the 5 term acceleration formula. What is the Coriolis acceleration?

7. A motor is sitting on a turntable. It spins at ω_1 , and its shaft is horizontal. The turntable spins at ω_2 . Find $\underline{\omega}$, $\underline{\alpha}$ of the shaft.

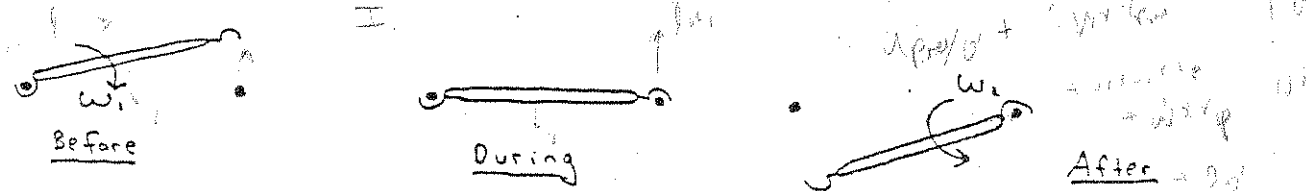
8.  Before, During, After

Show that $\omega_2 = \frac{1}{2} \omega_1$. Rigid rod, $\bar{I} = \frac{1}{3} m L^2$, $I_{end} = \frac{1}{2} m L^2$

$$I \omega_1^2 = \frac{1}{3} m L^2 \omega_1^2 = \frac{1}{2} m L^2 \omega_2^2 \Rightarrow \omega_2 = \frac{1}{2} \omega_1$$