

CHAPTER 13

Circular motion

After movement on straight-lines the second important special case of motion is rotation on a circular path. Polar coordinates and base vectors are introduced in this simplest possible context. The key new idea is that not just coordinates, but base vectors, can change with time. The primary applications are pendulums, gear trains, and rotationally accelerating motors or brakes.

Contents

We covered the special case of straight-line motion in the previous chapter. But an unconstrained particle, such as a thrown ball, generally moves on a curved path as pushed by gravity and aerodynamic forces. Also, when a rigid object moves, it translates and rotates while the points on the object move on complicated curved paths. Now we consider the archetypal curved motion, motion on along a circular path. Circular motion deserves special attention because

- the most common connection between moving parts on a machine is with a bearing (or hinge or axle) (*Fig. 13.1*), if the axle on one part is fixed then all points on the part move in circles;
- circular motion is the simplest case of curved-path motion;
- circular motion provides a simple way to introduce time-varying base vectors;
- circular motion includes most of the conceptual ingredients of more general curved motions;
- at least in 2 dimensions, the only way two particles on one rigid object can move relative to each other is by circular motion (no matter how the object is moving); and
- circular motion is the simplest case with which to introduce two important rigid-object concepts:
 - angular velocity, and
 - moment of inertia.

Many useful calculations can be made by approximating the motion of particles as circular. For example, the motions of points on a jet engine's turbine blade, a car engine's crank shaft, a car's wheel, a windmill's propeller, the earth spinning about its axis, a clock pendulum or watch balance wheel, all the points on a bicycle when it is going around a corner, a satellite orbiting the earth or a spinning satellite going around its spin axis, might all be approximately described as having circular motion about some appropriate point or axis.

This chapter concerns only motion in two dimensions. The first two sections consider the kinematics and mechanics of a single particle going in circles. The later sections concern the kinematics and mechanics of rigid objects. More advanced chapter ?? discusses circular motion, which is always planar, in a three-dimensional context.

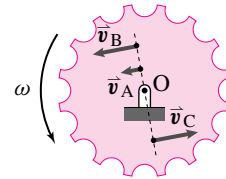

Figure 13.1: All the points on a gear move in circles, assuming the axle is not translating.

Filename:figure4-1a



Figure 13.2: All points on a flywheel move in circles. The points further from the center move faster, so they move further while the camera shutter is open, so they show a bigger motion blur (the constant-thickness spokes look fatter near the rim).

Filename:Flywheels0072

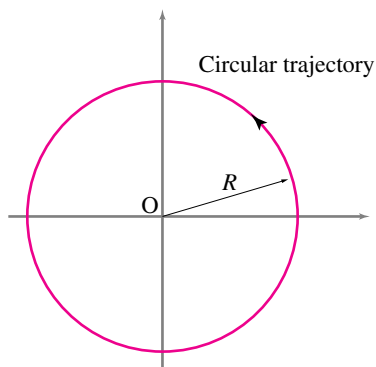

Figure 13.3: Trajectory of particle for circular motion.

Filename: tfigure1-i

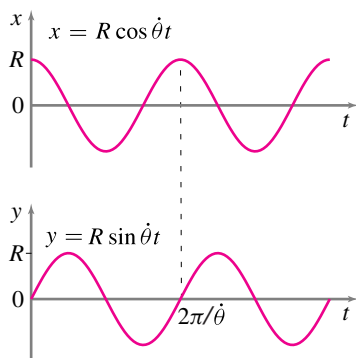

Figure 13.4: Plots of x versus t and y versus t for a particle going in a circle of radius R at constant rate. For simplicity we assumed constant $\dot{\theta}$ with $\theta = \dot{\theta}t$. So both x and y vary as sinusoidal functions of time: $x = R \cos(\dot{\theta}t)$ and $y = R \sin(\dot{\theta}t)$.

Filename: tfigure1-h

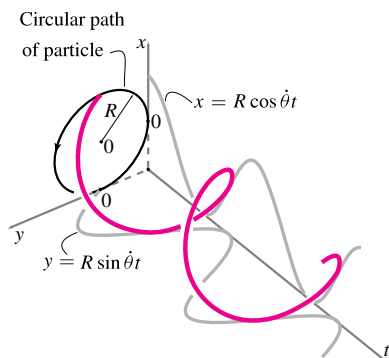

Figure 13.5: Plot of x and y versus time for a particle going in circles at constant rate. x versus t is a cosine curve, y versus t is a sine curve. Together they make up the 3D helix.

Filename: tfigure1-j

Mechanics of circular motion

For the systems in this chapter, for every system we show in a free body diagram we have, as always,

$$\text{linear momentum balance, } \sum \vec{F}_i = \dot{\vec{L}}$$

$$\text{angular momentum balance, } \sum \vec{M}_{i/C} = \dot{\vec{H}}_{/C},$$

$$\text{and power balance: } P = \dot{E}_K + \dot{E}_P + \dot{E}_{\text{int}}.$$

Because you already know how to work with forces and moments (the left sides of the top two equations), the primary new skill in this chapter is the evaluation of $\dot{\vec{L}}$, $\dot{\vec{H}}_{/C}$, and \dot{E}_K for a rotating particle or rigid object. That is, you need to understand the position, velocity and acceleration of points moving in circles. The rest of the skills used are universal, for example solving algebraic or differential equations, plotting, etc.

13.1 Kinematics of a particle in planar circular motion

This section concerns the position, velocity and accelerations of one point going in circles. The essence of the content here is this:

If \hat{e}_r is a unit vector in the plane that is rotating counter-clockwise (CCW) at a rate of $\dot{\theta}$ its rate of change is where \hat{e}_θ is a unit vector given by rotating \hat{e}_r 90° CCW.

If you learn this idea inside and out then either you will have picked up all the other key facts on the way, or you will be able to learn them in a flash.

Circular motion

The position of a particle going in circles around the origin on the xy plane is

$$\vec{r} = R \cos \theta \hat{i} + R \sin \theta \hat{j},$$

with the radius R a constant. Or, in terms of components,

$$x = R \cos \theta \quad \text{and} \quad y = R \sin \theta.$$

A natural graphical representation of this motion is a drawing of a circle (Fig. 13.3). Unfortunately, a picture of the circular trajectory doesn't give any information about the speed of the particle. A plot

of a particle moving in circles slowly looks just like a plot of a particle moving quickly.

To get a sense of how position changes in time one can plot the functions $x(t)$ and $y(t)$ (Fig. 13.4). Unfortunately this figure only indirectly conveys that the particle is going in circles.

If you want to see both the trajectory and the time history of both variables one can make a 3-D plot of xy position versus time (Fig. 13.4). The shadows of this helix on the three coordinate planes are the three graphs just discussed. How you make such a graph with a computer depends your available software.

Finally, rather than representing time as a spatial coordinate, one can represent time with time itself. How? Make an animated movie showing a particle on the xy plane as it moves. Move your finger around in circles on the table. That's it. How do you make all these plots? Using a calculator or computer you can evaluate x and y for a range of values of t . Then, using pencil and paper, a plotting calculator, or a computer, plot x vs t , y vs t , and y vs x . For animations plot x and y over and over again for a sequence of values of t , and show these on your screen at a sequence of times.

Polar coordinates R and θ and unit vectors \hat{e}_R and \hat{e}_θ

Especially for circular motion, it is convenient to represent position, velocity and acceleration with polar rather than rectangular coordinates. With polar coordinates we also use polar base vectors which, unlike \hat{i} and \hat{j} , rotate as the particle goes around. Let's redraw Fig. 13.3 and show the unit base vectors \hat{e}_R ('e R') and \hat{e}_θ ('e theta'). The radial unit vector \hat{e}_R is directed from the center of the circle towards the point of interest and the transverse vector \hat{e}_θ , perpendicular to \hat{e}_R , is tangent to the circle at that point in the direction of increasing θ . As the particle goes around, its \hat{e}_R and \hat{e}_θ unit vectors change accordingly. Two different particles both going in circles with the same center at the same rate each have their own \hat{e}_R and \hat{e}_θ vectors. We will make frequent use the polar coordinate unit vectors \hat{e}_R and \hat{e}_θ .

The velocity and acceleration of a point going in circles, using polar coordinates

In dynamics we are interested in velocity and acceleration so need to know how to represent these in polar coordinates. First, observe that the position of the particle is (see figure 13.6)

$$\vec{R} = R\hat{e}_R. \quad (13.1)$$

That is, the position vector is the distance from the origin times a unit

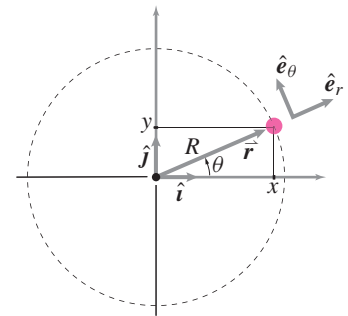

Figure 13.6: The position vector \vec{r} of the particle relative to the center of the circle is \vec{r} (or \vec{R}) which is both $\vec{r} = x\hat{i} + y\hat{j}$ and $\vec{r} = R\hat{e}_R$ (or $r\hat{e}_r$).

\vec{r} makes an angle θ measured counter-clockwise from the positive x -axis. The unit vectors \hat{e}_R and \hat{e}_θ are in the radial and tangential directions, the directions of increasing R and increasing θ .

Filename:figure4-4

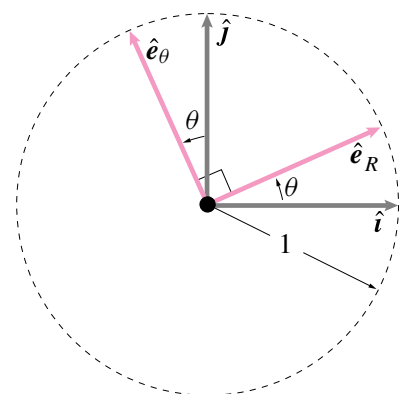

Figure 13.7: You can think of the unit vectors \hat{e}_r and \hat{e}_θ as the set \hat{i} and \hat{j} rotated counter-clockwise by the angle θ .

Filename:figure4-5reduced

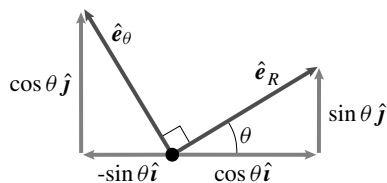

Figure 13.8: Projections of \hat{e}_r and \hat{e}_θ in the x and y directions. From this picture you can immediately extract that

$$\hat{e}_r = \cos \theta \hat{i} + \sin \theta \hat{j} \text{ and that}$$

$$\hat{e}_\theta = -\sin \theta \hat{i} + \cos \theta \hat{j}.$$

A similar picture showing the projections of \hat{i} and \hat{j} in the \hat{e}_r and \hat{e}_θ directions would show that

$$\hat{i} = \cos \theta \hat{e}_r - \sin \theta \hat{e}_\theta \text{ and that}$$

$$\hat{e}_\theta = \sin \theta \hat{e}_r + \cos \theta \hat{e}_\theta.$$

Filename:figure4-5a

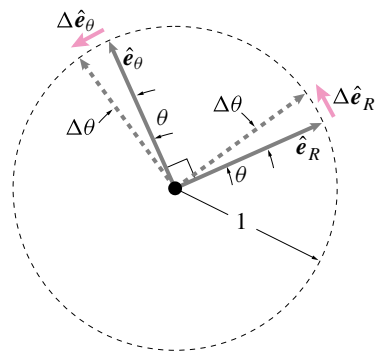

Figure 13.9: A close up view of the unit vectors \hat{e}_r and \hat{e}_θ . They make an angle θ with the positive x and y -axis, respectively. As the particle advances an amount $\Delta\theta$ both \hat{e}_r and \hat{e}_θ change. In particular, for small $\Delta\theta$, $\Delta\hat{e}_r$ is approximately in the \hat{e}_θ direction and $\Delta\hat{e}_\theta$ is approximately in the $-\hat{e}_r$ direction.

Filename:figure4-5

vector in the direction of the particle's position. Given the position, it is just a matter of *careful* differentiation to find velocity and acceleration. Here is one of many possible ways to derive the polar-coordinate expressions for velocity and acceleration. First, velocity is the time derivative of position, so

$$\vec{v} = \frac{d}{dt} \vec{R} = \frac{d}{dt} (R \hat{e}_r) = \underbrace{\dot{R}}_0 \hat{e}_r + R \dot{\hat{e}}_r. \quad (13.2)$$

Because a circle has constant radius R , \dot{R} is zero. But what is $\dot{\hat{e}}_r$, the rate of change of \hat{e}_r with respect to time?

Derivatives of \hat{e}_r and of \hat{e}_θ

To find the velocity in polar coordinates we were just confronted with the problem of finding the rate of change of the unit vector \hat{e}_r .

Method 1: One way to find $d\hat{e}_r/dt = \dot{\hat{e}}_r$ uses the geometry of figure 13.9 and the informal calculus of finite differences (represented by Δ). $\Delta\hat{e}_r$ is evidently (about) in the direction \hat{e}_θ and has magnitude $\Delta\theta$ so $\Delta\hat{e}_r \approx (\Delta\theta)\hat{e}_\theta$. Dividing by Δt , we have $\Delta\hat{e}_r/\Delta t \approx (\Delta\theta/\Delta t)\hat{e}_\theta$. So, using this sloppy calculus, we get $\dot{\hat{e}}_r = \dot{\theta}\hat{e}_\theta$. Similarly, and we will need this shortly, we could get $\dot{\hat{e}}_\theta = -\dot{\theta}\hat{e}_r$.

Method 2 This method is a little less geometric and a little more algebraic. We start with the decomposition of \hat{e}_r and \hat{e}_θ into cartesian coordinates. These decompositions are found by looking at the projections of \hat{e}_r and \hat{e}_θ in the x and y -directions (see figure 13.8).

$$\begin{aligned} \hat{e}_r &= \cos \theta \hat{i} + \sin \theta \hat{j} \\ \hat{e}_\theta &= -\sin \theta \hat{i} + \cos \theta \hat{j} \end{aligned} \quad (13.3)$$

We can find $\dot{\hat{e}}_r$ by differentiating, taking into account that θ is changing with time but that the unit vectors \hat{i} and \hat{j} are fixed (so they don't change with time).

$$\begin{aligned} \dot{\hat{e}}_r &= \frac{d}{dt} (\cos \theta \hat{i} + \sin \theta \hat{j}) = -\dot{\theta} \sin \theta \hat{i} + \dot{\theta} \cos \theta \hat{j} = \dot{\theta} \hat{e}_\theta \\ \dot{\hat{e}}_\theta &= \frac{d}{dt} (-\sin \theta \hat{i} + \cos \theta \hat{j}) = -\dot{\theta} \hat{e}_r \end{aligned}$$

We had to use the chain rule, that is

$$\frac{d \sin \theta(t)}{dt} = \frac{d \sin \theta}{d\theta} \frac{d\theta(t)}{dt} = \dot{\theta} \cos \theta.$$

Now, two different ways, we know

$$\dot{\hat{e}}_R = \dot{\theta} \hat{e}_\theta \quad \text{and} \quad \dot{\hat{e}}_\theta = -\dot{\theta} \hat{e}_R. \quad (13.4)$$

Continuing the quest for velocity

Now that we know how \hat{e}_R changes in time we can continue our quest for \vec{v} . Continuing from *eqn.* (13.2) we now have

$$\vec{v} = \dot{\vec{R}} = R \dot{\hat{e}}_R = R \dot{\theta} \hat{e}_\theta. \quad (13.5)$$

Similarly we can find the acceleration \vec{a} by differentiating once again,

$$\vec{a} = \dot{\vec{v}} = \frac{d}{dt}(R \dot{\theta} \hat{e}_\theta) = \underbrace{\dot{R} \dot{\theta} \hat{e}_\theta}_0 + R \ddot{\theta} \hat{e}_\theta + R \dot{\theta} \dot{\hat{e}}_\theta \quad (13.6)$$

The first term on the right hand side is zero because \dot{R} is 0 for circular motion. The third term is evaluated using the formula we just found for the rate of change of \hat{e}_θ : $\dot{\hat{e}}_\theta = -\dot{\theta} \hat{e}_R$. So, using that $\vec{R} = R \hat{e}_R$,

$$\vec{a} = -\dot{\theta}^2 \vec{R} + R \ddot{\theta} \hat{e}_\theta. \quad (13.7)$$

The velocity \vec{v} and acceleration \vec{a} for a particle going in circles at constant rate are shown in *Fig.* 13.10.

Example: A person standing on the earth's equator

A person standing on the equator has velocity

$$\begin{aligned} \vec{v} = \dot{\theta} R \hat{e}_\theta &\approx \left(\frac{2\pi \text{ rad}}{24 \text{ hr}} \right) 4000 \text{ mi} \hat{e}_\theta \\ &\approx 1050 \text{ mph} \hat{e}_\theta \approx 1535 \text{ ft/s} \hat{e}_\theta \end{aligned}$$

and acceleration

$$\begin{aligned} \vec{a} = -\dot{\theta}^2 R \hat{e}_R &\approx -\left(\frac{2\pi \text{ rad}}{24 \text{ hr}} \right)^2 4000 \text{ mi} \hat{e}_R \\ &\approx -274 \text{ mi/hr}^2 \hat{e}_R \approx -0.11 \text{ ft/s}^2 \hat{e}_R. \end{aligned}$$

The velocity of a person standing on the equator, due to the earth's rotation, is about 1000 mph tangent to the earth. Her acceleration is about $0.11 \text{ ft/s}^2 \approx 0.03 \text{ m/s}^2$ towards the center of the earth, about 1/300 of g , about 1/300 the acceleration of an object in near-earth-surface frictionless free-fall.

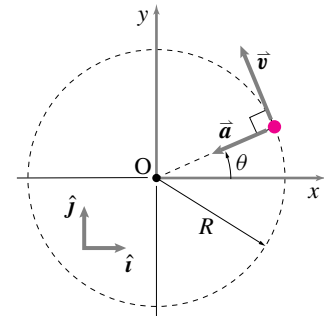

Figure 13.10: The directions of velocity \vec{v} and acceleration \vec{a} are shown for a particle going in circles at *constant* rate. The velocity is tangent to the circle and the acceleration is directed towards the center of the circle.

Filename:figure4-6

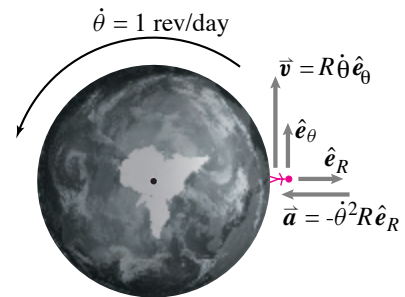

Figure 13.11:

Filename:figure4-1-example1

Alternate expressions for the velocity and acceleration formulas

Note that we can define a scalar velocity $v = R\dot{\theta}$. We informally call this scalar the speed even though it can be positive or negative. So

$$\vec{v} = R\dot{\theta}\hat{e}_\theta = v\hat{e}_\theta.$$

Similarly the acceleration is

$$\vec{a} = -R\dot{\theta}^2\hat{e}_R + R\ddot{\theta}\hat{e}_\theta = -\frac{v^2}{R}\hat{e}_R + \dot{v}\hat{e}_\theta.$$

① **Caution:** Note that the rate of change of speed is not the magnitude of the acceleration: $\dot{v} \neq |\vec{a}|$ or in other words: $\frac{d}{dt}|\vec{v}| \neq |\frac{d}{dt}\vec{v}|$. Consider the case of a car driving in circles at constant rate. Its rate of change of speed is zero, yet it has an acceleration.

where \dot{v} is the rate of change of tangential speed^①. Thus the acceleration is made of two terms. One proportional to the speed squared and directed towards the center of the circle, and one proportional to the rate of change of speed and directed tangent to the circle.

Why, intuitively, is the centripetal acceleration, proportional to the speed *squared*? Well, the acceleration is the change in the velocity vector per unit time. If the speed is twice as big than the velocity is twice as big. And, for a given radius, the angle it rotates per unit time is twice as big. Thus there are two effects, the size of the velocity vector which rotates and the rate at which it rotates. Hence the v^2 .

13.1 THEORY

The motion quantities

We can use our results for velocity and acceleration to better evaluate the momenta and energy quantities. These results will allow us to do mechanics problems associated with circular motion. For one particle in circular motion.

$$\begin{aligned} \vec{L} &= \vec{v}m = R\dot{\theta}\hat{e}_\theta m, \\ \dot{\vec{L}} &= \vec{a}m = (-\dot{\theta}^2\vec{R} + R\ddot{\theta}\hat{e}_\theta)m, \\ \vec{H}_{/O} &= \vec{r}_{/O} \times \vec{v}m = R^2\dot{\theta}m\hat{k}, \\ \dot{\vec{H}}_{/O} &= \vec{r}_{/O} \times \vec{a}m = R^2\ddot{\theta}m\hat{k}, \\ E_K &= \frac{1}{2}v^2m = \frac{1}{2}R^2\dot{\theta}^2m, \quad \text{and} \\ \dot{E}_K &= \vec{v} \cdot \vec{a}m = mR^2\dot{\theta}\ddot{\theta} \end{aligned}$$

We have used the fact that $\hat{e}_R \times \hat{e}_\theta = \hat{k}$ which can be

verified with the right hand rule definition of the cross product or using the Cartesian representation of the polar base vectors.

SAMPLE 13.1 The velocity vector in circular motion. A particle executes circular motion in the xy plane with constant speed $v = 5$ m/s. At $t = 0$ the particle is at $\theta = 0$. Given that the radius of the circular orbit is 2.5 m, find the velocity of the particle at $t = 2$ sec.

Solution It is given that

$$\begin{aligned} R &= 2.5 \text{ m} \\ v &= \text{constant} = 5 \text{ m/s} \\ \theta(t = 0) &= 0. \end{aligned}$$

The velocity of a particle in constant-rate circular motion is:

$$\begin{aligned} \vec{v} &= R\dot{\theta}\hat{e}_\theta \\ \text{where } \hat{e}_\theta &= -\sin\theta\hat{i} + \cos\theta\hat{j}. \end{aligned}$$

Since R is constant and $v = |\vec{v}| = R\dot{\theta}$ is constant,

$$\dot{\theta} = \frac{v}{R} = \frac{5 \text{ m/s}}{2.5 \text{ m}} = 2 \text{ rad/s}$$

is also constant. Thus,

$$\vec{v}(t = 2 \text{ s}) = \underbrace{R\dot{\theta}}_v \hat{e}_\theta \Big|_{t=2\text{s}} = 5 \text{ m/s } \hat{e}_\theta(t = 2 \text{ s}).$$

Clearly, we need to find \hat{e}_θ at $t = 2$ sec.

$$\begin{aligned} \text{Now } \dot{\theta} &= \frac{d\theta}{dt} = 2 \text{ rad/s} \\ \Rightarrow \int_0^\theta d\theta &= \int_0^{2\text{s}} 2 \text{ rad/s } dt \\ \Rightarrow \theta &= (2 \text{ rad/s}) t \Big|_0^{2\text{s}} \\ &= 2 \text{ rad/s} \cdot 2 \text{ s} \\ &= 4 \text{ rad}. \end{aligned}$$

Therefore,

$$\begin{aligned} \hat{e}_\theta &= -\sin 4\hat{i} + \cos 4\hat{j} \\ &= 0.76\hat{i} - 0.65\hat{j}, \end{aligned}$$

and

$$\begin{aligned} \vec{v}(2 \text{ s}) &= 5 \text{ m/s}(0.76\hat{i} - 0.65\hat{j}) \\ &= (3.78\hat{i} - 3.27\hat{j}) \text{ m/s}. \end{aligned}$$

$$\boxed{\vec{v} = (3.78\hat{i} - 3.27\hat{j}) \text{ m/s}}$$

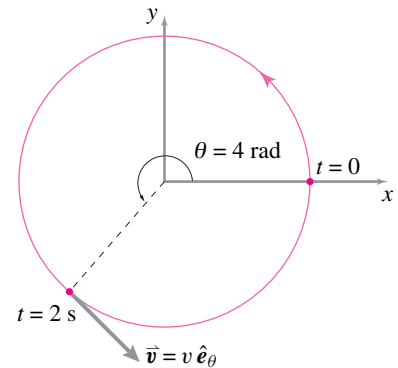

Figure 13.12: The velocity vector \vec{v} at $t = 2$ s.

Filename:fig4-1-DH

SAMPLE 13.2 Basic kinematics: A point mass executes circular motion with angular acceleration $\ddot{\theta} = 5 \text{ rad/s}^2$. The radius of the circular path is 0.25 m. If the mass starts from rest at $\theta = 0^\circ$, find and draw

1. the velocity of the mass at $\theta = 0^\circ, 30^\circ, 90^\circ$, and 210° ,
2. the acceleration of the mass at $\theta = 0^\circ, 30^\circ, 90^\circ$, and 210° .

Solution We are given, $\ddot{\theta} = 5 \text{ rad/s}^2$, and $R = 0.25 \text{ m}$.

1. The velocity \vec{v} in circular (constant or non-constant rate) motion is given by:

$$\vec{v} = R\dot{\theta}\hat{e}_\theta.$$

So, to find the velocity at different positions we need $\dot{\theta}$ at those positions. Here the angular acceleration is constant, i.e., $\ddot{\theta} = 5 \text{ rad/s}^2$. Therefore, we can use the formula ②

$$\dot{\theta}^2 = \dot{\theta}_0^2 + 2\ddot{\theta}\theta$$

to find the angular speed $\dot{\theta}$ at various θ 's. But $\dot{\theta}_0 = 0$ (mass starts from rest), therefore $\dot{\theta} = \sqrt{2\ddot{\theta}\theta}$. Now we make a table for computing the velocities at different positions:

Position (θ)	θ in radians	$\dot{\theta} = \sqrt{2\ddot{\theta}\theta}$	$\vec{v} = R\dot{\theta}\hat{e}_\theta$
0°	0	0 rad/s	$\vec{0}$
30°	$\pi/6$	$\sqrt{10\pi/6} = 2.29 \text{ rad/s}$	$0.57 \text{ m/s } \hat{e}_\theta$
90°	$\pi/2$	$\sqrt{10\pi/2} = 3.96 \text{ rad/s}$	$0.99 \text{ m/s } \hat{e}_\theta$
210°	$7\pi/6$	$\sqrt{70\pi/6} = 2.29 \text{ rad/s}$	$1.51 \text{ m/s } \hat{e}_\theta$

The computed velocities are shown in Fig. 13.13.

2. The acceleration of the mass is given by

$$\begin{aligned} \vec{a} &= \overbrace{a_R \hat{e}_R}^{\text{radial}} + \overbrace{a_\theta \hat{e}_\theta}^{\text{tangential}} \\ &= -R\dot{\theta}^2 \hat{e}_R + R\ddot{\theta} \hat{e}_\theta. \end{aligned}$$

Since $\ddot{\theta}$ is constant, the tangential component of the acceleration is constant at all positions. We have already calculated $\dot{\theta}$ at various positions, so we can easily calculate the radial (also called the normal) component of the acceleration. Thus we can find the acceleration. For example, at $\theta = 30^\circ$,

$$\begin{aligned} \vec{a} &= -R\dot{\theta}^2 \hat{e}_R + R\ddot{\theta} \hat{e}_\theta \\ &= -0.25 \text{ m} \cdot \frac{10\pi}{6} \frac{1}{\text{s}^2} \hat{e}_R + 0.25 \text{ m} \cdot 5 \frac{1}{\text{s}^2} \hat{e}_\theta \\ &= -1.31 \text{ m/s}^2 \hat{e}_R + 1.25 \text{ m/s}^2 \hat{e}_\theta. \end{aligned}$$

Similarly, we find the acceleration of the mass at other positions by substituting the values of R , $\dot{\theta}$ and $\ddot{\theta}$ in the formula and tabulate the results in the table below.

② We use this formula because we need $\dot{\theta}$ at different values of θ . In elementary physics books, the same formula is usually written as

$$\dot{\theta}^2 = \dot{\theta}_0^2 + 2\alpha\theta$$

where α is the constant angular acceleration and $\dot{\theta}(= \dot{\theta})$ is the angular speed.

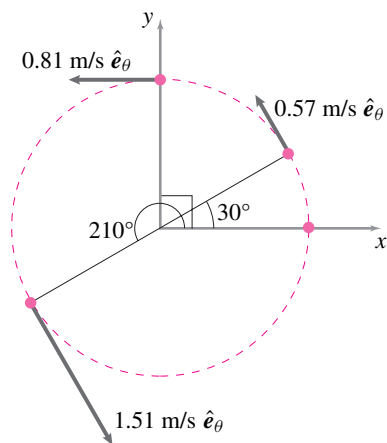

Figure 13.13: Velocity of the mass at $\theta = 0^\circ, 30^\circ, 90^\circ$, and 210° .

Filename: sfig5-1-1a

Position (θ)	$a_r = -R\dot{\theta}^2$	$a_\theta = R\ddot{\theta}$	$\vec{a} = a_r \hat{e}_R + a_\theta \hat{e}_\theta$
0°	0	1.25 m/s^2	$1.25 \text{ m/s}^2 \hat{e}_\theta$
30°	-1.31 m/s^2	1.25 m/s^2	$(-1.31 \hat{e}_R + 1.25 \hat{e}_\theta) \text{ m/s}^2$
90°	-3.93 m/s^2	1.25 m/s^2	$(-3.93 \hat{e}_R + 1.25 \hat{e}_\theta) \text{ m/s}^2$
210°	-9.16 m/s^2	1.25 m/s^2	$(-9.16 \hat{e}_R + 1.25 \hat{e}_\theta) \text{ m/s}^2$

The accelerations computed are shown in Fig. 13.14. The acceleration vector as well as its tangential and radial components are shown in the figure at each position.

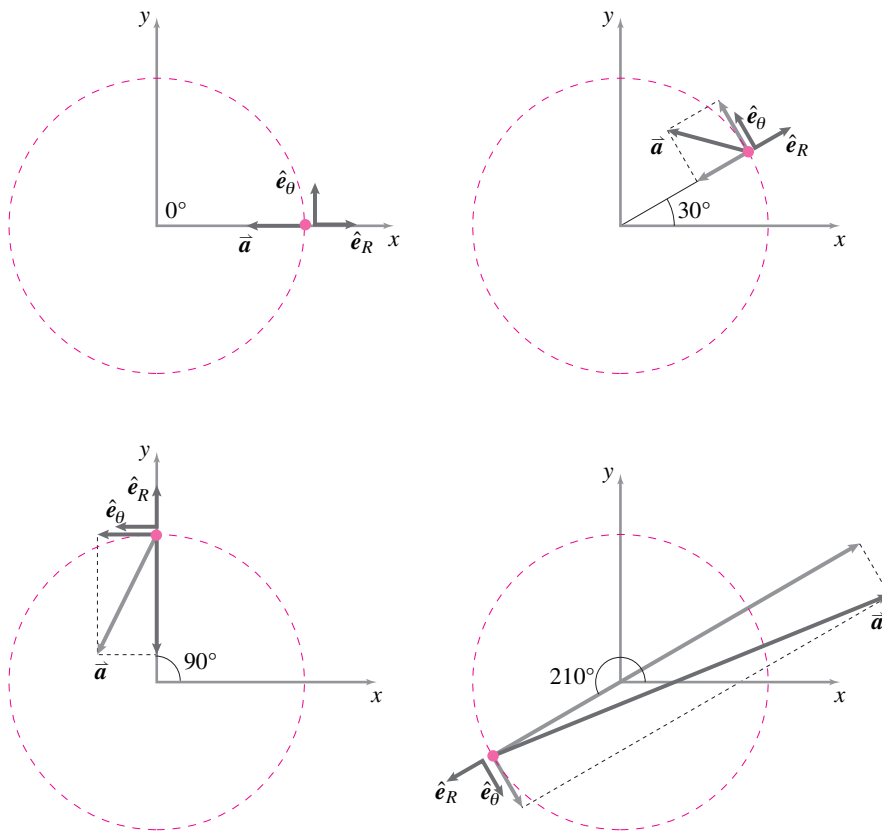

Figure 13.14: Acceleration of the mass at $\theta = 0^\circ$, 30° , 90° , and 210° . The radial and tangential components are shown with grey arrows. As the angular velocity increases, the radial component of the acceleration increases; therefore, the total acceleration vector leans more and more towards the radial direction.

Filename: fig5-1-1b

SAMPLE 13.3 In an experiment, the magnitude of angular deceleration of a rotating ball is found to be proportional to its angular speed $\dot{\theta}$ (i.e., $\ddot{\theta} \propto -\dot{\theta}$). Assume that the proportionality constant is k .

1. Find $\dot{\theta}$ as a function of t , given that $\dot{\theta}(t = 0) = \dot{\theta}_0$.
2. Given that $k = 0.1/\text{s}$, how much time does it take for $\dot{\theta}$ to reduce to half the initial value?

Solution The equation given is:

$$\ddot{\theta} = \frac{d\dot{\theta}}{dt} = -k\dot{\theta}. \quad (13.8)$$

1. We can solve this equation in a couple of ways.

Method-1: Let us guess a solution of the exponential form with arbitrary constants and plug it into eqn. (13.8) to check if our solution works. Let $\dot{\theta}(t) = C_1 e^{C_2 t}$. Substituting in eqn. (13.8), we get

$$\begin{aligned} C_1 C_2 e^{C_2 t} &= -k C_1 e^{C_2 t} \\ \Rightarrow C_2 &= -k, \\ \text{also, } \dot{\theta}(0) &= \dot{\theta}_0 = C_1 e^{C_2 \cdot 0} \\ \Rightarrow C_1 &= \dot{\theta}_0. \end{aligned}$$

Therefore,

$$\dot{\theta}(t) = \dot{\theta}_0 e^{-kt}. \quad (13.9)$$

$$\dot{\theta}(t) = \dot{\theta}_0 e^{-kt}$$

Method-2: Equation (13.8) can also be solved by direct integration as follows.

$$\begin{aligned} \frac{d\dot{\theta}}{\dot{\theta}} &= -k dt \\ \Rightarrow \int_{\dot{\theta}_0}^{\dot{\theta}(t)} \frac{d\dot{\theta}}{\dot{\theta}} &= -\int_0^t k dt \\ \Rightarrow \ln \dot{\theta} \Big|_{\dot{\theta}_0}^{\dot{\theta}(t)} &= -kt \\ \Rightarrow \ln \dot{\theta}(t) - \ln \dot{\theta}_0 &= -kt \\ \Rightarrow \ln \left(\frac{\dot{\theta}(t)}{\dot{\theta}_0} \right) &= -kt \\ \Rightarrow \frac{\dot{\theta}(t)}{\dot{\theta}_0} &= e^{-kt}. \end{aligned}$$

Therefore,

$$\dot{\theta}(t) = \dot{\theta}_0 e^{-kt},$$

which is the same solution as equation (13.9).

2. We need to find t for $\dot{\theta} = \dot{\theta}_0/2$, given that $k = 0.1$. From eqn. (13.9), we get

$$\begin{aligned} \frac{\dot{\theta}}{\dot{\theta}_0} &= e^{-kt} \\ \Rightarrow t &= \frac{1}{-k} \ln \left(\frac{\dot{\theta}}{\dot{\theta}_0} \right) \\ &= \frac{1}{-0.1} \ln \left(\frac{1}{2} \right) = \frac{-0.693}{-0.1/\text{s}} = 6.93 \text{ s}. \end{aligned}$$

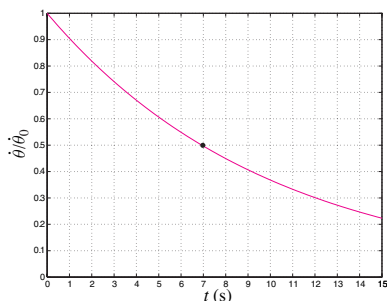

Figure 13.15: Plot of $\dot{\theta}(t)/\dot{\theta}_0 = e^{-kt}$ for $k = -0.1/\text{s}$. The angular speed $\dot{\theta}$ reduces to half of its initial value in 6.93 s. Note that this time is the same for $\dot{\theta}$ to reduce to half its value at any given time t (not just at $t = 0$).

Filename: fig13-1-decaying-omega

$$t = 6.93 \text{ s for } \dot{\theta}(t) = \dot{\theta}_0/2$$

SAMPLE 13.4 Using kinematic formulae: The spinning wheel of a stationary exercise bike is brought to rest from 100 rpm by applying brakes over a period of 5 seconds.

1. Find the average angular deceleration of the wheel.
2. Find the number of revolutions it makes during the braking.

Solution We are given,

$$\dot{\theta}_0 = 100 \text{ rpm}, \quad \dot{\theta}_{\text{final}} = 0, \quad \text{and} \quad t = 5 \text{ s}.$$

1. Let α be the average (constant) deceleration. Then

$$\dot{\theta}_{\text{final}} = \dot{\theta}_0 - \alpha t.$$

Therefore,

$$\begin{aligned} \alpha &= \frac{\dot{\theta}_0 - \dot{\theta}_{\text{final}}}{t} \\ &= \frac{100 \text{ rpm} - 0 \text{ rpm}}{5 \text{ s}} \\ &= \frac{100 \text{ rev}}{60 \text{ s}} \cdot \frac{1}{5 \text{ s}} \\ &= 0.33 \frac{\text{rev}}{\text{s}^2}. \end{aligned}$$

$$\alpha = 0.33 \frac{\text{rev}}{\text{s}^2}$$

2. To find the number of revolutions made during the braking period, we use the formula

$$\theta(t) = \underbrace{\theta_0}_0 + \dot{\theta}_0 t + \frac{1}{2}(-\alpha)t^2 = \dot{\theta}_0 t - \frac{1}{2}\alpha t^2.$$

Substituting the known values, we get

$$\begin{aligned} \theta &= \frac{100 \text{ rev}}{60 \text{ s}} \cdot 5 \text{ s} - \frac{1}{2} \cdot 0.33 \frac{\text{rev}}{\text{s}^2} \cdot 25 \text{ s}^2 \\ &= 8.33 \text{ rev} - 4.12 \text{ rev} \\ &= 4.21 \text{ rev}. \end{aligned}$$

$$\theta = 4.21 \text{ rev}$$

Comments:

- Note the negative sign used in both the formulae above. Since α is deceleration, that is, a negative acceleration, we have used negative sign with α in the formulae.
- Note that it is not always necessary to convert rpm in rad/s. Here we changed rpm to rev/s because time was given in seconds.

SAMPLE 13.5 Non-constant acceleration: A particle of mass 500 grams executes circular motion with radius $R = 100$ cm and angular acceleration $\ddot{\theta}(t) = c \sin \beta t$, where $c = 2 \text{ rad/s}^2$ and $\beta = 2 \text{ rad/s}$.

1. Find the position of the particle after 10 seconds if the particle starts from rest, that is, $\theta(0) = 0$.
2. How much kinetic energy does the particle have at the position found above?

Solution

1. We are given $\ddot{\theta}(t) = c \sin \beta t$, $\dot{\theta}(0) = 0$ and $\theta(0) = 0$. We have to find $\theta(10 \text{ s})$. Basically, we have to solve a second order differential equation with given initial conditions.

$$\begin{aligned}\ddot{\theta} &\equiv \frac{d}{dt}(\dot{\theta}) = c \sin \beta t \\ \Rightarrow \int_{\dot{\theta}_0=0}^{\dot{\theta}(t)} d\dot{\theta} &= \int_0^t c \sin \beta \tau d\tau \\ \dot{\theta}(t) &= -\frac{c}{\beta} \cos \beta \tau \Big|_0^t = \frac{c}{\beta} (1 - \cos \beta t).\end{aligned}$$

Thus, we get the expression for the angular speed $\dot{\theta}(t)$. We can solve for the position $\theta(t)$ by integrating once more:

$$\begin{aligned}\dot{\theta} &\equiv \frac{d}{dt}(\theta) = \frac{c}{\beta} (1 - \cos \beta t) \\ \Rightarrow \int_{\theta_0=0}^{\theta(t)} d\theta &= \int_0^t \frac{c}{\beta} (1 - \cos \beta \tau) d\tau \\ \theta(t) &= \frac{c}{\beta} \left[\tau - \frac{\sin \beta \tau}{\beta} \right]_0^t \\ &= \frac{c}{\beta^2} (\beta t - \sin \beta t).\end{aligned}$$

Now substituting $t = 10 \text{ s}$ in the last expression along with the values of other constants, we get

$$\begin{aligned}\theta(10 \text{ s}) &= \frac{2 \text{ rad/s}^2}{(2 \text{ rad/s})^2} [2 \text{ rad/s} \cdot 10 \text{ s} - \sin(2 \text{ rad/s} \cdot 10 \text{ s})] \\ &= 9.54 \text{ rad}.\end{aligned}$$

$$\theta = 9.54 \text{ rad}$$

2. The kinetic energy of the particle is given by

$$\begin{aligned}E_K &= \frac{1}{2} m v^2 = \frac{1}{2} m (R \dot{\theta})^2 \\ &= \frac{1}{2} m R^2 \underbrace{\left[\frac{c}{\beta} (1 - \cos \beta t) \right]^2}_{\dot{\theta}(t)} \\ &= \frac{1}{2} \cdot 0.5 \text{ kg} \cdot 1 \text{ m}^2 \cdot \left[\frac{2 \text{ rad/s}^2}{2 \text{ rad/s}} \cdot (1 - \cos(20)) \right]^2 \\ &= 0.086 \text{ kg} \cdot \text{m}^2 \cdot \text{s}^{-2} = 0.086 \text{ Joule}.\end{aligned}$$

$$E_K = 0.086 \text{ J}$$

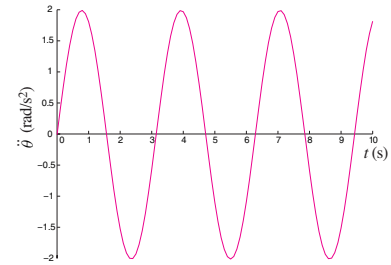

Figure 13.16: Time varying angular acceleration, $\ddot{\theta}(t) = c \sin \beta t$.

Filename:fig13-1-5alpha

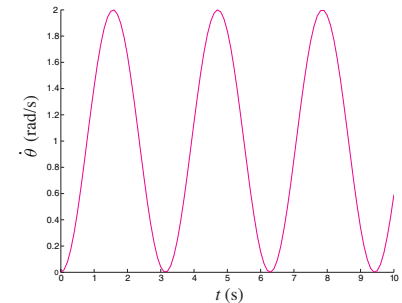

Figure 13.17: Angular speed, $\dot{\theta}(t) = \frac{c}{\beta} (1 - \cos \beta t)$, plotted against time for $c = 2 \text{ rad/s}^2$ and $\beta = 2 \text{ rad/s}$.

Filename:fig13-1-5omega

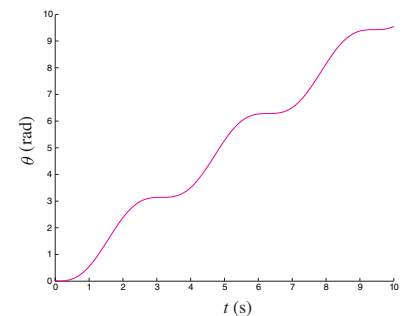

Figure 13.18: Angular position, $\theta(t) = \frac{c}{\beta^2} (\beta t - \sin \beta t)$, plotted against time for $c = 2 \text{ rad/s}^2$ and $\beta = 2 \text{ rad/s}$.

Filename:fig13-1-5theta

13.2 Dynamics of a particle in circular motion

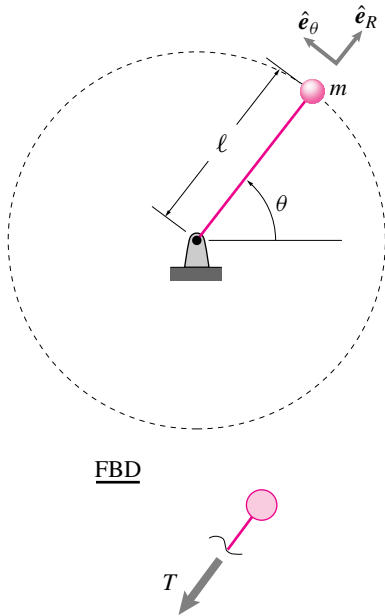

Figure 13.19: Point mass spinning in circles. Sketch of system and a free body diagram.

Filename: figure4-1-rockandstring

The simplest examples of circular motion concern the motion of a particle constrained by a massless connection to be a fixed distance from a support point.

Example: Rock spinning on a string

Neglecting gravity, we can now deal with the familiar problem of a point mass being held in constant circular-rate motion by a massless string or rod. Linear momentum balance for the mass gives:

$$\begin{aligned} \sum \vec{F}_i &= \dot{\vec{L}} \\ \Rightarrow -T \hat{e}_R &= m \vec{a} \\ \{-T \hat{e}_R &= m(-\dot{\theta}^2 \ell \hat{e}_R)\} \\ \{\} \cdot \hat{e}_R &\Rightarrow T = \dot{\theta}^2 \ell m = (v^2/\ell)m \end{aligned}$$

The force required to keep a mass in constant rate circular motion is mv^2/ℓ (sometimes remembered as mv^2/R).

The simplest example of ‘celestial mechanics’ is also circular motion.

Example: Geosynchronous orbit

Assuming a spherical earth, the centrally acting force of earth’s gravity on a satellite is mg at the earth’s surface and decays with radius squared so is

$$F = mg \frac{R_e^2}{r^2}$$

where R_e is the radius of the earth and r is the distance of the satellite from the center of the earth. Linear momentum balance for the mass gives:

$$\begin{aligned} \sum \vec{F}_i &= \dot{\vec{L}} \\ \Rightarrow -mg \frac{R_e^2}{r^2} \hat{e}_R &= m \vec{a} \\ \left\{ -mg \frac{R_e^2}{r^2} \hat{e}_R &= m(-\dot{\theta}^2 r \hat{e}_R) \right\} \\ \{\} \cdot \hat{e}_R &\Rightarrow r = \left(\frac{g R_e^2}{\dot{\theta}^2} \right)^{1/3}. \end{aligned}$$

Communication satellites in ‘geosynchronous’ orbits go around once a day (staying in the sites of millions of satellite dishes). So, using $g \approx 10 \text{ m/s}^2$, $R_e \approx 6400 \text{ km}$ and $\dot{\theta} \approx 1 \text{ rev/day}$, we get $r = 42600 \text{ km}$.

There are various errors in the calculation above, of course. The earth doesn’t rotate once per day, but a little more because it goes around once per day relative to a line connecting the earth and sun. And the force of gravity on a near-earth mass is a big more than mg because ‘ g ’ actually measures the force it takes to hold up a mass on the earth’s surface, which is the gravity force less the acceleration from going in circles on the surface of the earth. And the earth isn’t exactly spherical, and so on. The actual geosynchronous radius is more like 42164 km.

The same calculation can be used to calculate the motion of low altitude satellites, the motion of the moon around the earth and the motion of the earth around the sun.

More complex cases of circular motion are when the motion is not at constant rate.

Because the centrally directed part of a particle's acceleration is sometimes called the 'centripetal' acceleration, the centrally directed force needed to keep a particle in circular motion is sometimes called the 'centripetal' force. Thus, in the first example above the tension in the string is a centripetal force, and in the satellite problem the gravity force is a centripetal force. On the other hand, the 'centrifugal' force is a

The simple pendulum

Perhaps the most famous example of circular motion of a particle is the motion of a simple pendulum. As a child's swing, the inside of a grandfather clock, a hypnotist's device, or a gallows, the motion of a simple pendulum is a clear image to all of us. Galileo studied the simple pendulum before Newton created Newton's laws, and the pendulum is a core topic in high-school and freshman physics.

For starters, we consider a 2-D pendulum of fixed length with no forcing other than gravity. All mass is concentrated at a point. Of primary interest is the motion of the pendulum. First we find governing differential equations.

First, the tension in the pendulum rod (or string) acts along the length because the rod is a massless two-force body. At least that is the idealization. For any real pendulum, where the rod is not precisely massless and where the mass is not precisely concentrated at a point, there is a small force transmitted that is not along the rod. We neglect this 'shear' force in this treatment of the ideal pendulum. One way to get the equation of motion is to use linear momentum balance in polar coordinates, *eqn.* (13.10), and dot both sides with \hat{e}_θ to get

$$\begin{aligned} -T \underbrace{\hat{e}_R \cdot \hat{e}_\theta}_0 + mg \underbrace{\hat{i} \cdot \hat{e}_\theta}_{-\sin \theta} &= m \ell \ddot{\theta} \underbrace{\hat{e}_\theta \cdot \hat{e}_\theta}_1 - \ell \dot{\theta}^2 \underbrace{\hat{e}_R \cdot \hat{e}_\theta}_0 \\ \Rightarrow -mg \sin \theta &= m \ell \ddot{\theta} \\ \text{so } \ddot{\theta} &= -\frac{g}{\ell} \sin \theta. \end{aligned}$$

Small angle approximation (linearization)

For small angles, $\sin \theta \approx \theta$, so we have

$$\ddot{\theta} = -\frac{g}{\ell} \theta$$

for small oscillations. This equation describes a harmonic oscillator with $\frac{g}{\ell}$ replacing the $\sqrt{\frac{k}{m}}$ coefficient in a spring-mass system. Thus the general solution is

$$\theta = A \cos \sqrt{g/\ell} t + B \sin \sqrt{g/\ell} t \quad (13.15)$$

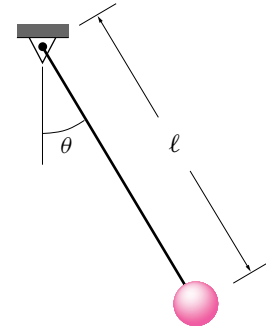

Figure 13.20: The ideal simple pendulum.

Filename:figure5-spend

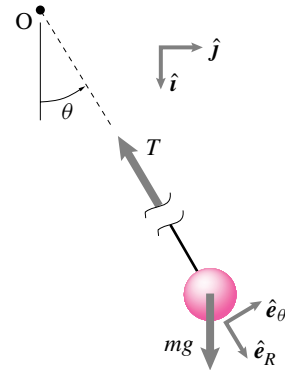

Figure 13.21: Free body diagram of the mass in a simple pendulum.

Filename:figure5-spend-fbd

where $A = \theta_0$ and $B\sqrt{g/l} = \dot{\theta}_0$. This solution has the famous property, Galileo loved this, that the frequency is the same for big as for

13.2 THEORY

Other derivations of the pendulum equation

The simplest derivation of the pendulum differential equation is to use linear momentum balance in polar coordinates. Here are two other derivations.

Method one: linear momentum balance in cartesian coordinates

The equation of linear momentum balance is

$$\sum \vec{F} = \overbrace{m\vec{a}}^{\dot{\vec{L}}}$$

Evaluating the left side (using the free body diagram) and right side (using the kinematics of circular motion), we get

$$-T\hat{e}_R + mg\hat{i} = m[\ell\ddot{\theta}\hat{e}_\theta - \ell\dot{\theta}^2\hat{e}_R] \quad (13.10)$$

From the picture (or recalling) we see that $\hat{e}_R = \cos\theta\hat{i} + \sin\theta\hat{j}$ and $\hat{e}_\theta = \cos\theta\hat{j} - \sin\theta\hat{i}$. So, upon substitution into the equation above, we get

$$-T(\cos\theta\hat{i} + \sin\theta\hat{j}) + mg\hat{i} = m[\ell\ddot{\theta}(\cos\theta\hat{j} - \sin\theta\hat{i}) - \ell\dot{\theta}^2(\cos\theta\hat{i} + \sin\theta\hat{j})]$$

Breaking this equation into its x and y components (by dotting both sides with \hat{i} and \hat{j} , respectively) gives

$$\begin{aligned} -T\cos\theta + mg &= -m\ell(\ddot{\theta}\sin\theta + \dot{\theta}^2\cos\theta) \quad (13.11) \\ -T\sin\theta &= m\ell(\ddot{\theta}\cos\theta - \dot{\theta}^2\sin\theta). \quad (13.12) \end{aligned}$$

Note, when deriving equations of motion, we think of both positions and the rates and velocities as knowns. For example, we take θ and $\dot{\theta}$ as known. But how do we know them? We don't. But think of them as known helps us write a set of differential equations from which we can eventually find them. Thus the equations above are two simultaneous equations that we can solve for the two unknowns T and $\ddot{\theta}$ to get

$$\ddot{\theta} = -\frac{g}{\ell}\sin\theta \quad (13.13)$$

$$T = m[\ell\dot{\theta}^2 + g\cos\theta]. \quad (13.14)$$

The first equation is the familiar pendulum differential equation, the second allows us to find the tension in the pendulum string.

Method two: angular momentum balance

Using angular momentum balance, we can 'kill' (eliminate) the tension term at the start. Taking angular momentum balance about the point O , we get

$$\begin{aligned} \sum \vec{M}_O &= \dot{\vec{H}}_O \\ -mgl\sin\theta\hat{k} &= \vec{r}_{/O} \times \vec{a}m \\ \ell\hat{e}_R & \quad \quad \quad \ell\ddot{\theta}\hat{e}_\theta - \ell\dot{\theta}^2\hat{e}_R \\ -mgl\sin\theta\hat{k} &= m\ell^2\ddot{\theta}\hat{k} \\ \Rightarrow \ddot{\theta} &= -\frac{g}{\ell}\sin\theta \end{aligned}$$

since $\hat{e}_R \times \hat{e}_R = 0$ and $\hat{e}_R \times \hat{e}_\theta = \hat{k}$. So, the governing equation for a simple pendulum is

$$\ddot{\theta} = -\frac{g}{\ell}\sin\theta$$

Method three: Conservation of energy

The string tension is always orthogonal to the velocity so does no work. The gravity force is conservative. So energy is conserved.

$$\begin{aligned} \text{constant} &= E_T \\ \Rightarrow \text{constant} &= E_K + E_P \\ \Rightarrow 0 &= \dot{E}_K + \dot{E}_P \\ \Rightarrow 0 &= \frac{d}{dt}\left(\frac{1}{2}mv^2\right) + \frac{d}{dt}(mgh) \\ \Rightarrow 0 &= \frac{d}{dt}\left(\frac{1}{2}m(\ell\dot{\theta})^2\right) + \frac{d}{dt}(-mgl\cos\theta) \\ \Rightarrow 0 &= m\ell^2\ddot{\theta}\dot{\theta} + mg\ell(\sin\theta)\dot{\theta} \end{aligned}$$

Now m cancels from both sides and we can divide through by ℓ^2 . We can also divide through by $\dot{\theta}$, but for exceptional instants in time when $\dot{\theta} = 0$. Thus

$$\ddot{\theta} + \frac{g}{\ell}\sin\theta = 0$$

which is the familiar differential equation for a pendulum. This method lacks some rigor in that the cancelation of $\dot{\theta}$ is not valid at exactly every instant in time. However, it is valid for all but those instants, and happens to give the right answer at the exceptional instants as well.

small oscillations. Thus, a pendulum of a given length that swings back and forth 1 degree makes about the same number of swings per minute as one that swings with an amplitude of 10 degrees. How big is the error in this constant frequency result? Well, something less than the error in the approximation that $\sin \theta = \theta$.

$$\%error = 100 \cdot \frac{\theta - \sin \theta}{\sin \theta} \approx 100 \cdot \frac{\theta^3/3}{\theta} \approx \frac{\theta^2}{3} \approx 1\%$$

for $\theta = 10^\circ \approx 1/6$ rad. The actual error in the period is less than this, as you can find by numerically solving the non-linear pendulum equation.

The inverted pendulum

A pendulum with the mass-end up is called an inverted pendulum. By methods just like we used for the regular pendulum, we find the equation of motion to be

$$\ddot{\theta} = \frac{g}{\ell} \sin \theta$$

which, for small θ , is well approximated by

$$\ddot{\theta} = \frac{g}{\ell} \theta.$$

As opposed to the simple pendulum, which has oscillatory solutions, this differential equation has exponential solutions ($\theta = C_1 e^{gt/\ell} + C_2 e^{-gt/\ell}$), one term of which has exponential growth, indicating the inherent *instability* of the inverted pendulum. That is it has tendency to fall over when slightly disturbed from the vertical position^①.

13.3 More about pendula

Now a days the pendulum is popular as an example of “chaos”; if you push a pendulum periodically its motions can be wild. Pendula are useful as models of many phenomena from the swing of leg joints in walking to the tipping of a chimney in an earthquake. Pendula also serve as a simple example for many concepts in mechanics.

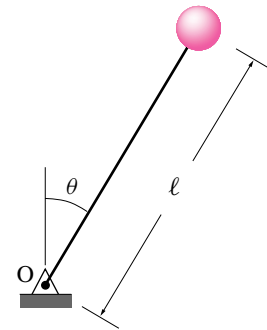

Figure 13.22: The inverted pendulum

Filename:figure5-spend-inv

① After the pendulum falls a ways, say past 30 degrees from vertical, the exponential solution is not an accurate description, but the actual motion (as viewed by an experiment, a computer simulation, or the exact elliptic integral solution of the equations) shows that the pendulum keeps falling.

SAMPLE 13.6 A uniform bar AB of length $\ell = 50$ cm rotates counterclockwise about point A with constant angular speed ω . At the instant shown in *Fig. 13.23* the linear speed v_C of the center-of-mass C is 7.5 cm/s.

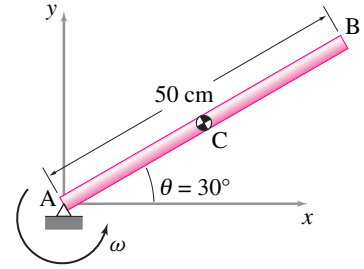

Figure 13.23:

Filename:fig4-4-1

1. What is the angular speed of the bar?
2. What is the angular velocity of the bar?
3. What is the linear velocity of end B?
4. By what angles do the angular positions of points C and B change in 2 seconds?

Solution Let the angular velocity of the bar be $\vec{\omega} = \dot{\theta}\hat{k}$ where $\dot{\theta}$ is the angular speed. We first need to find $\dot{\theta}$.

1. The linear speed of point C is given, $v_C = 7.5$ cm/s. Now,

$$\begin{aligned} v_C &= \dot{\theta} r_C \\ \Rightarrow \dot{\theta} &= \frac{v_C}{r_C} = \frac{7.5 \text{ cm/s}}{25 \text{ cm}} = 0.3 \text{ rad/s.} \end{aligned}$$

$$\dot{\theta} = 0.3 \text{ rad/s}$$

2. The angular velocity of the bar is $\vec{\omega} = \dot{\theta}\hat{k} = 0.3 \text{ rad/s}\hat{k}$.

$$\vec{\omega} = 0.3 \text{ rad/s}\hat{k}$$

3. Point B is at distance ℓ from the pivot point A. Thus it goes around a circle of radius ℓ (see *Fig. 13.25*). Therefore,

$$\begin{aligned} \vec{v}_B &= \vec{\omega} \times \vec{r}_B = \dot{\theta}\hat{k} \times \ell(\cos\theta\hat{i} + \sin\theta\hat{j}) \\ &= \dot{\theta}\ell(\cos\theta\hat{j} - \sin\theta\hat{i}) \\ &= 0.3 \text{ rad/s} \cdot 50 \text{ cm} \left(\frac{\sqrt{3}}{2}\hat{j} - \frac{1}{2}\hat{i} \right) \\ &= 15 \text{ cm/s} \left(\frac{\sqrt{3}}{2}\hat{j} - \frac{1}{2}\hat{i} \right). \end{aligned}$$

$$\vec{v}_B = 15 \text{ cm/s} \left(\frac{\sqrt{3}}{2}\hat{j} - \frac{1}{2}\hat{i} \right)$$

We can also write $\vec{v}_B = 15 \text{ cm/s} \cdot \hat{e}_\theta$ where $\hat{e}_\theta = \frac{\sqrt{3}}{2}\hat{j} - \frac{1}{2}\hat{i}$.

4. Let θ_1 be the position of point C at some time t_1 and θ_2 be the position at time t_2 . We want to find $\Delta\theta = \theta_2 - \theta_1$ for $t_2 - t_1 = 2$ s.

$$\begin{aligned} \frac{d\theta}{dt} &= \dot{\theta} = \text{constant} = 0.3 \text{ rad/s.} \\ \Rightarrow d\theta &= (0.3 \text{ rad/s})dt. \\ \Rightarrow \int_{\theta_1}^{\theta_2} d\theta &= \int_{t_1}^{t_2} (0.3 \text{ rad/s})dt. \\ \Rightarrow \theta_2 - \theta_1 &= 0.3 \text{ rad/s}(t_2 - t_1) \\ \text{or } \Delta\theta &= 0.3 \frac{\text{rad}}{\text{s}} \cdot 2\text{s} = 0.6 \text{ rad.} \end{aligned}$$

The change in angular position of point B is the same as that of point C. In fact, all points on AB undergo the same change in angular position because AB is a rigid body.

$$\Delta\theta_C = \Delta\theta_B = 0.6 \text{ rad}$$

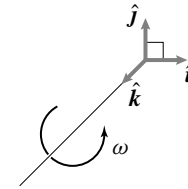

Figure 13.24:

Filename:fig4-4-1a

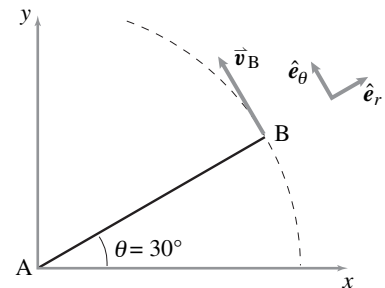

Figure 13.25: From the given geometry, $\hat{e}_r = \cos\theta\hat{i} + \sin\theta\hat{j}$, $\hat{e}_\theta = -\sin\theta\hat{i} + \cos\theta\hat{j}$, and $\vec{v}_B = |\vec{v}_B|\hat{e}_\theta$.

Filename:fig4-4-1b

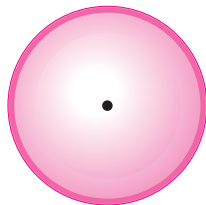

Figure 13.26:
Filename:fig13-3-wheel

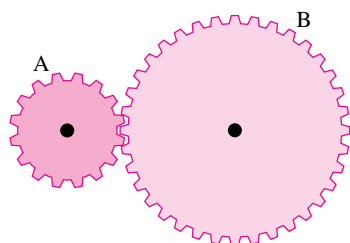

Figure 13.27:
Filename:fig4-4-3

SAMPLE 13.7 A flywheel of diameter 2 ft is made of cast iron. To avoid extremely high stresses and cracks it is recommended that the peripheral speed not exceed 6000 to 7000 ft/min. What is the corresponding rpm rating for the wheel?

Solution

$$\begin{aligned}\text{Diameter of the wheel} &= 2 \text{ ft.} \\ \Rightarrow \text{radius of wheel} &= 1 \text{ ft.}\end{aligned}$$

Now,

$$\begin{aligned}v &= \omega r \\ \Rightarrow \omega &= \frac{v}{r} = \frac{6000 \text{ ft/min}}{1 \text{ ft}} \\ &= 6000 \frac{\text{rad}}{\text{min}} \cdot \frac{1 \text{ rev}}{2\pi \text{ rad}} \\ &= 955 \text{ rpm.}\end{aligned}$$

Similarly, corresponding to $v = 7000 \text{ ft/min}$

$$\begin{aligned}\omega &= \frac{7000 \text{ ft/min}}{1 \text{ ft}} \\ &= 7000 \frac{\text{rad}}{\text{min}} \cdot \frac{1 \text{ rev}}{2\pi \text{ rad}} \\ &= 1114 \text{ rpm.}\end{aligned}$$

Thus the rpm rating of the wheel should read 955 – 1114 rpm.

$$\omega = 955 \text{ to } 1114 \text{ rpm.}$$

SAMPLE 13.8 Two gears A and B have the diameter ratio of 1:2. Gear A drives gear B. If the output at gear B is required to be 150 rpm, what should be the angular speed of the driving gear? Assume no slip at the contact point.

Solution Let C and C' be the points of contact on gear A and B respectively at some instant t . Since there is no relative slip between C and C', both points must have the same linear velocity at instant t . If the velocities are the same, then the linear speeds must also be the same. Thus

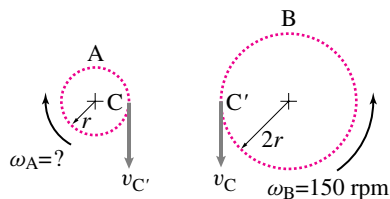

Figure 13.28:
Filename:fig4-4-3a

$$\begin{aligned}v_C &= v_{C'} \\ \Rightarrow \omega_A r_A &= \omega_B r_B \\ \Rightarrow \omega_A &= \omega_B \frac{r_B}{r_A} \\ &= \omega_B \cdot \frac{2r}{r} = 2\omega_B \\ &= (2) \cdot (150 \text{ rpm}) \\ &= 300 \text{ rpm.}\end{aligned}$$

$$\omega_A = 300 \text{ rpm}$$

SAMPLE 13.9 A uniform rigid rod AB of length $\ell = 0.6$ m is connected to two rigid links OA and OB. The assembly rotates at a constant rate about point O in the xy plane. At the instant shown, when rod AB is vertical, the velocities of points A and B are $\vec{v}_A = -4.64 \text{ m/s} \hat{j} - 1.87 \text{ m/s} \hat{i}$, and $\vec{v}_B = 1.87 \text{ m/s} \hat{i} - 4.64 \text{ m/s} \hat{j}$. Find the angular velocity of bar AB. What is the length R of the links?

Solution Let the angular velocity of the rod AB be $\vec{\omega} = \omega \hat{k}$. ① Since we are given the velocities of two points on the rod we can use the relative velocity formula to find $\vec{\omega}$:

$$\begin{aligned} \vec{v}_{B/A} &= \vec{\omega} \times \vec{r}_{B/A} = \vec{v}_B - \vec{v}_A \\ \text{or } \underbrace{\omega \hat{k}}_{\vec{\omega}} \times \underbrace{\ell \hat{j}}_{\vec{r}_{B/A}} &= (1.87\hat{i} - 4.64\hat{j}) \text{ m/s} - (-4.64\hat{j} - 1.87\hat{i}) \text{ m/s} \\ \text{or } \omega \ell (-\hat{i}) &= (1.87\hat{i} + 1.87\hat{i}) \text{ m/s} - (4.64\hat{j} - 4.64\hat{j}) \text{ m/s} \\ &= 3.74\hat{i} \text{ m/s} \\ \Rightarrow \omega &= -\frac{3.74 \text{ m/s}}{\ell} \\ &= -\frac{3.74}{0.6} \text{ rad/s} \\ &= -6.233 \text{ rad/s} \end{aligned} \quad (13.16)$$

Thus,

$$\vec{\omega} = -6.233 \text{ rad/s} \hat{k}. \quad (13.17)$$

$$\vec{\omega} = -6.23 \text{ rad/s} \hat{k}$$

Let θ be the angle between link OA and the horizontal axis. Now,

$$\vec{v}_A = \vec{\omega} \times \vec{r}_A = \omega \hat{k} \times \underbrace{R(\cos \theta \hat{i} - \sin \theta \hat{j})}_{\vec{r}_A}$$

$$\text{or } (-4.64\hat{j} - 1.87\hat{i}) \text{ m/s} = \omega R(\cos \theta \hat{j} + \sin \theta \hat{i})$$

Dotting both sides of the equation with \hat{i} and \hat{j} we get

$$-1.87 \text{ m/s} = \omega R \sin \theta \quad (13.18)$$

$$-4.64 \text{ m/s} = \omega R \cos \theta \quad (13.19)$$

Squaring and adding Eqns (13.18) and (13.19) together we get

$$\begin{aligned} \omega^2 R^2 &= (-4.64 \text{ m/s})^2 + (-1.87 \text{ m/s})^2 \\ &= 25.026 \text{ m}^2/\text{s}^2 \\ \Rightarrow R^2 &= \frac{25.026 \text{ m}^2/\text{s}^2}{(-6.23 \text{ rad/s})^2} \\ &= 0.645 \text{ m}^2 \\ \Rightarrow R &= 0.8 \text{ m} \end{aligned}$$

$$R = 0.8 \text{ m}$$

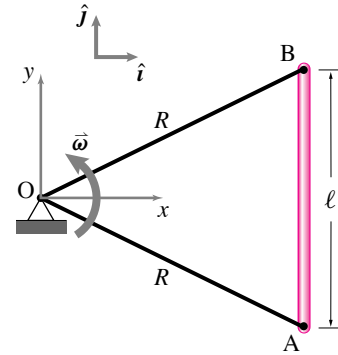

Figure 13.29:

Filename:fig4-4-4

① We know that the rod rotates about the z -axis but we do not know the sense of the rotation *i.e.*, $+\hat{k}$ or $-\hat{k}$. Here we have assumed that $\vec{\omega}$ is in the positive \hat{k} direction, although just by sketching \vec{v}_A we can easily see that $\vec{\omega}$ must be in the $-\hat{k}$ direction.

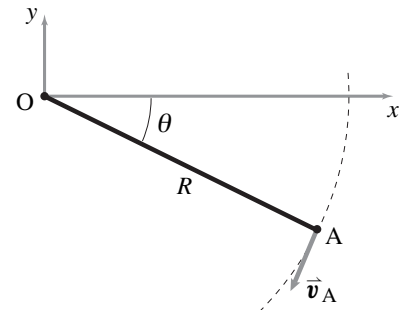

Figure 13.30: The given velocity vector \vec{v}_A . Since $\vec{v}_A = \vec{\omega} \times \vec{r}_A$ where $\vec{r}_A = R \cos \theta \hat{i} + R \sin \theta \hat{j}$, we can find R from the given \vec{v}_A .

Filename:fig4-4-4a

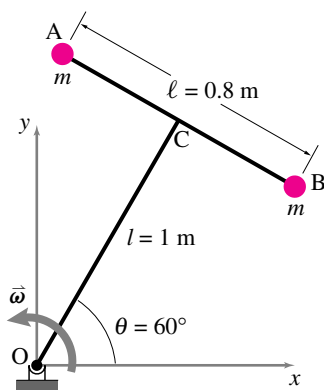

Figure 13.31:

Filename:fig4-3-1

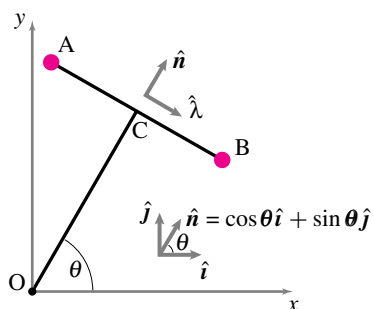

Figure 13.32:

Filename:fig4-3-1a

② The vector $\vec{r}_{B/A}$ may also be expressed directly in terms of unit vectors \hat{i} and \hat{j} , but it involves a little bit more geometry. Note how assuming $\hat{\lambda}$ and \hat{n} in the directions shown makes calculations easier and cleaner.

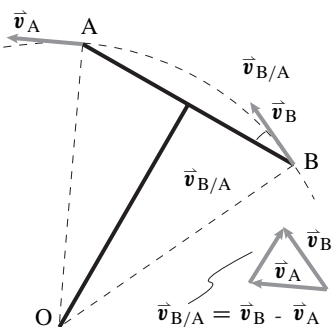

Figure 13.33:

Filename:fig4-3-1b

SAMPLE 13.10 A dumbbell AB, made of two equal masses and a rigid rod AB of negligible mass, is welded to a rigid arm OC, also of negligible mass, such that OC is perpendicular to AB. Arm OC rotates about O at a constant angular velocity $\vec{\omega} = 10 \text{ rad/s} \hat{k}$. At the instant when $\theta = 60^\circ$, find the relative velocity of B with respect to A.

Solution Since A and B are two points on the same rigid body (AB) and the body is spinning about point O at a constant rate, we may use the relative velocity formula

$$\vec{v}_{B/A} \equiv \vec{v}_B - \vec{v}_A = \vec{\omega} \times \vec{r}_{B/A} \quad (13.20)$$

to find the relative velocity of B with respect to A. We are given $\vec{\omega} = \omega \hat{k} = 10 \text{ rad/s} \hat{k}$. Let $\hat{\lambda}$ and \hat{n} be unit vectors parallel to AB and OC respectively. Since $OC \perp AB$, we have $\hat{n} \perp \hat{\lambda}$. Now we may write vector $\vec{r}_{B/A}$ as ②

$$\vec{r}_{B/A} = \ell \hat{\lambda}.$$

Substituting $\vec{\omega}$ and $\vec{r}_{B/A}$ in Eqn (13.20) we get

$$\begin{aligned} \vec{v}_{B/A} &= \omega \hat{k} \times \ell \hat{\lambda} \\ &= \omega \ell (\hat{k} \times \hat{\lambda}) \\ &= \omega \ell \hat{n} \\ &= \omega \ell (\cos \theta \hat{i} + \sin \theta \hat{j}) \\ &= 10 \text{ rad/s} (0.8 \text{ m}) \cdot \left(\frac{1}{2} \hat{i} + \frac{\sqrt{3}}{2} \hat{j} \right) \\ &= 4 \text{ m/s} (\hat{i} + \sqrt{3} \hat{j}). \end{aligned}$$

$$\vec{v}_{B/A} = 4 \text{ m/s} (\hat{i} + \sqrt{3} \hat{j})$$

Comments: $\vec{v}_{B/A}$ can also be obtained by adding vectors \vec{v}_B and $-\vec{v}_A$ geometrically. Since A and B execute circular motion with the same radius $R = OA = OB$, the magnitudes of \vec{v}_B and \vec{v}_A are the same ($= \omega R$) and since the velocity in circular motion is tangential to the circular path, $\vec{v}_A \perp OA$ and $\vec{v}_B \perp OB$. Then moving \vec{v}_A to point B, we can easily find $\vec{v}_B - \vec{v}_A = \vec{v}_{B/A}$. Its direction is found to be perpendicular to AB, *i.e.*, along OC. Thus, the velocity of B with respect to A is that of circular motion of point B about point A. That is, if you sit at A, you will see B going around you in circles of radius ℓ and at angular rate ω .

SAMPLE 13.11 For the same problem and geometry as in Sample 13.10, find the acceleration of point B relative to point A.

Solution Since points A and B are on the same rigid body AB which is rotating at a constant rate $\omega = 10 \text{ rad/s}$, the relative acceleration of B is:

$$\begin{aligned}\vec{a}_{B/A} &= \vec{a}_B - \vec{a}_A = \vec{\omega} \times (\vec{\omega} \times \vec{r}_{B/A}) \\ &= \omega \hat{k} \times (\omega \hat{k} \times \ell \hat{\lambda}) \\ &= \omega \hat{k} \times \omega \ell \hat{n} \quad (\text{since } \hat{k} \times \hat{\lambda} = \hat{n}) \\ &= \omega^2 \ell (\hat{k} \times \hat{n}) \\ &= \omega^2 \ell (-\hat{\lambda}).\end{aligned}$$

③ Now we need to express $\hat{\lambda}$ in terms of known basis vectors \hat{i} and \hat{j} . If you are good with geometry, then by knowing that $\hat{\lambda} \perp \hat{n}$ and $\hat{n} = \cos \theta \hat{i} + \sin \theta \hat{j}$ you can immediately write

$$\hat{\lambda} = \sin \theta \hat{i} - \cos \theta \hat{j} \quad (\text{so that } \hat{\lambda} \cdot \hat{n} = 0).$$

Or you may draw a big and clear picture of $\hat{\lambda}$, \hat{n} , \hat{i} and \hat{j} and label the angles as shown in Fig 13.34. Then, it is easy to see that

$$\hat{\lambda} = \sin \theta \hat{i} - \cos \theta \hat{j}.$$

Substituting for $\hat{\lambda}$ in the expression for $\vec{a}_{B/A}$, we get

$$\begin{aligned}\vec{a}_{B/A} &= -\omega^2 \ell (\sin \theta \hat{i} - \cos \theta \hat{j}) \\ &= -100 \frac{\text{rad}^2}{\text{s}^2} \cdot \left[0.8 \text{ m} \left(\frac{\sqrt{3}}{2} \hat{i} - \frac{1}{2} \hat{j} \right) \right] \\ &= -40 \text{ m/s}^2 (\sqrt{3} \hat{i} - \hat{j}).\end{aligned}$$

$$\vec{a}_{B/A} = -40 \text{ m/s}^2 (\sqrt{3} \hat{i} - \hat{j})$$

Comments: We could also find $\vec{a}_{B/A}$ using geometry and geometric addition of vectors. Since A and B are going in circles about O at constant speed, their accelerations are centripetal accelerations. Thus, \vec{a}_A points along AO and \vec{a}_B points along BO. Also $|\vec{a}_A| = |\vec{a}_B| = \omega^2(OA)$. Now adding $-\vec{a}_A$ to \vec{a}_B we get $\vec{a}_{B/A}$ which is seen to be along BA.

③ If a body rotates in a plane, i.e., $\vec{\omega} = \omega \hat{k}$, then $\vec{\omega} \times (\vec{\omega} \times \vec{r}) = -\omega^2 \vec{r}$. Using this fact we can immediately write $\vec{a}_{B/A} = -\omega^2 \vec{r}_{B/A} = -\omega^2 \ell \hat{\lambda}$.

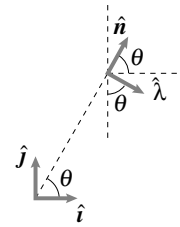

Figure 13.34: The geometry of vectors \hat{i} and \hat{n} . From the figure, $\hat{\lambda} = -\cos \theta \hat{j} + \sin \theta \hat{i}$.

Filename:fig4-3-2

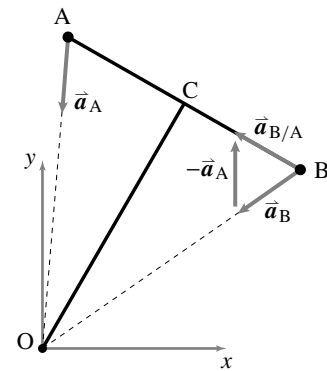

Figure 13.35:

Filename:fig4-3-2a

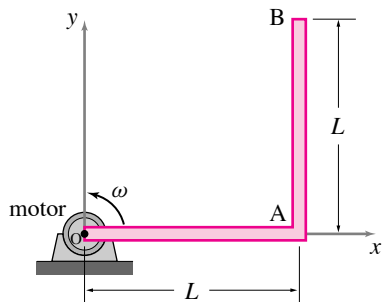

Figure 13.36: An 'L' shaped bar rotates at speed ω about point O.

Filename:fig5-3-1a

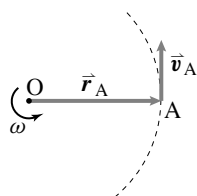

Figure 13.37: $\vec{v}_A = \vec{\omega} \times \vec{r}_A$ is tangential to the circular path of point A.

Filename:fig5-3-1b

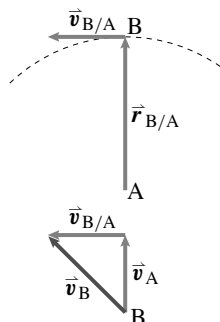

Figure 13.38: $\vec{v}_{B/A} = \vec{\omega} \times \vec{r}_{B/A}$ and $\vec{v}_B = \vec{v}_A + \vec{v}_{B/A}$.

Filename:fig5-3-1c

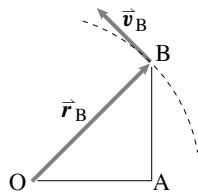

Figure 13.39: $\vec{v}_B = \vec{\omega} \times \vec{r}_B$.

Filename:fig5-3-1d

SAMPLE 13.12 Test the velocity formula on something you know. The motor at O in Fig. 13.36 rotates the 'L' shaped bar OAB in counterclockwise direction at an angular speed which increases at $\dot{\omega} = 2.5 \text{ rad/s}^2$. At the instant shown, the angular speed $\omega = 4.5 \text{ rad/s}$. Each arm of the bar is of length $L = 2 \text{ ft}$.

1. Find the velocity of point A.
2. Find the relative velocity $\vec{v}_{B/A}$ ($= \vec{\omega} \times \vec{r}_{B/A}$) and use the result to find the absolute velocity of point B ($\vec{v}_B = \vec{v}_A + \vec{v}_{B/A}$).
3. Find the velocity of point B directly. Check the answer obtained in part (b) against the new answer.

Solution

1. As the bar rotates, every point on the bar goes in circles centered at point O. Therefore, we can easily find the velocity of any point on the bar using circular motion formula $\vec{v} = \vec{\omega} \times \vec{r}$. Thus,

$$\begin{aligned}\vec{v}_A &= \vec{\omega} \times \vec{r}_A = \omega \hat{k} \times L \hat{i} = \omega L \hat{j} \\ &= 4.5 \text{ rad/s} \cdot 2 \text{ ft} \hat{j} = 9 \text{ ft/s} \hat{j}.\end{aligned}$$

The velocity vector \vec{v}_A is shown in Fig. 13.37.

$$\vec{v}_A = 9 \text{ ft/s} \hat{j}$$

2. Point B and A are on the same rigid body. Therefore, with respect to point A, point B goes in circles about A. Hence the relative velocity of B with respect to A is

$$\begin{aligned}\vec{v}_{B/A} &= \vec{\omega} \times \vec{r}_{B/A} \\ &= \omega \hat{k} \times L \hat{j} = -\omega L \hat{i} \\ &= -4.5 \text{ rad/s} \cdot 2 \text{ ft} \hat{i} = -9 \text{ ft/s} \hat{i}.\end{aligned}$$

and

$$\begin{aligned}\vec{v}_B &= \vec{v}_A + \vec{v}_{B/A} \\ &= 9 \text{ ft/s}(-\hat{i} + \hat{j}).\end{aligned}$$

These velocities are shown in Fig. 13.38.

$$\vec{v}_{B/A} = -9 \text{ ft/s} \hat{i}, \quad \vec{v}_B = 9 \text{ ft/s}(-\hat{i} + \hat{j})$$

3. Since point B goes in circles of radius OB about point O, we can find its velocity directly using circular motion formula:

$$\begin{aligned}\vec{v}_B &= \vec{\omega} \times \vec{r}_B \\ &= \omega \hat{k} \times (L \hat{i} + L \hat{j}) = \omega L (\hat{j} - \hat{i}) \\ &= 9 \text{ ft/s}(-\hat{i} + \hat{j}).\end{aligned}$$

The velocity vector is shown in Fig. 13.39. Of course this velocity is the same velocity as obtained in part (b) above.

$$\vec{v}_B = 9 \text{ ft/s}(-\hat{i} + \hat{j})$$

Note: Nothing in this sample uses $\dot{\omega}$!

SAMPLE 13.13 Test the acceleration formula on something you know. Consider the ‘L’ shaped bar of Sample 13.12 again. At the instant shown, the bar is rotating at 4 rad/s and is slowing down at the rate of 2 rad/s².

- (i) Find the acceleration of point A.
- (ii) Find the relative acceleration $\vec{a}_{B/A}$ of point B with respect to point A and use the result to find the absolute acceleration of point B ($\vec{a}_B = \vec{a}_A + \vec{a}_{B/A}$).
- (iii) Find the acceleration of point B directly and verify the result obtained in (ii).

Solution We are given:

$$\vec{\omega} = \omega \hat{k} = 4 \text{ rad/s} \hat{k}, \quad \text{and} \quad \dot{\vec{\omega}} = -\dot{\omega} \hat{k} = -2 \text{ rad/s}^2 \hat{k}.$$

- (i) Point A is going in circles of radius L. Hence,

$$\begin{aligned} \vec{a}_A &= \dot{\vec{\omega}} \times \vec{r}_A + \vec{\omega} \times (\vec{\omega} \times \vec{r}_A) = \dot{\vec{\omega}} \times \vec{r}_A - \omega^2 \vec{r}_A \\ &= -\dot{\omega} \hat{k} \times L \hat{i} - \omega^2 L \hat{i} = -\dot{\omega} L \hat{j} - \omega^2 L \hat{i} \\ &= -2 \text{ rad/s} \cdot 2 \text{ ft} \hat{j} - (4 \text{ rad/s})^2 \cdot 2 \text{ ft} \hat{i} \\ &= -(4\hat{j} + 32\hat{i}) \text{ ft/s}^2. \end{aligned}$$

$$\vec{a}_A = -(4\hat{j} + 32\hat{i}) \text{ ft/s}^2$$

- (ii) The relative acceleration of point B with respect to point A is found by considering the motion of B with respect to A. Since both the points are on the same rigid body, point B executes circular motion with respect to point A. Therefore,

$$\begin{aligned} \vec{a}_{B/A} &= \dot{\vec{\omega}} \times \vec{r}_{B/A} + \vec{\omega} \times (\vec{\omega} \times \vec{r}_{B/A}) = \dot{\vec{\omega}} \times \vec{r}_{B/A} - \omega^2 \vec{r}_{B/A} \\ &= -\dot{\omega} \hat{k} \times L \hat{j} - \omega^2 L \hat{j} \\ &= \dot{\omega} L \hat{i} - \omega^2 L \hat{j} = 2 \text{ rad/s}^2 \cdot 2 \text{ ft} \hat{i} - (4 \text{ rad/s})^2 \cdot 2 \text{ ft} \hat{j} \\ &= (4\hat{i} - 32\hat{j}) \text{ ft/s}^2, \end{aligned}$$

and

$$\vec{a}_B = \vec{a}_A + \vec{a}_{B/A} = (-28\hat{i} - 36\hat{j}) \text{ ft/s}^2.$$

$$\vec{a}_B = -(28\hat{i} + 36\hat{j}) \text{ ft/s}^2$$

- (iii) Since point B is going in circles of radius OB about point O, we can find the acceleration of B as follows.

$$\begin{aligned} \vec{a}_B &= \dot{\vec{\omega}} \times \vec{r}_B + \vec{\omega} \times (\vec{\omega} \times \vec{r}_B) \\ &= \dot{\vec{\omega}} \times \vec{r}_B - \omega^2 \vec{r}_B \\ &= -\dot{\omega} \hat{k} \times (L \hat{i} + L \hat{j}) - \omega^2 (L \hat{i} + L \hat{j}) \\ &= (-\dot{\omega} L - \omega^2 L) \hat{j} + (\dot{\omega} L - \omega^2 L) \hat{i} \\ &= (-4 - 32) \text{ ft/s}^2 \hat{j} + (4 - 32) \text{ ft/s}^2 \hat{i} \\ &= (-36\hat{j} - 28\hat{i}) \text{ ft/s}^2. \end{aligned}$$

This acceleration is, naturally again, the same acceleration as found in (ii) above.

$$\vec{a}_B = -(28\hat{i} + 36\hat{j}) \text{ ft/s}^2$$

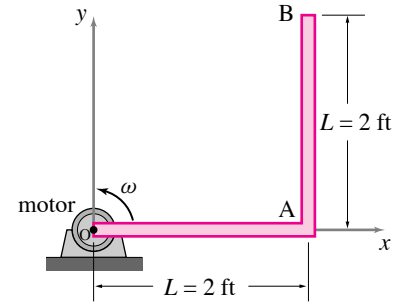

Figure 13.40: The ‘L’ shaped bar is rotating counterclockwise and is slowing down.

Filename:fig5-3-2a

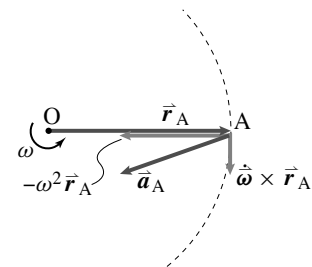

Figure 13.41:

Filename:fig5-3-2b

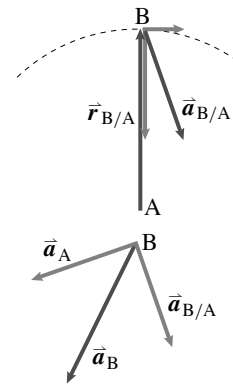

Figure 13.42:

Filename:fig5-3-2c

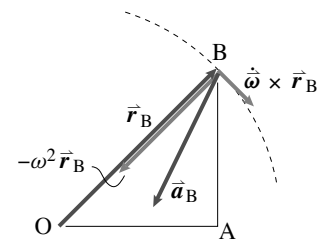

Figure 13.43:

Filename:fig5-3-2d

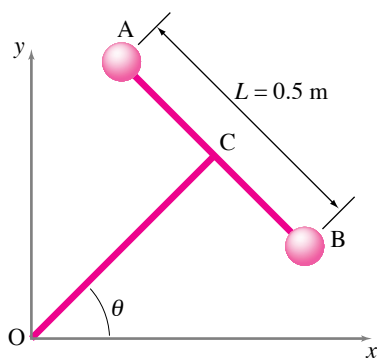

Figure 13.44:

Filename:fig5-3-3

SAMPLE 13.14 Relative velocity and acceleration: The dumbbell AB shown in the figure rotates counterclockwise about point O with angular acceleration 3 rad/s^2 . Bar AB is perpendicular to bar OC. At the instant of interest, $\theta = 45^\circ$ and the angular speed is 2 rad/s .

1. Find the velocity of point B relative to point A. Will this relative velocity be different if the dumbbell were rotating at a *constant* rate of 2 rad/s ?
2. Without calculations, draw a vector approximately representing the acceleration of B relative to A.
3. Find the acceleration of point B relative to A. What can you say about the direction of this vector as the motion progresses in time?

Solution

1. Velocity of B relative to A:

$$\begin{aligned}
 \vec{v}_{B/A} &= \vec{\omega} \times \vec{r}_{B/A} \\
 &= \dot{\theta} \hat{k} \times L(\sin \theta \hat{i} - \cos \theta \hat{j}) \\
 &= \dot{\theta} L(\sin \theta \hat{j} + \cos \theta \hat{i}) \\
 &= 2 \text{ rad/s} \cdot 0.5 \text{ m}(\sin 45^\circ \hat{j} + \cos 45^\circ \hat{i}) \\
 &= 0.707 \text{ m/s}(\hat{i} + \hat{j}).
 \end{aligned}$$

Thus the relative velocity is perpendicular to AB, that is, parallel to OC.

No, the relative velocity will not be any different at the instant of interest if the dumbbell were rotating at constant rate. As is evident from the formula, the relative velocity only depends on $\vec{\omega}$ and $\vec{r}_{B/A}$, and not on $\dot{\omega}$. Therefore, $\vec{v}_{B/A}$ will be the same if at the instant of interest, $\vec{\omega}$ and $\vec{r}_{B/A}$ are the same.

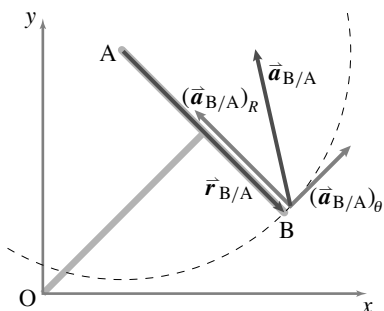

Figure 13.45: To draw the relative acceleration of B, $\vec{a}_{B/A}$, consider point B going in circles about point A.

Filename:fig5-3-3a

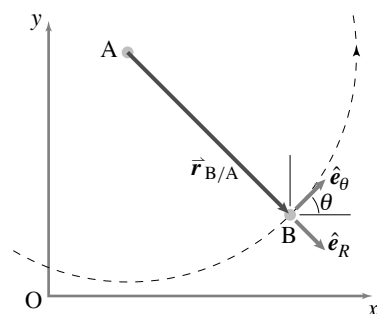

Figure 13.46: The geometry of \hat{e}_R and \hat{e}_θ for the imagined motion of B about A. $\hat{e}_R = \sin \theta \hat{i} - \cos \theta \hat{j}$ and $\hat{e}_\theta = \cos \theta \hat{i} + \sin \theta \hat{j}$.

Filename:fig5-3-3b

2. **Relative acceleration vector:** The velocity and acceleration of some point B on a rigid body *relative* to some other point A on the same body is the same as the velocity and acceleration of B if the body is considered to rotate about point A with the same angular velocity and acceleration as given. Therefore, to find the relative velocity and acceleration of B, we take A to be the center of rotation and draw the circular path of B, and then draw the velocity and acceleration vectors of B.

Since we know that the acceleration of a point under circular motion has tangential ($\dot{\omega} \times \vec{r}$ or $\dot{\theta} R \hat{e}_\theta$ in 2-D) and radial or centripetal ($\vec{\omega} \times (\vec{\omega} \times \vec{r})$ or $-\dot{\theta}^2 R \hat{e}_R$ in 2-D) components, the total acceleration being the vector sum of these components, we draw an approximate acceleration vector of point B as shown in Fig. 13.45.

3. Acceleration of B relative to A:

$$\begin{aligned}
 \vec{a}_{B/A} &= \dot{\vec{\omega}} \times \vec{r}_{B/A} + \vec{\omega} \times (\vec{\omega} \times \vec{r}_{B/A}) \\
 &= \ddot{\theta} \hat{k} \times L \hat{e}_R + \dot{\theta} \hat{k} \times (\dot{\theta} \hat{k} \times L \hat{e}_R) \\
 &= L \ddot{\theta} \hat{e}_\theta - L \dot{\theta}^2 \hat{e}_R \\
 &= 0.5 \text{ m} \cdot 3 \text{ rad/s}^2(\cos 45^\circ \hat{i} + \sin 45^\circ \hat{j}) \\
 &\quad - 0.5 \text{ m} \cdot (2 \text{ rad/s})^2(\sin 45^\circ \hat{i} - \cos 45^\circ \hat{j}) \\
 &= 1.061 \text{ m/s}^2(\hat{i} + \hat{j}) - 1.414 \text{ m/s}^2(\hat{i} - \hat{j}) \\
 &= (-0.353 \hat{i} + 2.474 \hat{j}) \text{ m/s}^2.
 \end{aligned}$$

$$\vec{a}_{B/A} = (-0.353\hat{i} + 2.474\hat{j}) \text{ m/s}^2$$

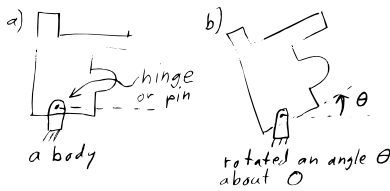

Figure 13.47: a) A object, b) rotated counterclockwise an angle θ about O.

Filename: tfigure-circmot2D

Rotating 2D rigid body

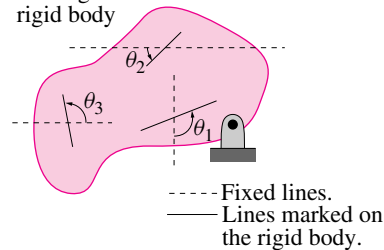

Figure 13.48: **Rotation of lines on a rotating rigid object.** Some real or imagined lines marked on the rigid object are shown. They make the angles $\theta_1, \theta_2, \theta_3, \dots$ with respect to various fixed lines which do not rotate. As the object rotates, each of these angles increases by the same amount.

Filename: tfigure4-2Domega

① The word axis is obviously related to the word axle. More generally the word axis means 'line'. For example the x and y axes are generally not axes about which anything rotates.

13.4 Kinematics of a rigid object in planar circular motion

When two parts are glued together or attached by welding, gluing, several tight screws, bolts, rivets bolts or the like we call the connection a 'rigid attachment'. And, for the purposes of mechanics analysis, the two connected parts make up one bigger object. But most machines have various parts that are connected to each other, but not welded to each other. The most common such non-rigid attachment in engineering is a hinge. In 2D,

a hinge attachment between two objects keeps two points, one from each object, on top of each other while freely allowing relative rotation of the two objects about the hinge point.

In 3D a hinge keeps two lines, one on each body, coincident and allows relative rotation about that line. The common line, or in 2D the line orthogonal to the plane through the points, is called the hinge, the hinge axis, or the axis of rotation.

One example of a hinge is a car axle which allows rotation of a wheel relative to the car suspension. The hinge axis is the axle^①. Hinges are made various ways, sometimes by poking a cylindrical pin through the two objects and sometimes with ball bearings (see box ?? on page ??). So hinges are also called *pin connections* or *bearings* (Fig. 13.47). In this chapter we limit our attention to a simple use of a hinge: one rigid part is hinged to a part that doesn't move. Such a non-moving part can be thought of as connected to the ground or 'fixed frame'. In this simple case one point on the moving part does not move and the rest of the part rotates about that point.

For definiteness and simplicity let's call the hinge location O and the hinge axis through O the z axis. One function of the hinge is to make the part's only possible motion to be rotation about O . Thus to understand the dynamics of a hinged part we need to understand the position, velocity and acceleration of points on a rigid object which rotates. This whole section is about the kinematics (the geometry of motion) for this rotation. We will measure the amount of rotation by the angle θ , and the rate of rotation θ by the *angular velocity* $\vec{\omega}$ ('omega'), and of rate of change of this angular velocity $\vec{\omega}$ by the *angular acceleration* $\vec{\alpha}$ ('alpha').

As simple as this topic seems at first glance, you should pay close attention to the meanings and uses of these quantities. The rest of the book completely depends on the material in this section.

Rotation of an object counterclockwise by θ

We start by imagining the object in a distinguished configuration which we call the *reference configuration*, *reference state* or *reference position*. For example we could take the left figure in *Fig. 13.47* as the reference configuration. If possible its usually best to pick the reference state to be one in which a prominent feature of the object is aligned with the x or y axes. The reference state may or may not be the start of the motion of interest. Even if not, we measure an object's rotation by the change, relative to the reference state, in the counterclockwise angle θ of a reference line marked in the object relative to a fixed line outside. Which reference line? Fortunately,

All real or imagined lines marked on a rotating rigid object rotate by the same angle, the rotation angle, θ . (See box 13.3).

13.3 THEORY

Rotation is uniquely defined for a rigid object (2D)

Most people will find it self-evident that, starting with a rigid object at a reference orientation, all lines marked on the object rotate by the same angle θ . Here, for the doubting, we demonstrate this fact.

A rigid object is defined this way:

For every pair of material points A and B on a rigid object the distance $|AB|$ between them does not change as the object moves.

In particular, when a rigid object rotates all distances between pairs of points are preserved. Thus, by the "side-side-side" similar triangle theorem of elementary geometry, all relative angles between marked line segments are preserved by the rotation. For example, for a triangle ABC the angle at B is constant as the object rotates. Now consider any pair of line segments on the object.

[By 'on' the object we don't mean a projected image drawn with a light pen that can move around on the object relative to the atoms. Rather, by 'on the object' we mean something defined by a particular set of atoms that make up the object.]

If the segments do not cross we can extend them to a point of intersection B. Such a pair of intersecting lines is shown here before and after rotation.

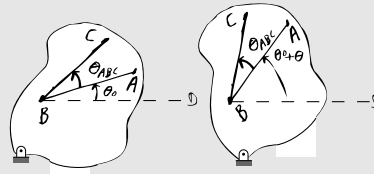

Initially BA makes an angle θ_0 with a horizontal reference line. BC then makes an angle of $\theta_{ABC} + \theta_0$. After rotation we measure the angle to the line BD (displaced in a parallel manner). BA now makes an angle of $\theta_0 + \theta$ where θ is the angle of rotation of the object. By the addition of angles in the rotated configuration line BC now makes an angle of $\theta_{ABC} + \theta_0 + \theta$ which makes an increase by θ of the angle made by BC with the horizontal reference line. So both BA and VC rotate by the same angle θ .

We could use one of these two lines and compare it with an arbitrary third line through B and show that the third line also has equal rotation, and then a fourth, and so on. So all lines on the object through a point B rotate by the same angle θ . The demonstration for a pair of parallel lines, one of them through B, is easy, they stay parallel so always make a common angle with any reference line.

Any line on the object either goes through B or is parallel to a line through B. So all lines marked on a rigid object rotate by the same angle θ .

The rotation of a rigid object in 2D is thus unambiguously defined as *the* angle through which all lines on the object rotate.

In three dimensions things are more complicated. General rotation of a rigid object is then represented not with a single angle θ , but rather with 3 angles, or with a unit vector and an angle, or a 3×3 matrix. So we wait to discuss which of the 2D ideas here generalize to 3D and which do not.

Rotated coordinates and base vectors \hat{i}' and \hat{j}'

We pick two orthogonal lines on the rotating object and give them distinguished status as *object-fixed* (or *body-fixed*) rotating coordinate axes x' and y' . Think of these axes as $x'y'$ coordinate axes on a piece of graph paper that is glued to the object. Its easiest if we start by assuming that the $x'y'$ axes have the same origin O as the xy axes and are parallel with the fixed xy axes when the object is in the reference configuration (when $\theta = 0$).

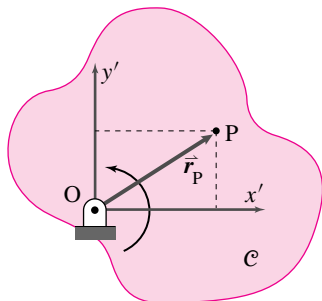

Figure 13.49: A rotating rigid object C with rotating coordinates $x'y'$ rigidly attached.

Filename:figure4-intro-rot-frames

These rotating coordinate axes, x' and y' , have associated rotating base vectors \hat{i}' and \hat{j}' (Fig. 13.49 and 13.50). So \hat{i}' is always in the x' direction and \hat{j}' always in the y' direction. We will use these rotating coordinates and base vectors to keep track of a some particle of interest P that is ‘glued’ to the object. To start not that particle P glued to the object has x' and y' coordinates that don’t change as the rotation progresses.

Example: **A particle on the x' axis**

If a particle P is fixed on the x' -axis at position $x' = 3$ cm, then we have.

$$\vec{r}_P = 3\text{ cm}\hat{i}'$$

for all time, even as the object rotates.

The position vector of a point P fixed to a rigid object hinged at O remains, as the rotation progresses,

$$\vec{r}_P = x'\hat{i}' + y'\hat{j}', \tag{13.21}$$

$$\tag{13.22}$$

with x' and y' both constant. These rotating coordinate system components, $[\vec{r}]_{x'y'} = [x', y']$, are sometimes written as $[\vec{r}]_{x'y'} = \begin{bmatrix} x' \\ y' \end{bmatrix}$.

You will see that much of the math for rotating $x'y'$ coordinates is reminiscent of that for polar coordinates. However, the spirit is a bit different. In polar coordinates the \hat{e}_r axes was picked to track a particular particle of interest. Here we pick axes that rotate with an extended object and use that one set of axes to track any and all particles of interest.

Note, even though neither x' nor y' change as θ changes, the point P they describe moves, in circles actually. How can the particle’s position change if its coordinates don’t change? Well, in eqn. (13.23) the change in position is represented by the base vectors changing as

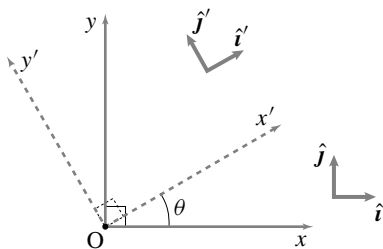

Figure 13.50: Fixed coordinate axes and rotating coordinate axes.

Filename:figure4-1-rot-coord

the object rotates. Thus we could write more explicitly that

$$\vec{r}_P = x' \hat{i}' + y' \hat{j}'(\theta). \quad (13.23)$$

Here we show more explicitly that the base vectors \hat{i}' and \hat{j}' depend on θ . Just like for polar base vectors (see *eqn.* (13.4) on page 6) we can express the rotating base vectors in terms of the fixed base vectors and θ .

$$\begin{aligned} \hat{i}' &= \cos \theta \hat{i} + \sin \theta \hat{j}, \\ \hat{j}' &= -\sin \theta \hat{i} + \cos \theta \hat{j}. \end{aligned} \quad (13.24)$$

Also we can express the fixed basis vectors in terms of the rotating vectors like this:

$$\begin{aligned} \hat{i} &= \cos \theta \hat{i}' - \sin \theta \hat{j}' \\ \hat{j} &= \sin \theta \hat{i}' + \cos \theta \hat{j}'. \end{aligned} \quad (13.25)$$

Please review the section on dot products, ??, to see one derivation of these formulae.

We will use the phrase *reference frame* or just *frame* to mean “a coordinate system attached to a rigid object”. One can think of the coordinate grid as like an invisible metal framework (hence the word ‘frame’) that rotates with the object. We refer to a calculation based on the rotating coordinates in *Fig.* 13.49 variously as “in the frame \mathcal{C} ” or “using the $x'y'$ frame” or “in the $\hat{i}'\hat{j}'$ frame”^②.

In computer calculations we usually manipulate lists and arrays of numbers and not geometric vectors. So on a computer we keep track of vectors by keeping track of their lists of components. Lets look at a point fixed to the object and whose coordinates we know in the reference configuration:

$$\left[\vec{r}_P^{\text{ref}} \right]_{xy} = \begin{bmatrix} x^{\text{ref}} \\ y^{\text{ref}} \end{bmatrix}.$$

Assuming the object axes and fixed axes coincide in the reference configuration, the object coordinates of a point $\left[\vec{r}_P \right]_{x'y'}$ are equal to the space fixed coordinates of the point in the reference configuration $\left[\vec{r}_P^{\text{ref}} \right]_{xy}$. We can think of the point as defined either way, so

$$\left[\vec{r}_P \right]_{x'y'} = \left[\vec{r}_P^{\text{ref}} \right]_{xy}.$$

The rotation matrix $[R]$

Here is a question we often need to answer: What are the fixed basis coordinates of a point that has the rotating-frame coordinates $\left[\vec{r} \right]_{x'y'} =$

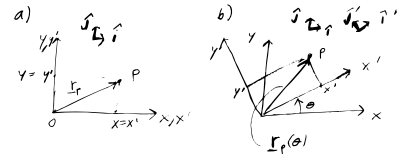

Figure 13.51: The x' and y' coordinates of a point fixed on a rotating object stay constant while the base vectors \hat{i}' and \hat{j}' rotate with the object.

Filename:figure-rotatepbytheta

② Advanced aside. Sometimes a *reference frame* is defined as the set of all coordinate systems that could be attached to a rigid object. Two coordinate systems, even if rotated with respect to each other, then represent the same frame so long as they rotate together. Some of the results we will develop only depend on this more slack definition of frame, that the coordinates are glued to the object with no mind of their orientation in the reference configuration.

$\begin{bmatrix} x' \\ y' \end{bmatrix}$? Here is one way to find the answer:

$$\begin{aligned} \vec{r}_P &= x'\hat{i}' + y'\hat{j}' \\ &= x'(\cos\theta\hat{i} + \sin\theta\hat{j}) + y'(-\sin\theta\hat{i} + \cos\theta\hat{j}) \\ &= \underbrace{((\cos\theta)x' - (\sin\theta)y')}_x \hat{i} + \underbrace{((\sin\theta)x' + (\cos\theta)y')}_y \hat{j} \end{aligned} \quad (13.26)$$

so we can pull out the x and y coordinates compactly as,

$$[\vec{r}_P]_{xy} = \begin{bmatrix} x \\ y \end{bmatrix} = \begin{bmatrix} \cos\theta & \sin\theta \\ \sin\theta & \cos\theta \end{bmatrix} \begin{bmatrix} x' \\ y' \end{bmatrix}. \quad (13.27)$$

But this can, in turn be written in matrix notation as

$$\begin{aligned} \begin{bmatrix} x \\ y \end{bmatrix} &= \underbrace{\begin{bmatrix} \cos\theta & -\sin\theta \\ \sin\theta & \cos\theta \end{bmatrix}}_{\equiv [R]} \begin{bmatrix} x' \\ y' \end{bmatrix}, \quad \text{or} \\ [\vec{r}_P]_{xy} &= [R][\vec{r}_P]_{x'y'}. \quad \text{or} \\ [\vec{r}_P]_{xy} &= [R][\vec{r}_P^{\text{ref}}]_{x'y'}, \end{aligned} \quad (13.28)$$

The matrix $[R]$ or $[R(\theta)]$ is the *rotation matrix* for counterclockwise rotations by θ . As shown above, if you know the coordinates of a point fixed on an object before rotation, you can find its coordinates after rotation by multiplying the coordinate column vector by the matrix $[R]$. You can remember what $[R]$ is by remembering its components or by remembering that

the first and second column of $[R]$ are the components of \hat{i}' and \hat{j}' , respectively, in the fixed coordinate system.

For example, the first column of $[R]$ consist of the x and y components of \hat{i}' . A feature of *eqn.* (13.28) is that the same matrix $[R]$ prescribes the coordinate change for every different point on the object. Thus for points called 1, 2 and 3 we have

$$\begin{bmatrix} x_1 \\ y_1 \end{bmatrix} = [R] \begin{bmatrix} x'_1 \\ y'_1 \end{bmatrix}, \quad \begin{bmatrix} x_2 \\ y_2 \end{bmatrix} = [R] \begin{bmatrix} x'_2 \\ y'_2 \end{bmatrix} \quad \text{and} \quad \begin{bmatrix} x_3 \\ y_3 \end{bmatrix} = [R] \begin{bmatrix} x'_3 \\ y'_3 \end{bmatrix}.$$

A more compact way to write a matrix times a list of column vectors is to arrange the column vectors one next to the other in a matrix. By multiplying this matrix by $[R]$ we get a new matrix whose columns are the new coordinates of various points. For example,

$$\begin{bmatrix} x_1 & x_2 & x_3 \\ y_1 & y_2 & y_3 \end{bmatrix} = [R] \begin{bmatrix} x'_1 & x'_2 & x'_3 \\ y'_1 & y'_2 & y'_3 \end{bmatrix}. \quad (13.29)$$

Eqn. 13.29 is useful for computer animation of rotating things in video games (and in dynamics simulations too) where points 1,2, and 3 are points on an object.

Example: Rotate a picture

If a simple picture of a house is drawn by connecting the six points (*Fig. 13.52a*) with the first point at $(x, y) = (1, 2)$, the second at $(x, y) = (3, 2)$, etc., and the sixth point on top of the first, we have,

$$[xy \text{ points BEFORE}] \equiv \begin{bmatrix} 1 & 3 & 3 & 2 & 1 & 1 \\ 2 & 2 & 4 & 5 & 4 & 2 \end{bmatrix}.$$

After a 30° counter-clockwise rotation about O, the coordinates of the house, in a coordinate system that rotates with the house, are unchanged (*Fig. 13.52b*). But in the fixed (non-rotating, Newtonian) coordinate system the new coordinates of the rotated house points are,

$$\begin{aligned} [xy \text{ points AFTER}] &= [\mathbf{R}][xy \text{ points BEFORE}] = [\mathbf{R}][x'y' \text{ points}] \\ &= \begin{bmatrix} \sqrt{3}/2 & -.5 \\ .5 & \sqrt{3}/2 \end{bmatrix} \begin{bmatrix} 1 & 3 & 3 & 2 & 1 & 1 \\ 2 & 2 & 4 & 5 & 4 & 2 \end{bmatrix} \\ &\approx \begin{bmatrix} -0.1 & 1.6 & 0.6 & -0.8 & -1.1 & -0.1 \\ 2.2 & 3.2 & 5.0 & 5.3 & 4.0 & 2.2 \end{bmatrix} \end{aligned}$$

as shown in *Fig. 13.52c*.

Angular velocity of a rigid object: $\vec{\omega}$

Thus far we have talked about rotation, but not how it varies in time. Dynamics is about motion, velocities and accelerations, so we need to think about rotation rates and rotational accelerations.

A 2D rigid object's net rotation is measured by the rotation angle θ . Thus, the simplest measure of rotation rate is $\dot{\theta} \equiv \frac{d\theta}{dt}$. Because all marked lines rotate the same amount θ they all have the same rates of change. So $\dot{\theta}_1 = \dot{\theta}_2 = \dot{\theta}_3 = \text{etc.}$ So, as for rotation, the concept of rotation rate of a rigid object transcends the concept of rotation rate of this or that particular line. We give this rotation rate of a rigid object a special name, *angular velocity*, and symbol, ω (omega).

Repeating, for all lines marked on a rigid object,

$$\omega \equiv \dot{\theta}_1 = \dot{\theta}_2 = \dot{\theta}_3 = \dots = \dot{\theta}. \quad (13.30)$$

Often we think of angular velocity as a vector $\vec{\omega}$. Its direction is the axis of the rotation which, for objects in the xy plane is \hat{k} pointed along the z axis. The scalar part of $\vec{\omega}$ is ω . So, the *angular velocity vector* is

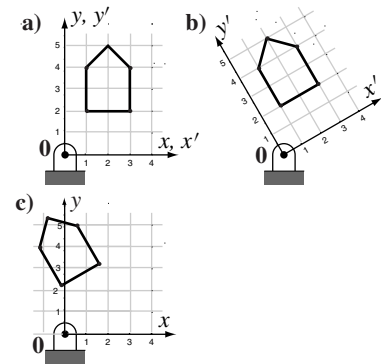

Figure 13.52: a) A house is drawn by connecting lines between 6 points, b) the house and coordinate system are rotated, thus its coordinates in the rotating system do not change c) But the coordinates in the original system do change

Filename: tfigure-rotatedhouse

$$\vec{\omega} \equiv \omega \hat{k} \tag{13.31}$$

with ω as defined in eqn. (13.30). Note $\vec{\omega}$ is the angular velocity of the object (and of every line on it).

Rate of change of \hat{i}' , \hat{j}'

Our first use of the angular velocity vector $\vec{\omega}$ is to calculate the rate of change of the rotating unit base vectors \hat{i}' and \hat{j}' . We can find the rate of change of, say, \hat{i}' , by taking the time derivative of the first of eqn. (13.24), and using the chain rule while recognizing that $\theta = \theta(t)$. We can also make an analogy with polar coordinates (page 5), where we think of \hat{e}_R as like \hat{i}' and \hat{e}_θ as like \hat{j}' . We found there that $\dot{\hat{e}}_\theta = \theta \hat{e}_R$ and $\dot{\hat{e}}_R = -\theta \hat{e}_\theta$. Either way,

$$\begin{aligned} \dot{\hat{i}}' &= \dot{\theta} \hat{j}' & \text{or} & & \dot{\hat{j}}' &= \vec{\omega} \times \hat{i}' & \text{and} \\ \dot{\hat{j}}' &= -\dot{\theta} \hat{i}' & \text{or} & & \dot{\hat{j}}' &= \vec{\omega} \times \hat{j}' \end{aligned} \tag{13.32}$$

because $\hat{j}' = \hat{k}' \times \hat{i}'$ and $\hat{i}' = -\hat{k}' \times \hat{j}'$. Depending on the tastes of your lecturer, you may find eqn. (13.32) one of the most used equations from this point onward^③.

^③Eqn. 13.32 is sometimes considered the definition of $\vec{\omega}$. In this view, $\vec{\omega}$ is that vector which determines $\dot{\hat{i}}'$ and $\dot{\hat{j}}'$ by the formulas $\dot{\hat{i}}' = \vec{\omega} \times \hat{i}'$ and $\dot{\hat{j}}' = \vec{\omega} \times \hat{j}'$. Then one needs to show that such a vector exists and that it is $\vec{\omega} = \hat{i}' \times \dot{\hat{i}}'$. Luckily this is the same as our $\vec{\omega} = \dot{\theta} \hat{k}$.

13.4 The fixed Newtonian reference frame \mathcal{F}

Now we can reconsider the concept of a Newtonian frame, a concept which we had to assume to write the equations of dynamics in the first place. All of mechanics depends, of course, on the laws of mechanics. The laws of mechanics are equations which involve, in part, the positions of things as a function of time. But how position is perceived to change in time depends on your reference frame. And some reference frames are better than others. The best, from our point of view, are reference frames in which Newton's laws are accurate. Such a reference frame is called a *Newtonian frame*. In engineering practice the frames we use as approximations of a Newtonian frame often seem, loosely speaking, somehow still. So we sometimes call such a frame *the fixed frame* and label it with a script capital \mathcal{F} . When we talk about velocity and acceleration of mass points, for use in the equations of mechanics, we are always talking about the velocity and acceleration relative to a \mathcal{F} ixed, or equivalently, Newtonian frame.

Assume x and y are the coordinates of a vector \vec{r}_P and \mathcal{F} is a fixed frame with fixed axis (with associated

constant base vectors \hat{i} and \hat{j}). When we write $\dot{\vec{r}}_P$ we mean $\dot{x}\hat{i} + \dot{y}\hat{j}$. But we could be more explicit (and notationally ornate) and write the velocity of P in the Newtonian frame as

$$\frac{\mathcal{F}d\vec{r}_P}{dt} \equiv \frac{\mathcal{F}\dot{\vec{r}}_P}{dt} \text{ by which we mean } \dot{x}\hat{i} + \dot{y}\hat{j}.$$

The \mathcal{F} in front of the time derivative (or in front of the dot) means that when we calculate a derivative we hold the base vectors of \mathcal{F} constant. This is no surprise, because for \mathcal{F} the base vectors *are* constant. In general, however, when taking a derivative in a given frame you

- write vectors in terms of base vectors stuck to the frame, and
- only differentiate the components.

We will avoid the ornate notation of labeling frames when it is not needed. For example, if you don't see any script capital letters floating around in front of derivatives, you can assume that we are taking derivatives relative to a fixed Newtonian frame.

Velocity of a point fixed on a rigid object

Lets call some rotating object \mathcal{B} (script capital B) to which is glued a coordinate system $x'y'$ with base vectors \hat{i}' and \hat{j}' . We now introduce the concept of *derivative in a frame* which we write, for the frame \mathcal{B} , as

$$\frac{\mathcal{B}d}{dt}$$

which means, in words, the rate of change of something as viewed in the rotating frame \mathcal{B} . Now consider a point P at \vec{r}_P that is glued to the object. That is, the x' and y' coordinates of \vec{r}_P do not change in time.

$$\frac{\mathcal{B}d\vec{r}_P}{dt} \equiv \dot{\vec{r}}_P = \dot{x}'\hat{i}' + \dot{y}'\hat{j}' = \vec{0}.$$

That is, relative to a moving frame, the velocity of a point glued to the frame is zero (no surprise).

We would like to know the velocity of such a point in the fixed frame. We just take the derivative, using the product rule and the differentiation rules we have developed for the rotating base vectors:

$$\begin{aligned} \vec{r}_P &= x'\hat{i}' + y'\hat{j}' \\ \Rightarrow \vec{v}_P = \dot{\vec{r}}_P &= \frac{d}{dt}(x'\hat{i}' + y'\hat{j}') = x'\dot{\hat{i}}' + y'\dot{\hat{j}}' = x'(\vec{\omega} \times \hat{i}') + y'(\vec{\omega} \times \hat{j}') \\ &= \vec{\omega} \times (x'\hat{i}' + y'\hat{j}') \end{aligned}$$

where $\dot{\vec{r}}_P$ is the simple way to write $\frac{\mathcal{F}d\vec{r}_P}{dt}$. Thus,

$$\vec{v}_P = \vec{\omega} \times \vec{r}_P \quad (13.33)$$

We can rewrite eqn. (13.33) in a minimalist or elaborate notation, both are correct, as

$$\begin{aligned} \vec{v} &= \vec{\omega} \times \vec{r} \quad \text{or} \\ \frac{\mathcal{F}d\vec{r}_P}{dt} &= \vec{\omega}_{\mathcal{B}/\mathcal{F}} \times \vec{r}_{P/O}. \end{aligned}$$

In the first case you have to use common sense to know what point you are talking about and that it is on a object rotating with absolute angular velocity $\vec{\omega}$. In the second case everything is laid out perfectly clearly (which is why it looks so confusing). On the left side of the equation it says that we are interested in how point P moves relative to, not just any frame, but the fixed frame \mathcal{F} . On the right side we make clear that the rotation rate we are looking at is that of object \mathcal{B} relative to \mathcal{F} and not some other relative rotation. We further make clear that the formula only makes sense if the position of the point P is measured relative to a point which doesn't move, namely O.

What we have just found largely duplicates what we already learned in section 7.1 for points moving in circles. The slight generalization is

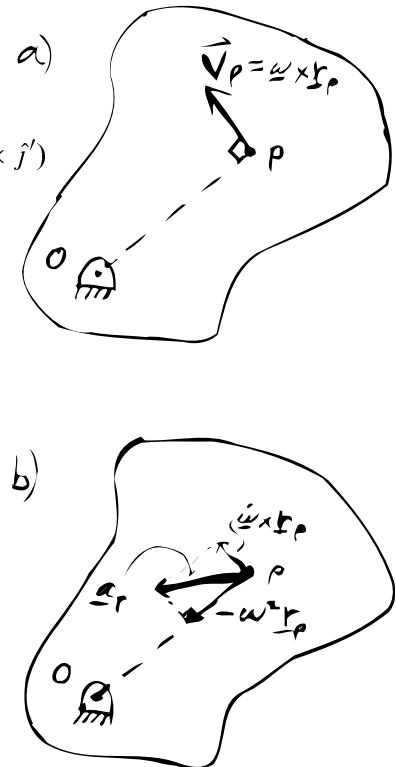

Figure 13.53: Velocity and acceleration of two points on a rigid object rotating about O.

Filename:figure-velandacceloP

that the same angular velocity $\vec{\omega}$ can be used to calculate the velocities of multiple points on one rigid object. But the key idea remains: the velocity of a point going in circles is tangent to the circle it is going around and with magnitude proportional both to distance from the center and the angular rate of rotation (*Fig. 13.53a*).

Acceleration of a point on a rotating rigid object

Let's again consider a point stuck on a rotating object and with position

$$\vec{r}_P = x'i' + y'j'.$$

Relative to the frame \mathcal{B} to which a point is attached, its acceleration is zero (again no surprise). But what is its acceleration in the fixed frame? We find this by writing the position vector and then differentiating twice, repeatedly using the product rule and *eqn. (13.32)*.

Leaving off the ornate pre-super-script \mathcal{F} for simplicity, we have

$$\begin{aligned} \vec{a}_P = \dot{\vec{v}}_P &= \frac{d}{dt} \left(\frac{d}{dt} (x'i' + y'j') \right) \\ &= \frac{d}{dt} (x'(\vec{\omega} \times i') + y'(\vec{\omega} \times j')). \end{aligned} \quad (13.34)$$

To continue we need to use the product rule of differentiation for the cross product of two time dependent vectors like this:

$$\begin{aligned} \frac{d}{dt} (\vec{\omega} \times i') &= \dot{\vec{\omega}} \times i' + \vec{\omega} \times \dot{i}' = \dot{\vec{\omega}} \times i' + \vec{\omega} \times (\vec{\omega} \times i'), \\ \frac{d}{dt} (\vec{\omega} \times j') &= \dot{\vec{\omega}} \times j' + \vec{\omega} \times \dot{j}' = \dot{\vec{\omega}} \times j' + \vec{\omega} \times (\vec{\omega} \times j'). \end{aligned} \quad (13.35)$$

Substituting back into *eqn. (13.34)* we get

$$\begin{aligned} \vec{a}_P &= \left(x'(\dot{\vec{\omega}} \times i' + \vec{\omega} \times (\vec{\omega} \times i')) + y'(\dot{\vec{\omega}} \times j' + \vec{\omega} \times (\vec{\omega} \times j')) \right) \\ &= \dot{\vec{\omega}} \times (x'i' + y'j') + \vec{\omega} \times (\vec{\omega} \times (x'i' + y'j')) \\ &= \dot{\vec{\omega}} \times \vec{r}_P + \vec{\omega} \times (\vec{\omega} \times \vec{r}_P) \end{aligned} \quad (13.36)$$

④ Although the form *eqn. (13.36)* is not of much immediate use, if you are going to continue on to the mechanics of mechanisms or three dimensional mechanics, you should follow the derivation of *eqn. (13.36)* carefully.

which is hardly intuitive at a glance^④. Recalling that in 2D $\vec{\omega} = \omega \hat{k}$ we can use either the right hand rule or manipulation of unit vectors to rewrite *eqn. (13.36)* as

$$\vec{a}_P = \dot{\omega} \hat{k} \times \vec{r}_P - \omega^2 \vec{r}_P \quad (13.37)$$

where $\omega = \dot{\theta}$ and $\dot{\omega} = \ddot{\theta}$.

Thus, as we found in section 13.1 for a particle going in circles, the acceleration can be written as the sum of two terms, a tangential acceleration $\dot{\omega} \hat{k} \times \vec{r}_P$ due to increasing tangential speed, and a centrally

directed (centripetal) acceleration $-\omega^2 \vec{r}_P$ due to the direction of the velocity continuously changing towards the center (see *Fig. 13.53b*). The generalization we have made in this section is that the same $\vec{\omega}$ can be used to calculate the acceleration for all the different points on one rotating object. A second brief derivation of the acceleration eqn. (13.37) goes like this (using minimalist notation):

$$\begin{aligned}\vec{a} &= \dot{\vec{v}} = \frac{d}{dt}(\vec{\omega} \times \vec{r}) \\ &= \dot{\vec{\omega}} \times \vec{r} + \vec{\omega} \times \dot{\vec{r}} \\ &= \dot{\vec{\omega}} \times \vec{r} + \vec{\omega} \times (\vec{\omega} \times \vec{r}) \\ &= \dot{\vec{\omega}} \times \vec{r} - \omega^2 \vec{r}.\end{aligned}$$

Relative motion of points on a rigid object

As you well know by now, the position of point B relative to point A is $\vec{r}_{B/A} \equiv \vec{r}_B - \vec{r}_A$. Similarly the relative velocity and acceleration of two points A and B is defined to be

$$\vec{v}_{B/A} \equiv \vec{v}_B - \vec{v}_A \quad \text{and} \quad \vec{a}_{B/A} \equiv \vec{a}_B - \vec{a}_A \quad (13.38)$$

So, the relative velocity (as calculated relative to a fixed frame) of two points glued to one spinning rigid object \mathcal{B} is given by

$$\begin{aligned}\vec{v}_{B/A} &\equiv \vec{v}_B - \vec{v}_A \\ &= \vec{\omega} \times \vec{r}_{B/O} - \vec{\omega} \times \vec{r}_{A/O} \\ &= \vec{\omega} \times (\vec{r}_{B/O} - \vec{r}_{A/O}) \\ &= \vec{\omega} \times \vec{r}_{B/A},\end{aligned}$$

where point O is the point in the Newtonian frame on the fixed axis of rotation and $\vec{\omega} = \vec{\omega}_C$ is the angular velocity of \mathcal{C} . Repeating,

$$\vec{v}_{B/A} = \vec{\omega} \times \vec{r}_{B/A} \quad (13.39)$$

Because points A and B are fixed on \mathcal{B} their velocities and hence their relative velocity as observed in a reference frame fixed to \mathcal{C} is $\vec{0}$. But, point A has some absolute velocity that is different from the absolute velocity of point B. So they have a relative velocity as seen in the fixed frame. And it is what you would expect if B was just going in circles around A. Similarly, the relative acceleration of two points glued to one rigid object spinning at constant rate is

$$\vec{a}_{B/A} \equiv \vec{a}_B - \vec{a}_A = \dot{\vec{\omega}} \times \vec{r}_{B/A} + \vec{\omega} \times (\vec{\omega} \times \vec{r}_{B/A}). \quad (13.40)$$

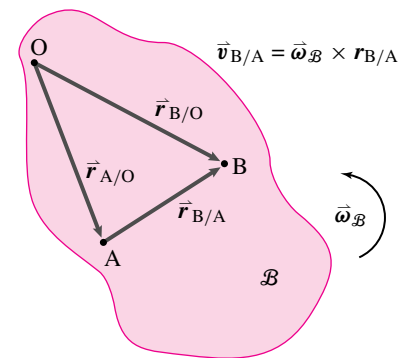

Figure 13.54: The acceleration of B relative to A if they are both on the same rotating rigid object.

Filename:figure4-vel-accel-rel

Again, the relative acceleration is due to the difference in the points' positions relative to the point O fixed on the axis. These kinematics results, 13.39 and 13.40, are useful for calculating angular momentum relative to the center-of-mass. They are also sometimes useful for the understanding of the motions of machines with moving connected parts.

The fundamental $\vec{\omega}$ equation

Eqn. 13.39,

$$\dot{\vec{r}}_{B/A} = \vec{\omega} \times \vec{r}_{B/A},$$

is the most fundamental equation of rigid-object kinematics. Know it well. For future reference, equation (13.39) is also valid in three dimensions. Now let's use it in various ways to calculate relative and absolute velocities and accelerations of various points.

Calculating relative velocity directly, using rotating frames

A coordinate system $x'y'$ to a rotating rigid object \mathcal{C} , defines a reference frame \mathcal{C} (Fig. 13.49). Recall, the base vectors in this frame change in time just like any other vector fixed in the rotating frame:

$$\frac{d}{dt}\hat{i}' = \vec{\omega}_C \times \hat{i}' \quad \text{and} \quad \frac{d}{dt}\hat{j}' = \vec{\omega}_C \times \hat{j}'.$$

If we now write the relative position of B to A in terms of \hat{i}' and \hat{j}' , we have

$$\vec{r}_{B/A} = x'\hat{i}' + y'\hat{j}'.$$

Since the coordinates x' and y' rotate with the object to which A and B are attached, they are constant with respect to that object,

$$\dot{x}' = 0 \quad \text{and} \quad \dot{y}' = 0.$$

So

$$\begin{aligned} \frac{d}{dt}(\vec{r}_{B/A}) &= \frac{d}{dt}(x'\hat{i}' + y'\hat{j}') \\ &= \underbrace{\dot{x}'}_0 \hat{i}' + x' \frac{d}{dt}\hat{i}' + \underbrace{\dot{y}'}_0 \hat{j}' + y' \frac{d}{dt}\hat{j}' \\ &= x'(\vec{\omega}_C \times \hat{i}') + y'(\vec{\omega}_C \times \hat{j}') \\ &= \vec{\omega}_C \times \underbrace{(x'\hat{i}' + y'\hat{j}')}_{\vec{r}_{B/A}} \\ &= \vec{\omega}_C \times \vec{r}_{B/A}. \end{aligned}$$

We could similarly calculate $\vec{a}_{B/A}$ by taking another derivative to get

$$\vec{a}_{B/A} = \vec{\omega}_C \times (\vec{\omega}_C \times \vec{r}_{B/A}) + \dot{\vec{\omega}}_C \times \vec{r}_{B/A}.$$

The concept of measuring velocities and accelerations relative to a rotating frame will be of interest when finding motions of machines with linked parts.

13.5 Plato's discussion of spinning in circles as motion (or not)

Plato imagines a discussion between Socrates and Glaucon about how an object can maintain contradictory attributes simultaneously:

“ Socrates: Now let's have a more precise agreement so that we won't have any grounds for dispute as we proceed. If someone were to say of a human being standing still, but moving his hands and head, that the same man at the same time stands still and moves, I don't suppose we'd claim that it should be said like that, but rather that one part of him stands still and another moves. Isn't that so?

Glaucon: Yes it is.

Socrates: Then if the man who says this should become still more charming and make the subtle point that tops as wholes stand still and move at the same time when

the peg is fixed in the same place and they spin, or that anything else going around in a circle on the same spot does this too, we wouldn't accept it because it's not with respect to the same part of themselves that such things are at the same time both at rest and in motion. But we'd say that they have in them both a straight and a circumference; and with respect to the straight they stand still since they don't lean in any direction –while with respect to the circumference they move in a circle; and when the straight inclines to the right the left, forward, or backward at the same time that it's spinning, then in no way does it stand still.

Glaucon: And we'd be right.”

This chapter is about things that are still with respect to their own parts (they do not distort) but in which the points do move in circles.

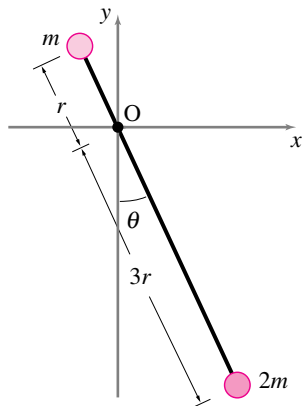

Figure 13.55:

Filename:fig4-5-1

SAMPLE 13.15 A pendulum is made up of two unequal point masses m and $2m$ connected by a massless rigid rod of length $4r$. The pendulum is pivoted at distance r along the rod from the small mass.

1. Find the moment of inertia I_{zz}^O of the pendulum.
2. If you had to put the total mass $3m$ at one end of the bar and still have the same I_{zz}^O as in (a), at what distance from point O should you put the mass? (This distance is known as the radius of gyration).

Solution Here we have two point masses. Therefore, the integral formula for I_{zz}^O ($I_{zz}^O = \int_m r^2 dm$) gets replaced by a summation over the two masses:

$$\begin{aligned} I_{zz}^O &= \sum_{i=1}^2 m_i r_{i/O}^2 \\ &= m_1 r_{1/O}^2 + m_2 r_{2/O}^2 \end{aligned}$$

1. For the pendulum, $m_1 = m$, $m_2 = 2m$, $r_{1/O} = r$, $r_{2/O} = 3r$.

$$\begin{aligned} I_{zz}^O &= m r^2 + 2m(3r)^2 \\ &= 19m r^2 \end{aligned}$$

$$I_{zz}^O = 19m r^2$$

2. For the equivalent simple pendulum of mass $3m$, let the length of the massless rod (*i.e.*, the distance of the mass from O) be r_{gyr} .

$$(I_{zz}^O)_{\text{simple}} = (3m) \cdot r_{gyr}^2$$

Now we need $(I_{zz}^O)_{\text{simple}} = I_{zz}^O$ (from part (a))

$$\begin{aligned} \Rightarrow 3m r_{gyr}^2 &= 19m r^2 \\ \Rightarrow r_{gyr} &= \sqrt{\frac{19}{3}} r \\ &= 2.52r \end{aligned}$$

Thus the radius of gyration r_{gyr} of the given pendulum is $r_{gyr} = 2.52r$.

$$r_{gyr} = 2.52r$$

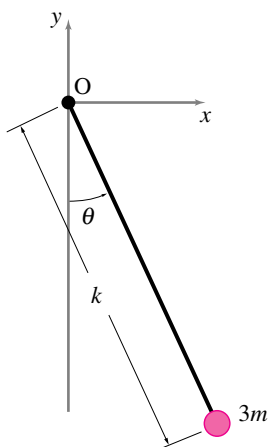

Figure 13.56:

Filename:fig4-5-1a

SAMPLE 13.16 A uniform rigid rod AB of mass $M = 2 \text{ kg}$ and length $3\ell = 1.5 \text{ m}$ swings about the z -axis passing through the pivot point O.

1. Find the moment of inertia I_{zz}^O of the bar using the fundamental definition $I_{zz}^O = \int_m r_{jO}^2 dm$.
2. Find I_{zz}^O using the parallel axis theorem given that $I_{zz}^{\text{cm}} = \frac{1}{12}m\ell^2$ where $m = \text{total mass}$, and $\ell = \text{total length of the rod}$. (You can find I_{zz}^{cm} for many commonly encountered objects in the table on the inside backcover of the text).

Solution

1. Since we need to carry out the integral, $I_{zz}^O = \int_m r_{jO}^2 dm$, to find I_{zz}^O , let us consider an infinitesimal length segment $d\ell'$ of the bar at distance ℓ' from the pivot point O. (see Figure 13.58). Let the mass of the infinitesimal segment be dm .

Now the mass of the segment may be written as

$$\begin{aligned} dm &= (\text{mass per unit length of the bar}) \cdot (\text{length of the segment}) \\ &= \frac{M}{3\ell} d\ell' \quad \left(\text{Note: } \frac{\text{mass}}{\text{unit length}} = \frac{\text{total mass}}{\text{total length}} \right). \end{aligned}$$

We also note that the distance of the segment from point O, $r_{jO} = \ell'$. Substituting the values found above for r_{jO} and dm in the formula we get

$$\begin{aligned} I_{zz}^O &= \int_{-\ell}^{2\ell} \underbrace{(\ell')^2}_{r_{jO}^2} \underbrace{\frac{M}{3\ell} d\ell'}_{dm} \\ &= \frac{M}{3\ell} \int_{-\ell}^{2\ell} (\ell')^2 d\ell' = \frac{M}{3\ell} \left[\frac{\ell'^3}{3} \right]_{-\ell}^{2\ell} \\ &= \frac{M}{3\ell} \left[\frac{8\ell^3}{3} - \left(-\frac{\ell^3}{3} \right) \right] = M\ell^2 \\ &= 2 \text{ kg} \cdot (0.5 \text{ m})^2 = 0.5 \text{ kg} \cdot \text{m}^2. \end{aligned}$$

$$I_{zz}^O = 0.5 \text{ kg} \cdot \text{m}^2$$

2. The parallel axis theorem states that

$$I_{zz}^O = I_{zz}^{\text{cm}} + Mr_{O/\text{cm}}^2.$$

Since the rod is uniform, its center-of-mass is at its geometric center, *i.e.*, at distance $\frac{3\ell}{2}$ from either end. From the Fig 13.59 we can see that

$$r_{O/\text{cm}} = AG - AO = \frac{3\ell}{2} - \ell = \frac{\ell}{2}$$

$$\begin{aligned} \text{Therefore, } I_{zz}^O &= \underbrace{\frac{1}{12}M(3\ell)^2}_{I_{zz}^{\text{cm}}} + M\left(\frac{\ell}{2}\right)^2 \\ &= \frac{9}{12}M\ell^2 + M\frac{\ell^2}{4} = M\ell^2 \\ &= 0.5 \text{ kg} \cdot \text{m}^2 \quad (\text{same as in (a), of course}) \end{aligned}$$

$$I_{zz}^O = 0.5 \text{ kg} \cdot \text{m}^2$$

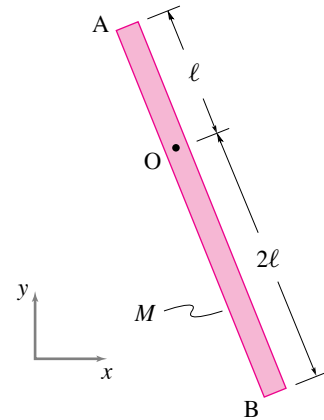

Figure 13.57:

Filename:fig4-5-2

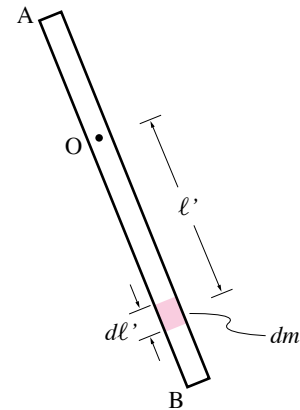

Figure 13.58:

Filename:fig4-5-2a

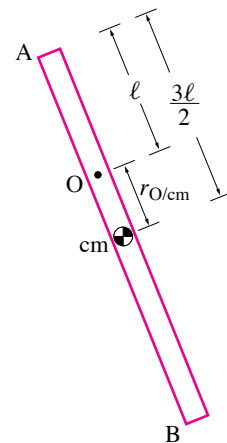

Figure 13.59:

Filename:fig4-5-2b

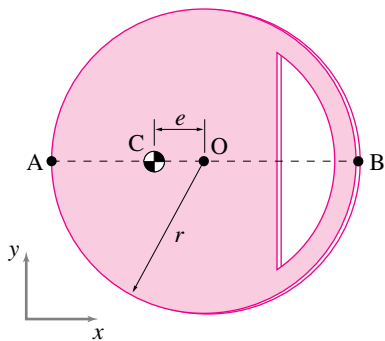

Figure 13.60:

Filename:fig4-5-3

SAMPLE 13.17 A uniform rigid wheel of radius $r = 1$ ft is made eccentric by cutting out a portion of the wheel. The center-of-mass of the eccentric wheel is at C, a distance $e = \frac{r}{3}$ from the geometric center O. The mass of the wheel (after deducting the cut-out) is 3.2 lbm. The moment of inertia of the wheel about point O, I_{zz}^O , is 1.8 lbm·ft². We are interested in the moment of inertia I_{zz} of the wheel about points A and B on the perimeter.

- Without any calculations, guess which point, A or B, gives a higher moment of inertia. Why?
- Calculate I_{zz}^C , I_{zz}^A and I_{zz}^B and compare with the guess in (a).

Solution

- The moment of inertia I_{zz}^B should be higher. Moment of inertia I_{zz} measures the geometric distribution of mass about the z -axis. But the distance of the mass from the axis counts more than the mass itself ($I_{zz}^O = \int_m r_{jO}^2 dm$). The distance r_{jO} of the mass appears as a quadratic term in I_{zz}^O . The total mass is the same whether we take the moment of inertia about point A or about point B. However, the distribution of mass is not the same about the two points. Due to the cut-out being closer to point B there are more “ dm ’s” at greater distances from point B than from point A. So, we guess that

$$I_{zz}^B > I_{zz}^A$$

- If we know the moment of inertia I_{zz}^C (about the center-of-mass) of the wheel, we can use the parallel axis theorem to find I_{zz}^A and I_{zz}^B . In the problem, we are given I_{zz}^O . But,

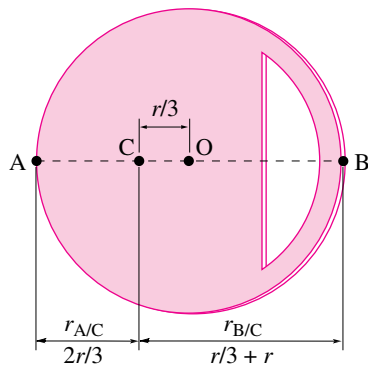

Figure 13.61:

Filename:fig4-5-3a

$$\begin{aligned} I_{zz}^O &= I_{zz}^C + Mr_{O/C}^2 \quad (\text{parallel axis theorem}) \\ \Rightarrow I_{zz}^C &= I_{zz}^O - Mr_{O/C}^2 \\ &= 1.8 \text{ lbm} \cdot \text{ft}^2 - 3.2 \text{ lbm} \underbrace{\left(\frac{1 \text{ ft}}{3}\right)^2}_{r_{O/C} = e = \frac{r}{3}} \\ &= 1.44 \text{ lbm} \cdot \text{ft}^2 \end{aligned}$$

$$\begin{aligned} \text{Now, } I_{zz}^A &= I_{zz}^C + Mr_{A/C}^2 = I_{zz}^C + M \left(\frac{2r}{3}\right)^2 \\ &= 1.44 \text{ lbm} \cdot \text{ft}^2 + 3.2 \text{ lbm} \left(\frac{2 \text{ ft}}{3}\right)^2 \\ &= 2.86 \text{ lbm} \cdot \text{ft}^2 \end{aligned}$$

$$\begin{aligned} \text{and } I_{zz}^B &= I_{zz}^C + Mr_{B/C}^2 = I_{zz}^C + M \left(r + \frac{r}{3}\right)^2 \\ &= 1.44 \text{ lbm} \cdot \text{ft}^2 + 3.2 \text{ lbm} \left(1 \text{ ft} + \frac{1 \text{ ft}}{3}\right)^2 \\ &= 7.13 \text{ lbm} \cdot \text{ft}^2 \end{aligned}$$

$$I_{zz}^C = 1.44 \text{ lbm} \cdot \text{ft}^2, \quad I_{zz}^A = 2.86 \text{ lbm} \cdot \text{ft}^2, \quad I_{zz}^B = 7.13 \text{ lbm} \cdot \text{ft}^2$$

Clearly, $I_{zz}^B > I_{zz}^A$, as guessed in (a).

SAMPLE 13.18 A sphere or a point? A uniform solid sphere of mass m and radius r is attached to a massless rigid rod of length ℓ . The sphere swings in the xy plane. Find the error in calculating I_{zz}^O as a function of r/ℓ if the sphere is treated as a point mass concentrated at the center-of-mass of the sphere.

Solution The exact moment of inertia of the sphere about point O can be calculated using parallel axis theorem:

$$\begin{aligned} I_{zz}^O &= I_{zz}^{cm} + m\ell^2 \\ &= \frac{2}{5}mr^2 + m\ell^2. \quad (\text{See Table IV on inside cover}) \end{aligned}$$

If we treat the sphere as a point mass, the moment of inertia I_{zz}^O is

$$\tilde{I}_{zz}^O = m\ell^2.$$

Therefore, the relative error in I_{zz}^O is

$$\begin{aligned} \text{error} &= \frac{I_{zz}^O - \tilde{I}_{zz}^O}{I_{zz}^O} \\ &= \frac{\frac{2}{5}mr^2 + m\ell^2 - m\ell^2}{\frac{2}{5}mr^2 + m\ell^2} \\ &= \frac{\frac{2}{5}\frac{r^2}{\ell^2}}{\frac{2}{5}\frac{r^2}{\ell^2} + 1} \end{aligned}$$

From the above expression we see that for $r \ll \ell$ the error is very small. From the graph of error in Fig. 13.63 we see that even for $r = \ell/5$, the error in I_{zz}^O due to approximating the sphere as a point mass is less than 2%.

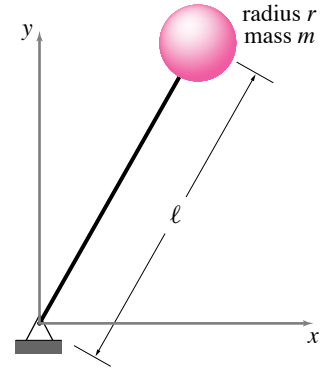

Figure 13.63:

Filename:fig4-5-4

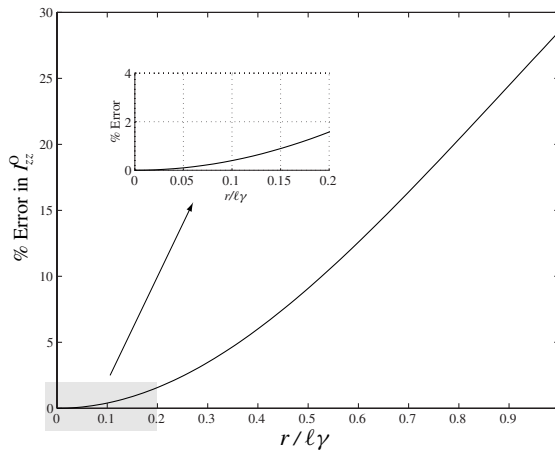

Figure 13.62: Relative error in I_{zz}^O of the sphere as a function of r/ℓ .

Filename:fig4-5-4a

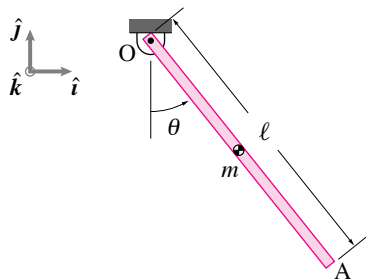

Figure 13.64: A uniform rod swings in the plane about its pinned end O.

Filename:fig5-4-1a-izz

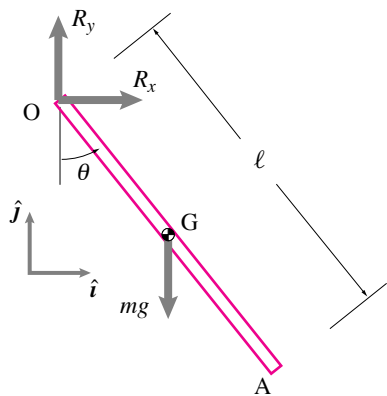

Figure 13.65: The free-body diagram of the rod.

Filename:fig5-4-1b-izz

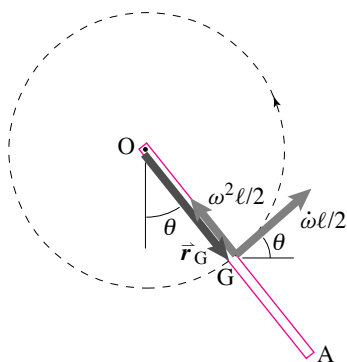

Figure 13.66: Radial and tangential components of \vec{a}_G . Since the radial component is parallel to \vec{r}_G , $\vec{r}_G \times \vec{a}_G = \frac{\ell^2}{4} \dot{\omega} \hat{k}$.

Filename:fig5-4-1c

SAMPLE 13.19 The swinging stick again. A uniform bar of mass m and length ℓ is pinned at one of its ends O. The bar is displaced from its vertical position by an angle θ and released (Fig. 13.64). Find the equation of motion of the stick.

Solution We repeat the problem solved in Sample 13.22 here with just one different step of finding the rate of change of angular momentum with the help of moment of inertia formula. As usual, we first draw a free-body diagram of the bar (Fig. 13.65). We assume, $\vec{\omega} = \omega \hat{k} \equiv \dot{\theta} \hat{k}$, and $\vec{\dot{\omega}} = \dot{\omega} \hat{k} \equiv \ddot{\theta} \hat{k}$. We can write angular momentum balance about point O as

$$\sum \vec{M}_O = \dot{\vec{H}}_O.$$

Let us now calculate both sides of this equation:

$$\begin{aligned} \sum \vec{M}_O &= \vec{r}_{G/O} \times mg(-\hat{j}) \\ &= \frac{\ell}{2} (\sin \theta \hat{i} - \cos \theta \hat{j}) \times mg(-\hat{j}) \\ &= -\frac{\ell}{2} mg \sin \theta \hat{k}. \end{aligned} \quad (13.41)$$

$$\begin{aligned} \dot{\vec{H}}_O &= I_{zz/G} \dot{\vec{\omega}} + \vec{r}_G \times m \vec{a}_G \\ &= \frac{m\ell^2}{12} \dot{\omega} \hat{k} + \vec{r}_G \times m \underbrace{\vec{a}_G}_{\omega \hat{k} \times \vec{r}_G - \omega^2 \vec{r}_G} \\ &= \frac{m\ell^2}{12} \dot{\omega} \hat{k} + \frac{m\ell^2}{4} \dot{\omega} \hat{k} = \frac{m\ell^2}{3} \dot{\omega} \hat{k} \end{aligned} \quad (13.42)$$

where the last step, $\vec{r}_G \times m \vec{a}_G = \frac{m\ell^2}{4} \dot{\omega} \hat{k}$, should be clear from Fig. 13.66. Equating (13.41) and (13.50) we get

$$\begin{aligned} -\frac{\ell}{2} \eta g \sin \theta &= \eta \frac{\ell^2}{3} \dot{\omega} \\ \text{or } \dot{\omega} + \frac{3g}{2\ell} \sin \theta &= 0 \\ \text{or } \ddot{\theta} + \frac{3g}{2\ell} \sin \theta &= 0. \end{aligned} \quad (13.43)$$

$$\boxed{\ddot{\theta} + \frac{3g}{2\ell} \sin \theta = 0}$$

13.5 Polar moment of inertia

We know how to find the velocity and acceleration of every bit of mass on a 2-D rigid body as it spins about a fixed axis. So, as explained in the previous section, it is just a matter of doing integrals or sums to calculate the various motion quantities (momenta, energy) of interest. As the body moves and rotates the region of integration and the values of the integrands change. So, in principle, in order to analyze a rigid body one has to evaluate a different integral or sum at every different configuration. But there is a shortcut. A big sum (over all atoms, say), or a difficult integral is reduced to a simple multiplication.

The moment of inertia matrix $[\mathbf{I}]$ ^① is defined to simplify the expressions for the angular momentum, the rate of change of angular momentum, and the energy of a rigid body. For study of the analysis of flat objects in planar motion only one component of the matrix $[\mathbf{I}]$ is relevant, it is I_{zz} , called just I or J in elementary physics courses. Here are the results. A flat object spinning with $\vec{\omega} = \omega \hat{\mathbf{k}}$ in the xy plane has a mass distribution which gives, by means of a calculation which we will discuss shortly, a moment of inertia I_{zz}^{cm} or just ‘ I ’ so that:

$$\vec{H}_{cm} = I\omega \hat{\mathbf{k}} \quad (13.44)$$

$$\dot{\vec{H}}_{cm} = I\dot{\omega} \hat{\mathbf{k}} \quad (13.45)$$

$$E_{K/cm} = \frac{1}{2}\omega^2 I. \quad (13.46)$$

The moments of inertia in 2-D : $[I^{cm}]$ and $[I^O]$.

We start by looking at the scalar I which is just the zz or 33 component of the matrix $[\mathbf{I}]$ that we will study later. The definition of I^{cm} is

$$I^{cm} \equiv \int \underbrace{x^2 + y^2}_{r^2} dm$$

$$= \int \int r^2 \underbrace{\left(\frac{m_{tot}}{A}\right)}_{\substack{dm \\ \text{The mass per unit area.}}} dA \quad \text{for a uniform planar object}$$

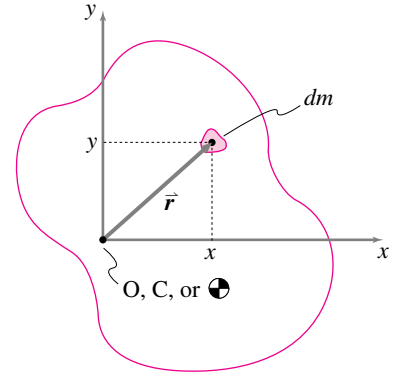

Figure 13.67: A bit of mass dm on a general planar body.

Filename:figure4-4-Defoff

① In fact the moment of inertia for a given object depends on what reference point is used. Most commonly when people say ‘the’ moment of inertia they mean to use the center-of-mass as the reference point. For clarity this moment of inertia matrix is often notated as $[\mathbf{I}^{cm}]$ in this book. If a different reference point, say point O is used, the matrix is notated as $[\mathbf{I}^O]$.

where x and y are the distances of the mass in the x and y direction measured from an origin, and $r = r_{/cm}$ is the direct distance from that origin. If that origin is at the center-of-mass then we are calculating I^{cm} , if the origin is at a point labeled C or O then we are calculating I^C or I^O .

The term I_{zz} is sometimes called the *polar moment of inertia*, or *polar mass moment of inertia* to distinguish it from the I_{xx} and I_{yy} terms which have little utility in planar dynamics (but are all important when calculating the stiffness of beams!).

What, physically, is the moment of inertia? It is a measure of the extent to which mass is far from the given reference point. Every bit of mass contributes to I in proportion to the square of its distance from the reference point. Note from, say, *eqn. (13.71)* on page 79 that I is just the quantity we need to do mechanics problems.

Radius of gyration

Another measure of the extent to which mass is spread from the reference point, besides the moment of inertia, is the *radius of gyration*, r_{gyr} . The radius of gyration is sometimes called k but we save k for stiffness. The radius of gyration is defined as:

$$r_{gyr} \equiv \sqrt{I/m} \Rightarrow r_{gyr}^2 m = I.$$

That is, the radius of gyration of an object is the radius of an equivalent ring of mass that has the same I and the same mass as the given object.

Other reference points

For the most part it is I^{cm} which is of primary interest. Other reference points are useful

1. if the rigid body is hinged at a fixed point O then a slight short cut in calculation of angular momentum and energy terms can be had; and
2. if one wants to calculate the moment of inertia of a composite body about its center-of-mass it is useful to first find the moment of inertia of each of its parts about that point. But the center-of-mass of the composite is usually not the center-of-mass of any of the separate parts.

The box 13.7 on page 54 shows the calculation of I for a number of simple 2 dimensional objects.

The parallel axis theorem for planar objects

The planar parallel axis theorem is the equation

$$I_{zz}^C = I_{zz}^{cm} + m_{\text{tot}} \underbrace{r_{cm/C}^2}_{d^2}.$$

In this equation $d = r_{cm/C}$ is the distance from the center-of-mass to a line parallel to the z -axis which passes through point C . See box 13.6 on page 50 for a derivation of the parallel axis theorem for planar objects.

Note that $I_{zz}^C \geq I_{zz}^{cm}$, always.

One can calculate the moment of inertia of a composite body about its center of mass, in terms of the masses and moments of inertia of the separate parts. Say the position of the center of mass of m_i is (x_i, y_i) relative to a fixed origin, and the moment of inertia of that part about its center of mass is I_i . We can then find the moment of inertia of the composite I_{tot} about its center-of-mass (x_{cm}, y_{cm}) by the following sequence of calculations:

$$\begin{aligned} (1) \quad m_{tot} &= \sum m_i \\ (2) \quad x_{cm} &= [\sum x_i m_i] / m_{tot} \\ y_{cm} &= [\sum y_i m_i] / m_{tot} \\ (3) \quad d_i^2 &= (x_i - x_{cm})^2 + (y_i - y_{cm})^2 \\ (4) \quad I_{tot} &= \sum [I_i^{cm} + m_i d_i^2]. \end{aligned}$$

Of course if you are mathematically inclined you can reduce this recipe to one grand formula with lots of summation signs. But you would end up doing the calculation in about this order in any case. As presented here this sequence of steps lends itself naturally to computer calculation with a spread sheet or any program that deals easily with arrays of numbers.

The tidy recipe just presented is actually more commonly used, with slight modification, in strength of materials than in dynamics. The need for finding area moments of inertia of strange beam cross sections arises more frequently than the need to find polar mass moment of inertia of a strange cutout shape.

The perpendicular axis theorem for planar rigid bodies

The perpendicular axis theorem for planar objects is the equation

$$I_{zz} = I_{xx} + I_{yy}$$

which is derived in box 13.6 on page 50. It gives the ‘polar’ inertia I_{zz} in terms of the inertias I_{xx} and I_{yy} . Unlike the parallel axis theorem, the perpendicular axis theorem does *not* have a three-dimensional counterpart. The theorem is of greatest utility when one wants to study the three-dimensional mechanics of a flat object and thus are in need of its full moment of inertia matrix.

13.6 THEORY

The 2-D parallel axis theorem and the perpendicular axis theorem

Sometimes, one wants to know the moment of inertia relative to the center of mass and, sometimes, relative to some other point O , if the object is held at a hinge joint at O . There is a simple relation between these two moments of inertia known as *the parallel axis theorem*.

2-D parallel axis theorem

For the two-dimensional mechanics of two-dimensional objects, our only concern is I_{zz}^O and I_{zz}^{cm} and *not* the full moment of inertia matrix. In this case, $I_{zz}^O = \int r_{/O}^2 dm$ and $I_{zz}^{cm} = \int r_{/cm}^2 dm$. Now, let's prove the theorem in two dimensions referring to the figure.

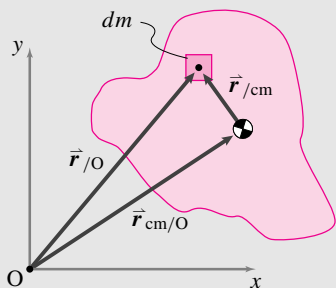

$$\begin{aligned}
 I_{zz}^O &= \int r_{/O}^2 dm \\
 &= \int (x_{/O}^2 + y_{/O}^2) dm \\
 &= \int \left[\underbrace{(x_{cm/O} + x_{/cm})^2}_{x_{/O}} + \underbrace{(y_{cm/O} + y_{/cm})^2}_{y_{/O}} \right] dm \\
 &= \int [x_{cm/O}^2 + 2x_{cm/O}x_{/cm} + x_{/cm}^2 + (y_{cm/O}^2 + 2y_{cm/O}y_{/cm} + y_{/cm}^2)] dm \\
 &= (x_{cm/O}^2 + y_{cm/O}^2) \int dm + 2x_{cm/O} \int x_{/cm} dm + 2y_{cm/O} \int y_{/cm} dm + \int (x_{/cm}^2 + y_{/cm}^2) dm \\
 &= r_{cm/O}^2 m + \underbrace{\int (x_{/cm}^2 + y_{/cm}^2) dm}_{I_{zz}^{cm}} \\
 &= I_{zz}^{cm} + \underbrace{r_{cm/O}^2 m}_{d^2}
 \end{aligned}$$

The cancellation $\int y_{/cm} dm = \int x_{/cm} dm = 0$ comes from the definition of center of mass.

Sometimes, people write the parallel axis theorem more simply as

$$I^O = I^{cm} + md^2 \quad \text{or} \quad J_O = J_{cm} + md^2$$

using the symbol J to mean I_{zz} . One thing to note about the parallel axis theorem is that the moment of inertia about any point O is always *greater* than the moment of inertia about the center of mass. For a given object, the minimum moment of inertia is about the center-of-mass.

Why the name *parallel axis theorem*? We use the name because the two I 's calculated are the moments of inertia about two parallel axes (both in the z direction) through the two points cm and O .

One way to think about the theorem is the following. The moment of inertia of an object about a point O not at the center-of-mass is the same as that of the object about the cm plus that of a point mass located at the center-of-mass. If the distance from O to the cm is larger than the outer radius of the object, then the d^2m term is larger than I_{zz}^{cm} . The distance of equality of the two terms is the radius of gyration, r_{gyr} .

Perpendicular axis theorem (applies to planar objects only)

For planar objects,

$$\begin{aligned}
 I_{zz}^O &= \int |\vec{r}|^2 dm \\
 &= \int (x_{/O}^2 + y_{/O}^2) dm \\
 &= \int x_{/O}^2 dm + \int y_{/O}^2 dm \\
 &= I_{yy}^O + I_{xx}^O
 \end{aligned}$$

Similarly,

$$I_{zz}^{cm} = I_{xx}^{cm} + I_{yy}^{cm}$$

that is, the moment of inertia about the z -axis is the sum of the inertias about the two perpendicular axes x and y . Note that the objects must be planar ($z = 0$ everywhere) or the theorem would not be true. For example, $I_{xx}^O = \int (y_{/O}^2 + z_{/O}^2) dm \neq \int y_{/O}^2 dm$ for a three-dimensional object.

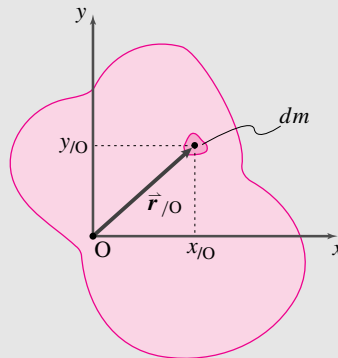

SAMPLE 13.20 A rod going in circles at constant rate. A uniform rod of mass m and length ℓ is connected to a motor at end O. A ball of mass m is attached to the rod at end B. The motor turns the rod in counterclockwise direction at a constant angular speed ω . There is gravity pointing in the $-\hat{j}$ direction. Find the torque applied by the motor (i) at the instant shown and (ii) when $\theta = 0^\circ, 90^\circ, 180^\circ$. How does the torque change if the angular speed is doubled?

Solution The FBD of the rod and ball system is shown in Fig. 13.69(a). Since the system is undergoing circular motion at a constant speed, the acceleration of the ball as well as every point on the rod is just radial (pointing towards the center of rotation O) and is given by $\vec{a} = -\omega^2 r \hat{\lambda}$ where r is the radial distance from the center O to the point of interest and $\hat{\lambda}$ is a unit vector along OB pointing away from O (Fig. 13.69(b)).

Angular Momentum Balance about point O gives

$$\begin{aligned} \sum \vec{M}_O &= \dot{\vec{H}}_O \\ \sum \vec{M}_O &= \vec{r}_{G/O} \times (-mg\hat{j}) + \vec{r}_{B/O} \times (-mg\hat{j}) + M\hat{k} \\ &= -\frac{\ell}{2} \cos \theta mg \hat{k} - \ell \cos \theta mg \hat{k} + M\hat{k} \\ &= \left(M - \frac{3\ell}{2} mg \cos \theta\right) \hat{k} \end{aligned} \quad (13.47)$$

$$\begin{aligned} \dot{\vec{H}}_O &= \underbrace{\dot{\vec{H}}_O}_{\text{ball}} + \underbrace{\dot{\vec{H}}_O}_{\text{rod}} \\ &= \vec{r}_{B/O} \times m \vec{a}_B + \int_m \vec{r}_{dm/O} \times \vec{a}_{dm} dm \\ &= \ell \hat{\lambda} \times (-m\omega^2 \ell \hat{\lambda}) + \int_m \underbrace{\vec{r}_{dm/O}}_{s \hat{\lambda}} \times \underbrace{\vec{a}_{dm}}_{(-\omega^2 s \hat{\lambda})} dm \\ &= \vec{0} \quad (\text{since } \hat{\lambda} \times \hat{\lambda} = \vec{0}) \end{aligned} \quad (13.48)$$

(i) Equating (13.47) and (13.48) we get

$$M = \frac{3}{2} mg \ell \cos \theta.$$

$$M = \frac{3}{2} mg \ell \cos \theta$$

(ii) Substituting the given values of θ in the above expression we get

$$M(\theta = 0^\circ) = \frac{3}{2} mg \ell, \quad M(\theta = 90^\circ) = 0, \quad M(\theta = 180^\circ) = -\frac{3}{2} mg \ell$$

$$M(0^\circ) = \frac{3}{2} mg \ell, \quad M(90^\circ) = 0, \quad M(180^\circ) = -\frac{3}{2} mg \ell$$

The values obtained above make sense (at least qualitatively). To make the rod and the ball go up from the 0° position, the motor has to apply some torque in the counterclockwise direction. In the 90° position no torque is required for the *dynamic balance*. In 180° position the system is accelerating downwards under gravity; therefore, the motor has to apply a clockwise torque to make the system maintain a uniform speed.

It is clear from the expression of the torque that it does not depend on the value of the angular speed ω ! Therefore, the torque will not change if the speed

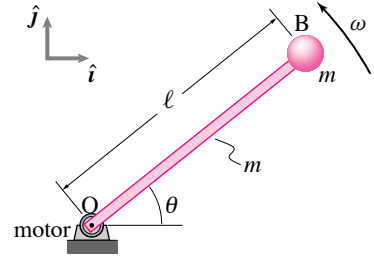
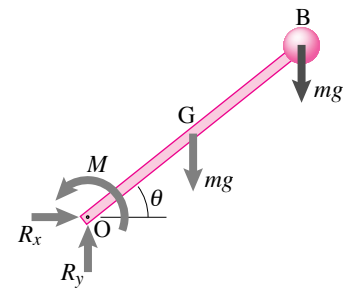
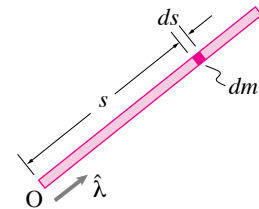

Figure 13.68: A rod goes in circles at a constant rate.

Filename:fig4-5-5



(a) FBD of rod+ball system



(b) Calculation of $\dot{\vec{H}}_O$ of the rod

Figure 13.69: A rod goes in circles at a constant rate.

Filename:fig4-5-5a

is doubled. In fact, as long as the speed remains constant at any value, the only torque required to maintain the motion is the torque to counteract the moments at O due to gravity.

SAMPLE 13.21 A compound gear train. When the gear of an input shaft, often called the *driver* or the *pinion*, is directly meshed in with the gear of an output shaft, the motion of the output shaft is opposite to that of the input shaft. To get the output motion in the same direction as that of the input motion, an *idler* gear is used. If the idler shaft has more than one gear in mesh, then the gear train is called a *compound gear train*.

In the gear train shown in Fig. 13.70, the input shaft is rotating at 2000 rpm and the input torque is 200 N·m. The efficiency (defined as the ratio of output power to input power) of the train is 0.96 and the various radii of the gears are: $R_A = 5$ cm, $R_B = 8$ cm, $R_C = 4$ cm, and $R_D = 10$ cm. Find

1. the input power P_{in} and the output power P_{out} ,
2. the output speed ω_{out} , and
3. the output torque.

Solution

1. The power:

$$\begin{aligned} P_{in} &= M_{in} \omega_{in} = 200 \text{ N}\cdot\text{m} \cdot 2000 \text{ rpm} \\ &= 400000 \text{ N}\cdot\text{m} \cdot \frac{\text{r}\ddot{\text{e}}\text{v}}{\text{m}\ddot{\text{i}}\text{n}} \cdot \frac{2\pi}{1 \text{ r}\ddot{\text{e}}\text{v}} \cdot \frac{1 \text{ m}\ddot{\text{i}}\text{n}}{60 \text{ s}} \\ &= 41887.9 \text{ N m/s} \approx 42 \text{ kW} \\ \Rightarrow p_{out} &= \text{efficiency} \cdot P_{in} = 0.96 \cdot 42 \text{ kW} \approx 40 \text{ kW} \end{aligned}$$

$$P_{in} = 42 \text{ kW}, \quad p_{out} = 40 \text{ kW}$$

2. The angular speed of meshing gears can be easily calculated by realizing that the linear speed of the point of contact has to be the same irrespective of which gear's speed and geometry is used to calculate it. Thus,

$$\begin{aligned} v_P &= \omega_{in} R_A = \omega_B R_B \\ \Rightarrow \omega_B &= \omega_{in} \cdot \frac{R_A}{R_B} \\ \text{and } v_R &= \omega_C R_C = \omega_{out} R_D \\ \Rightarrow \omega_{out} &= \omega_C \cdot \frac{R_C}{R_D} \\ \text{But } \omega_C &= \omega_B \\ \Rightarrow \omega_{out} &= \omega_{in} \cdot \frac{R_A}{R_B} \cdot \frac{R_C}{R_D} \\ &= 2000 \text{ rpm} \cdot \frac{5}{8} \cdot \frac{4}{10} = 500 \text{ rpm}. \end{aligned}$$

$$\omega_{out} = 500 \text{ rpm}$$

3. The output torque,

$$\begin{aligned} M_{out} &= \frac{P_{out}}{\omega_{out}} = \frac{40 \text{ kW}}{500 \text{ rpm}} \\ &= \frac{40}{500} \cdot 1000 \frac{\text{N}\cdot\text{m}}{\ddot{\text{s}}} \cdot \frac{\text{m}\ddot{\text{i}}\text{n}}{\text{r}\ddot{\text{e}}\text{v}} \cdot \frac{1 \text{ r}\ddot{\text{e}}\text{v}}{2\pi} \cdot \frac{60 \ddot{\text{s}}}{1 \text{ m}\ddot{\text{i}}\text{n}} \\ &= 764 \text{ N}\cdot\text{m}. \end{aligned}$$

$$M_{out} = 764 \text{ N}\cdot\text{m}$$

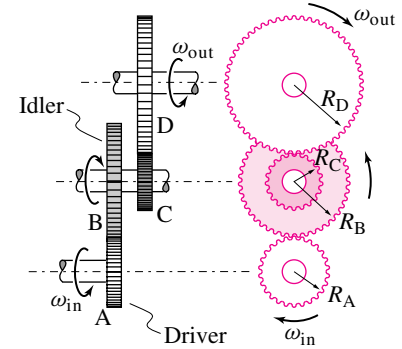

Figure 13.70: A compound gear train.

Filename:fig4-5-7

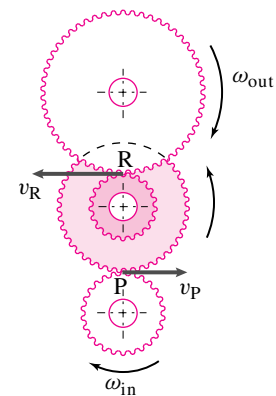

Figure 13.71:

Filename:fig4-5-7a

13.7 Some examples of 2-D Moment of Inertia

Here, we illustrate some simple moment of inertia calculations for two-dimensional objects. The needed formulas are summarized, in part, by the lower right corner components (that is, the elements in the third column and third row (3,3)) of the matrices in the table on the inside back cover.

One point mass

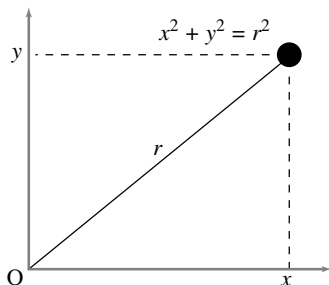

If we assume that all mass is concentrated at one or more points, then the integral

$$I_{zz}^o = \int r_{i/o}^2 dm$$

reduces to the sum

$$I_{zz}^o = \sum r_{i/o}^2 m_i$$

which reduces to one term if there is only one mass,

$$I_{zz}^o = r^2 m = (x^2 + y^2)m.$$

So, if $x = 3$ in, $y = 4$ in, and $m = 0.1$ lbm, then $I_{zz}^o = 2.5$ lbm in². Note that, in this case, $I_{zz}^{cm} = 0$ since the radius from the center-of-mass to the center-of-mass is zero.

Two point masses

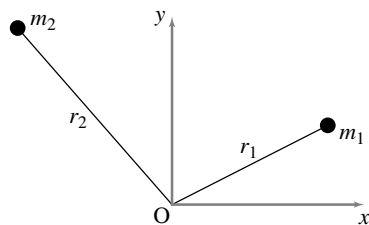

In this case, the sum that defines I_{zz}^o reduces to two terms, so

$$I_{zz}^o = \sum r_{i/o}^2 m_i = m_1 r_1^2 + m_2 r_2^2.$$

Note that, if $r_1 = r_2 = r$, then $I_{zz}^o = m_{tot} r^2$.

A thin uniform rod

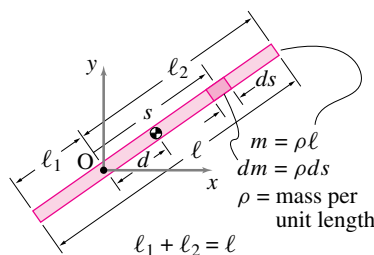

Consider a thin rod with uniform mass density, ρ , per unit length, and length ℓ . We calculate I_{zz}^o as

$$\begin{aligned} I_{zz}^o &= \int r^2 \overbrace{dm}^{\rho ds} \\ &= \int_{-\ell_1}^{\ell_2} s^2 \rho ds \quad (s = r) \\ &= \frac{1}{3} \rho s^3 \Big|_{-\ell_1}^{\ell_2} \quad (\text{since } \rho \equiv \text{const.}) \\ &= \frac{1}{3} \rho (\ell_1^3 + \ell_2^3). \end{aligned}$$

If either $\ell_1 = 0$ or $\ell_2 = 0$, then this expression reduces to $I_{zz}^o = \frac{1}{3} m \ell^2$. If $\ell_1 = \ell_2$, then O is at the center-of-mass and

$$I_{zz}^o = I_{zz}^{cm} = \frac{1}{3} \rho \left(\left(\frac{\ell}{2} \right)^3 + \left(\frac{\ell}{2} \right)^3 \right) = \frac{m \ell^2}{12}.$$

We can illustrate one last point. With a little bit of algebraic histrionics of the type that only hindsight can inspire, you can verify that the expression for I_{zz}^o can be arranged as follows:

$$\begin{aligned} I_{zz}^o &= \frac{1}{3} \rho (\ell_1^3 + \ell_2^3) \\ &= \underbrace{\rho (\ell_1 + \ell_2)}_m \left(\frac{\ell_2 - \ell_1}{2} \right)^2 + \underbrace{\rho \frac{(\ell_1 + \ell_2)^3}{12}}_{m \ell^2 / 12} \\ &= m d^2 + m \frac{\ell^2}{12} \\ &= m d^2 + I_{zz}^{cm} \end{aligned}$$

That is, the moment of inertia about point O is greater than that about the center of mass by an amount equal to the mass times the distance from the center-of-mass to point O squared. This derivation of the *parallel axis theorem* is for one special case, that of a uniform thin rod.

A uniform hoop

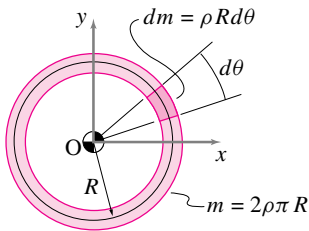

For a hoop of uniform mass density, ρ , per unit length, we might consider all of the points to have the same radius R . So,

$$I_{zz}^o = \int r^2 dm = \int R^2 dm = R^2 \int dm = R^2 m.$$

Or, a little more tediously,

$$\begin{aligned} I_{zz}^o &= \int r^2 dm \\ &= \int_0^{2\pi} R^2 \rho R d\theta \\ &= \rho R^3 \int_0^{2\pi} d\theta \\ &= 2\pi \rho R^3 = \underbrace{(2\pi \rho R)}_m R^2 = m R^2. \end{aligned}$$

This I_{zz}^o is the same as for a single point mass m at a distance R from the origin O . It is also the same as for two point masses if they both are a distance R from the origin. For the hoop, however, O is at the center-of-mass so $I_{zz}^o = I_{zz}^{cm}$ which is not the case for a single point mass.

A uniform disk

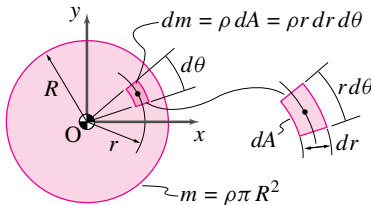

Assume the disk has uniform mass density, ρ , per unit area. For a uniform disk centered at the origin, the center-of-mass is at the origin so

$$\begin{aligned} I_{zz}^o = I_{zz}^{cm} &= \int r^2 dm \\ &= \int_0^R \int_0^{2\pi} r^2 \rho r d\theta dr \\ &= \int_0^R 2\pi \rho r^3 dr \\ &= 2\pi \rho \frac{r^4}{4} \Big|_0^R = \pi \rho \frac{R^4}{2} = (\pi \rho R^2) \frac{R^2}{2} \\ &= m \frac{R^2}{2}. \end{aligned}$$

For example, a 1 kg plate of 1 m radius has the same moment of inertia as a 1 kg hoop with a 70.7 cm radius.

Uniform rectangular plate

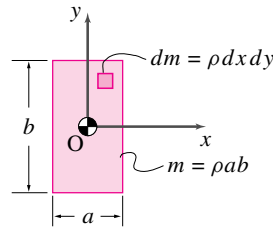

For the special case that the center of the plate is at point O , the center-of-mass of mass is also at O and $I_{zz}^o = I_{zz}^{cm}$.

$$\begin{aligned} I_{zz}^o = I_{zz}^{cm} &= \int r^2 dm \\ &= \int_{-\frac{b}{2}}^{\frac{b}{2}} \int_{-\frac{a}{2}}^{\frac{a}{2}} (x^2 + y^2) \overbrace{\rho dx dy}^{dm} \\ &= \int_{-\frac{b}{2}}^{\frac{b}{2}} \rho \left(\frac{x^3}{3} + xy^2 \right) \Big|_{x=-\frac{a}{2}}^{x=\frac{a}{2}} dy \\ &= \rho \left(\frac{x^3 y}{3} + \frac{xy^3}{3} \right) \Big|_{x=-\frac{a}{2}}^{x=\frac{a}{2}} \Big|_{y=-\frac{b}{2}}^{y=\frac{b}{2}} \\ &= \rho \left(\frac{a^3 b}{12} + \frac{ab^3}{12} \right) \\ &= \frac{m}{12} (a^2 + b^2). \end{aligned}$$

Note that $\int r^2 dm = \int x^2 dm + \int y^2 dm$ for all planar objects (the *perpendicular axis theorem*). For a uniform rectangle, $\int y^2 dm = \rho \int y^2 dA$. But the integral $\int y^2 dA$ is just the term often used for I , the area moment of inertia, in strength of materials calculations for the stresses and stiffnesses of beams in bending. You may recall that $\int y^2 dA = \frac{ab^3}{12} = \frac{Ab^2}{12}$ for a rectangle. Similarly, $\int x^2 dA = \frac{Aa^2}{12}$. So, the polar moment of inertia $J = I_{zz}^o = m \frac{1}{12} (a^2 + b^2)$ can be recalled by remembering the area moment of inertia of a rectangle combined with the perpendicular axis theorem.

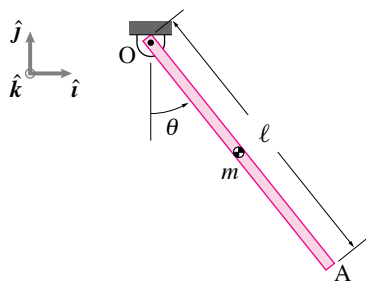

Figure 13.72: A uniform rod swings in the plane about its pinned end O.

Filename:fig5-4-1a

SAMPLE 13.22 The swinging stick. A uniform bar of mass m and length ℓ is pinned at one of its ends O. The bar is displaced from its vertical position by an angle θ and released (Fig. 13.72).

1. Find the equation of motion using momentum balance.
2. Find the reaction at O as a function of $(\theta, \dot{\theta}, g, m, \ell)$.

Solution First we draw a simple sketch of the given problem showing relevant geometry (Fig. 13.72(a)), and then a free-body diagram of the bar (Fig. 13.72(b)).

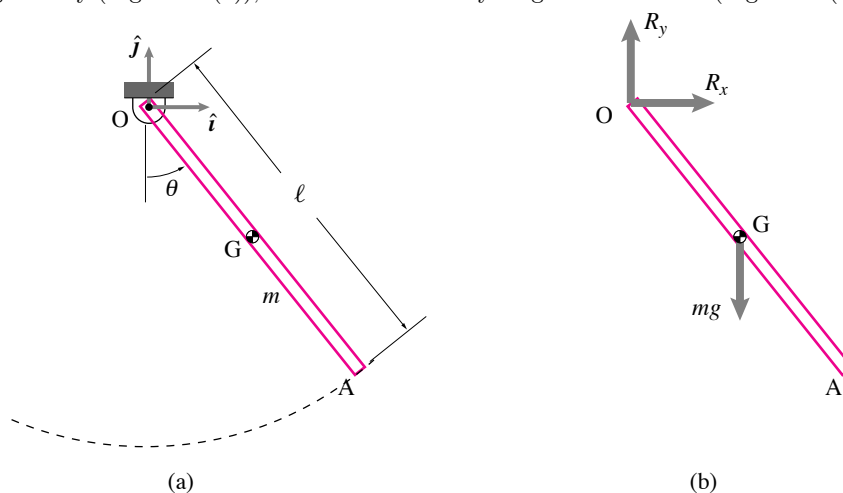

Figure 13.74: (a) A line sketch of the swinging rod and (b) free-body diagram of the rod.

Filename:fig5-4-1b

We should note for future reference that

$$\begin{aligned}\vec{\omega} &= \omega \hat{k} \equiv \dot{\theta} \hat{k} \\ \dot{\vec{\omega}} &= \dot{\omega} \hat{k} \equiv \ddot{\theta} \hat{k}\end{aligned}$$

1. **Equation of motion using momentum balance:** We can write angular momentum balance about point O as

$$\sum \vec{M}_O = \dot{\vec{H}}_O.$$

Let us now calculate both sides of this equation:

$$\begin{aligned}\sum \vec{M}_O &= \vec{r}_{G/O} \times mg(-\hat{j}) \\ &= \frac{\ell}{2} (\sin \theta \hat{i} - \cos \theta \hat{j}) \times mg(-\hat{j}) \\ &= -\frac{\ell}{2} mg \sin \theta \hat{k}.\end{aligned}\tag{13.49}$$

$$\begin{aligned}\dot{\vec{H}}_O &= \dot{\omega} \hat{k} \int_m r^2 dm \\ &= \ddot{\theta} \hat{k} \int_0^\ell s^2 \frac{m}{\ell} ds \quad (dm = m/\ell \cdot ds) \\ &= \frac{m \ddot{\theta}}{\ell} \left[\frac{s^3}{3} \Big|_0^\ell \right] = \frac{m \ell^2}{3} \ddot{\theta} \hat{k}\end{aligned}\tag{13.50}$$

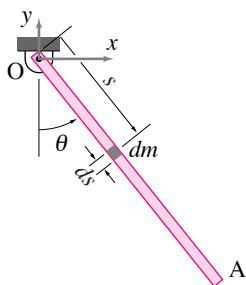

Figure 13.73: Computation of $\dot{\vec{H}}_O$ by integration over the rod.

Filename:fig5-4-1a-new

Equating (13.49) and (13.50) we get

$$\begin{aligned} -\frac{\ell}{2}\dot{\theta}g \sin \theta &= \dot{\theta} \frac{\ell^2}{3}\ddot{\theta} \\ \text{or} \quad \dot{\omega} + \frac{3g}{2\ell} \sin \theta &= 0 \\ \text{or} \quad \ddot{\theta} + \frac{3g}{2\ell} \sin \theta &= 0. \end{aligned} \quad (13.51)$$

$$\boxed{\ddot{\theta} + \frac{3g}{2\ell} \sin \theta = 0}$$

2. **Reaction at O:** Using linear momentum balance

$$\begin{aligned} \sum \vec{F} &= m \vec{a}_G, \\ \text{where} \quad \sum \vec{F} &= R_x \hat{i} + (R_y - mg) \hat{j}, \\ \text{and} \quad \vec{a}_G &= \frac{\ell}{2} \dot{\omega} (\cos \theta \hat{i} + \sin \theta \hat{j}) + \frac{\ell}{2} \omega^2 (-\sin \theta \hat{i} + \cos \theta \hat{j}) \\ &= \frac{\ell}{2} [(\dot{\omega} \cos \theta - \omega^2 \sin \theta) \hat{i} + (\dot{\omega} \sin \theta + \omega^2 \cos \theta) \hat{j}]. \end{aligned}$$

Dotting both sides of $\sum \vec{F} = m \vec{a}_G$ with \hat{i} and \hat{j} and rearranging, we get

$$\begin{aligned} R_x &= m \frac{\ell}{2} (\dot{\omega} \cos \theta - \omega^2 \sin \theta) \\ &\equiv m \frac{\ell}{2} (\ddot{\theta} \cos \theta - \dot{\theta}^2 \sin \theta), \\ R_y &= mg + m \frac{\ell}{2} (\dot{\omega} \sin \theta + \omega^2 \cos \theta) \\ &\equiv mg + m \frac{\ell}{2} (\ddot{\theta} \sin \theta + \dot{\theta}^2 \cos \theta). \end{aligned}$$

Now substituting the expression for $\ddot{\theta}$ from (13.51) in R_x and R_y , we get

$$R_x = -m \sin \theta \left(\frac{3}{4} g \cos \theta + \frac{\ell}{2} \dot{\theta}^2 \right), \quad (13.52)$$

$$R_y = mg \left(1 - \frac{3}{4} \sin^2 \theta \right) + m \frac{\ell}{2} \dot{\theta}^2 \cos \theta. \quad (13.53)$$

$$\boxed{\vec{R} = -m \left(\frac{3}{4} g \cos \theta + \frac{\ell}{2} \dot{\theta}^2 \right) \sin \theta \hat{i} + [mg \left(1 - \frac{3}{4} \sin^2 \theta \right) + m \frac{\ell}{2} \dot{\theta}^2 \cos \theta] \hat{j}}$$

Check: We can check the reaction force in the special case when the rod does not swing but just hangs from point O. The forces on the bar in this case have to satisfy static equilibrium. Therefore, the reaction at O must be equal to mg and directed vertically upwards. Plugging $\theta = 0$ and $\dot{\theta} = 0$ (no motion) in Eqn. (13.52) and (13.53) we get $R_x = 0$ and $R_y = mg$, the values we expect.

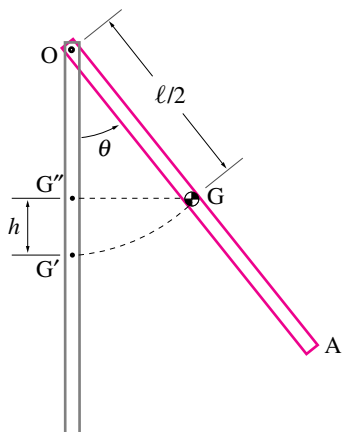

Figure 13.75: Work done by the force of gravity in moving from G' to G $\int \vec{F} \cdot d\vec{r} = -mg\hat{j} \cdot h\hat{j} = -mgh$.

Filename:fig5-4-2a

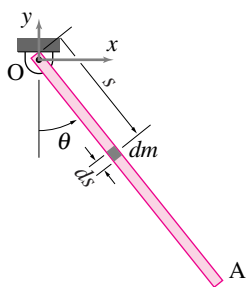

Figure 13.76: The infinitesimal mass dm considered in the calculation of E_K .

Filename:fig5-4-2a-new

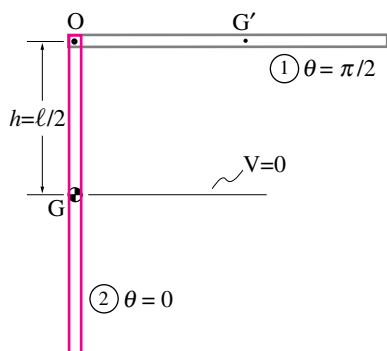

Figure 13.77: The total energy between positions (1) and (2) is constant.

Filename:fig5-4-2b

SAMPLE 13.23 The swinging stick: energy balance. Consider the same swinging stick as in Sample 13.22. The stick is, again, displaced from its vertical position by an angle θ and released (See Fig. 13.72).

1. Find the equation of motion using energy balance.
2. What is $\dot{\theta}$ at $\theta = 0$ if $\theta(t = 0) = \pi/2$?
3. Find the period of small oscillations about $\theta = 0$.

Solution

1. **Equation of motion using energy balance:** We use the power equation, $\dot{E}_K = P$, to derive the equation of motion of the bar. Now, the kinetic energy is given by

$$E_K = \frac{1}{2} \int_m v^2 dm$$

where v is the speed of the infinitesimal mass element dm . Referring to Fig. 13.76, we can write, $dm = (m/\ell)ds$, and $v = \omega s \equiv \dot{\theta}s$. Thus,

$$\begin{aligned} E_K &= \frac{1}{2} \int_0^\ell \dot{\theta}^2 s^2 \frac{m}{\ell} ds \\ &= \frac{m\dot{\theta}^2}{2\ell} \int_0^\ell s^2 ds \\ &= \frac{1}{6} m\ell^2 \dot{\theta}^2 \end{aligned}$$

and, therefore,

$$\dot{E}_K = \frac{d}{dt} \left(\frac{1}{6} m\ell^2 \omega^2 \right) = \frac{1}{3} m\ell^2 \omega \dot{\omega} = \frac{1}{3} m\ell^2 \dot{\theta} \ddot{\theta}.$$

Calculation of power (P): There are only two forces acting on the bar, the reaction force, $\vec{R} (= R_x \hat{i} + R_y \hat{j})$ and the force due to gravity, $-mg\hat{j}$. Since the support point O does not move, no work is done by \vec{R} . Therefore,

$$\begin{aligned} W &= \text{Work done by gravity force in moving from } G' \text{ to } G. \\ &= -mgh \end{aligned}$$

Note that the negative sign stands for the work done *against* gravity. Now,

$$h = OG' - OG'' = \frac{\ell}{2} - \frac{\ell}{2} \cos \theta = \frac{\ell}{2} (1 - \cos \theta).$$

Therefore,

$$W = -mg \frac{\ell}{2} (1 - \cos \theta)$$

$$\text{and } P = \dot{W} = \frac{dW}{dt} = -mg \frac{\ell}{2} \sin \theta \dot{\theta}.$$

Equating \dot{E}_K and P we get

$$-\cancel{m} g \frac{\ell}{2} \sin \theta \dot{\theta} = \frac{1}{3} \cancel{m} \ell^2 \dot{\theta} \ddot{\theta}$$

$$\text{or } \ddot{\theta} + \frac{3g}{2\ell} \sin \theta = 0.$$

$$\ddot{\theta} + \frac{3g}{2\ell} \sin \theta = 0$$

This equation is, of course, the same as we obtained using balance of angular momentum in Sample 13.22.

2. **Find ω at $\theta = 0$:** We are given that at $t = 0$, $\theta = \pi/2$ and $\dot{\theta} \equiv \omega = 0$ (released from rest). This position is (1) shown in Fig. 13.77. In position (2) $\theta = 0$, i.e., the rod is vertical. Since there are no dissipative forces, the total energy of the system remains constant. Therefore, taking datum for potential energy as shown in Fig. 13.77, we may write

$$\begin{aligned} \underbrace{E_{K1}}_0 + V_1 &= E_{K2} + \underbrace{V_2}_0 \\ \text{or } mg\frac{\ell}{2} &= \frac{1}{2} \int_m v^2 dm \\ &= \frac{1}{6} m \ell^2 \omega^2 \quad (\text{see part (a)}) \\ \Rightarrow \omega &= \pm \sqrt{\frac{3g}{\ell}} \end{aligned}$$

$$\omega = \pm \sqrt{\frac{3g}{\ell}}$$

3. **Period of small oscillations:** The equation of motion is

$$\ddot{\theta} + \frac{3g}{2\ell} \sin \theta = 0.$$

For small θ , $\sin \theta \approx \theta$

$$\begin{aligned} \Rightarrow \ddot{\theta} + \frac{3g}{2\ell} \theta &= 0 & (13.54) \\ \text{or } \ddot{\theta} + \lambda^2 \theta &= 0 \\ \text{where } \lambda^2 &= \frac{3g}{2\ell}. \end{aligned}$$

Therefore,

$$\begin{aligned} \text{the circular frequency} &= \lambda = \sqrt{\frac{3g}{2\ell}}, \\ \text{and the time period } T &= \frac{2\pi}{\lambda} = 2\pi \sqrt{\frac{2\ell}{3g}}. \end{aligned}$$

$$T = 2\pi \sqrt{\frac{2\ell}{3g}}$$

[Say for $g = 9.81 \text{ m/s}^2$, $\ell = 1 \text{ m}$ we get $\frac{T}{4} = \frac{\pi}{2} \sqrt{\frac{2}{3} \frac{1}{9.81}} \text{ s} = 0.4097 \text{ s}$]

SAMPLE 13.24 The swinging stick: numerical solution of the equation of motion. For the swinging stick considered in Samples 13.22 or 13.23, find the time that the rod takes to fall from $\theta = \pi/2$ to $\theta = 0$ if it is released from rest at $\theta = \pi/2$?

Solution $\pi/2$ is a big value of θ – big in that we cannot assume $\sin \theta \approx \theta$ (obviously $1 \neq 1.5708$). Therefore we may not use the linearized equation (13.54) to solve for t explicitly. We have to solve the full nonlinear equation (13.51) to find the required time. Unfortunately, we cannot get a *closed form* solution of this equation using mathematical skills you have at this level. Therefore, we resort to numerical integration of this equation.

Here, we show how to do this integration and find the required time using the numerical solution. We assume that we have some numerical ODE solver, say `odesolver`, available to us that will give us the numerical solution given appropriate input.

The first step in numerical integration is to set up the given differential equation of second or higher order as a set of first order ordinary differential equations. To do so for Eqn. (13.51), we introduce ω as a new variable and write

$$\dot{\theta} = \omega \quad (13.55)$$

$$\dot{\omega} = -\frac{3g}{2\ell} \sin \theta \quad (13.56)$$

Thus, the second order ODE (13.51) has been rewritten as a set of two first order ODE's (13.55) and (13.56). We may write these first order equations in vector form by assuming $[z] = [\theta \ \omega]^T$. That is,

$$\begin{aligned} [z] &= \begin{bmatrix} z_1 \\ z_2 \end{bmatrix} = \begin{bmatrix} \theta \\ \omega \end{bmatrix} \\ \Rightarrow \quad [\dot{z}] &= \begin{bmatrix} \dot{\theta} \\ \dot{\omega} \end{bmatrix} = \begin{bmatrix} z_2 \\ -\frac{3g}{2\ell} \sin z_1 \end{bmatrix} \end{aligned}$$

To use any numerical integrator, we usually need to write a small program which will compute and return the value of $[\dot{z}]$ as output if t and $[z]$ are supplied as input. Here is such a program written in pseudo-code, for our equations.

```
g = 9.81           % define constants
L = 1
ODES = { z1dot = z2
          z2dot = -3*g/(2*L) * sin(z1) }
ICS = { z1zero = pi/2
         z2zero = 0 }
solve ODES with ICS untill t = 4.
plot(t,z)         % plots t vs. theta
                  % and t vs. omega together
xlabel('t'),ylabel('theta and omega') % label axes
```

The results obtained from the numerical solution are shown in Fig. 13.78.

The problem of finding the time taken by the bar to fall from $\theta = \pi/2$ to $\theta = 0$ numerically is nontrivial. It is called a *boundary value problem*. We have only illustrated how to solve *initial value problems*. However, we can get fairly good estimate of the time just from the solution obtained.

We first plot θ against time t to get the graph shown in Fig. 13.79. We find the values of t and the corresponding values of θ that bracket $\theta = 0$. Now, we can use linear interpolation to find the value of t at $\theta = 0$. Proceeding this way, we get $t = 0.4833$ (seconds), a little more than we get from the linear ODE in sample 13.23 of 0.40975. Additionally, we can get by interpolation that at $\theta = 0$

$$\omega = -5.4246 \text{ rad/s.}$$

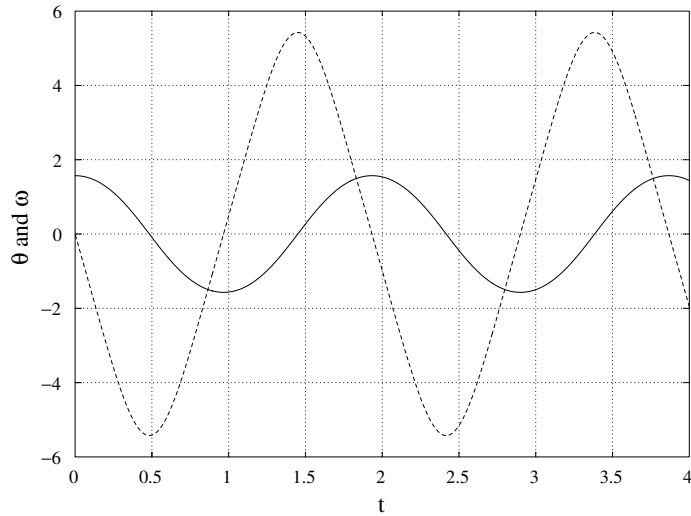

Figure 13.78: Numerical solution is shown by plotting θ and ω against time.

Filename:fig5-4-4a

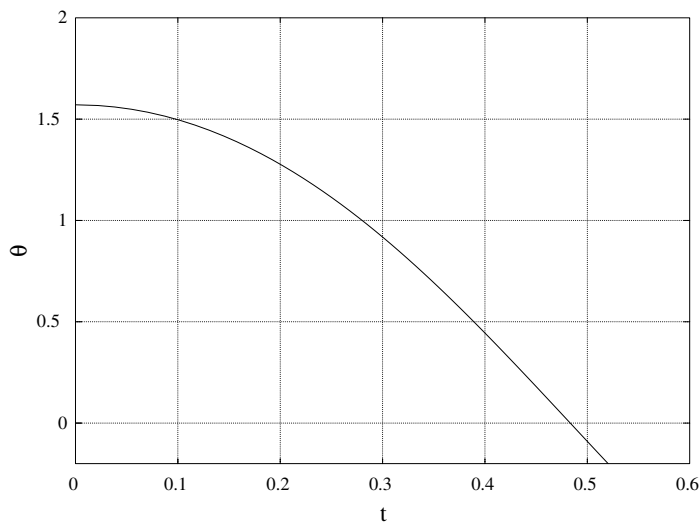

Figure 13.79: Graphic output of the plot command

Filename:fig5-4-4b

How does this result compare with the analytical value of ω from sample 13.23 (which did not depend on the small angle approximates)? Well, we found that

$$\omega = -\sqrt{\frac{3g}{\ell}} = -\sqrt{\frac{3 \cdot 9.81 \text{ m/s}^2}{1 \text{ m}}} = -5.4249 \text{ s}^{-1}.$$

Thus, we get a fairly accurate value from numerical integration!

SAMPLE 13.25 The swinging stick with a destabilizing torque.

Consider the swinging stick of Sample 13.22 once again.

1. Find the equation of motion of the stick, if a torque $\vec{M} = M\hat{k}$ is applied at end O and a force $\vec{F} = F\hat{i}$ is applied at the other end A.
2. Take $F = 0$ and $M = C\theta$. For $C = 0$ you get the equation of free oscillations obtained in Sample 13.22 or 13.23. For small C , does the period of the pendulum increase or decrease?
3. What happens if C is big?

Solution

1. A free body diagram of the bar is shown in Fig. 13.80. Once again, we can use $\sum \vec{M}_O = \dot{\vec{H}}_O$ to derive the equation of motion as in Sample 13.22. We calculated $\sum \vec{M}_O$ and $\dot{\vec{H}}_O$ in Sample 13.22. Calculation of $\dot{\vec{H}}_O$ remains the same in the present problem. We only need to recalculate $\sum \vec{M}_O$.

$$\begin{aligned}\sum \vec{M}_O &= M\hat{k} + \vec{r}_{G/O} \times mg(-\hat{j}) + \vec{r}_{A/O} \times \vec{F} \\ &= M\hat{k} - \frac{\ell}{2}mg \sin \theta \hat{k} + F\ell \cos \theta \hat{k} \\ &= (M + F\ell \cos \theta - \frac{\ell}{2}mg \sin \theta)\hat{k}\end{aligned}$$

and

$$\dot{\vec{H}}_O = m\ddot{\theta} \frac{\ell^2}{3} \hat{k} \quad (\text{see Sample 13.22})$$

Therefore, from $\sum \vec{M}_O = \dot{\vec{H}}_O$

$$\begin{aligned}M + F\ell \cos \theta - \frac{\ell}{2}mg \sin \theta &= m\ddot{\theta} \frac{\ell^2}{3} \\ \Rightarrow \ddot{\theta} + \frac{3g}{2\ell} \sin \theta - \frac{3F}{m\ell} \cos \theta - \frac{3M}{m\ell^2} &= 0.\end{aligned}$$

$$\boxed{\ddot{\theta} + \frac{3g}{2\ell} \sin \theta - \frac{3F}{m\ell} \cos \theta - \frac{3M}{m\ell^2} = 0}$$

2. Now, setting $F = 0$ and $M = C\theta$ we get

$$\ddot{\theta} + \frac{3g}{2\ell} \sin \theta - \frac{3C\theta}{m\ell^2} = 0 \quad (13.57)$$

Numerical Solution: We can numerically integrate (13.57) just as in the previous Sample to find $\theta(t)$. Here is the pseudo-code that can be used for this purpose.

```
g = 9.81, L = 1      % specify parameters
m = 1, C = 4
ODES = { thetadot = omega
          omegadot = -(3*g/(2*L)) * sin(theta)
              + 3*C/(m*L^2) * theta      }
ICS = { thetazero = pi/20
        omegazero = 0      }
solve ODES with ICS until t = 10
```

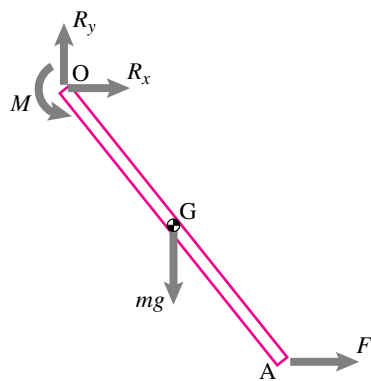

Figure 13.80: Free-body diagram of the bar with applied torque \vec{M} and force \vec{F}

Filename:fig5-4-5a

Using this pseudo-code, we find the response of the pendulum. Figure 13.81 shows different responses for various values of C . Note that for $C = 0$, it is the same case as unforced bar pendulum considered above. From Fig. 13.81 it is clear that the bar has periodic motion for small C , with the period of motion increasing with increasing values of C . It makes sense if you look at Eqn. (13.57) carefully. Gravity acts as a restoring force while the applied torque acts as a destabilizing force. Thus, with the resistance of the applied torque, the stick swings more sluggishly making its period of oscillation bigger.

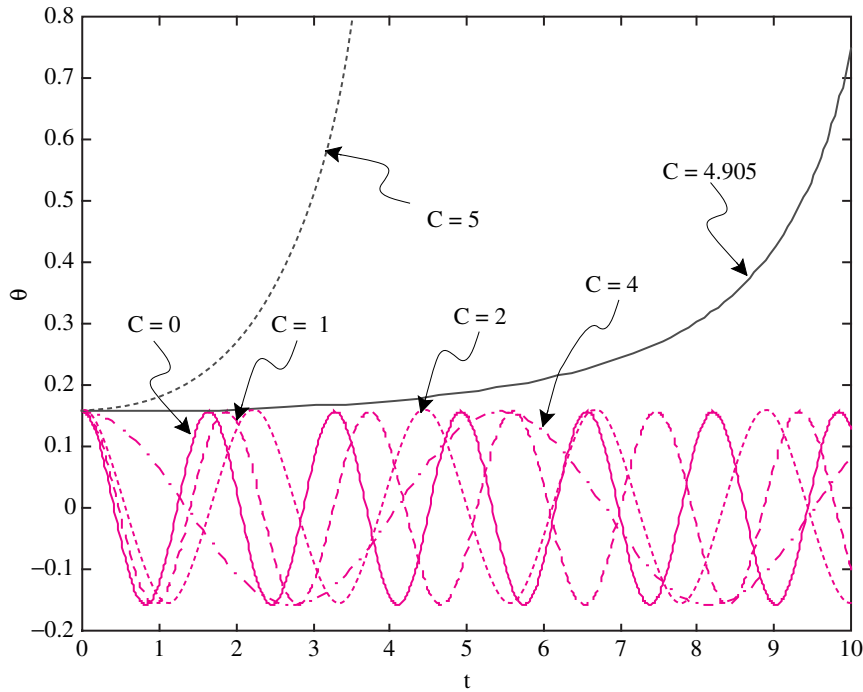

Figure 13.81: $\theta(t)$ with applied torque $M = C\theta$ for $C = 0, 1, 2, 4, 4.905, 5$. Note that for small C the motion is periodic but for large C ($C \geq 4.4$) the motion becomes aperiodic.

Filename:fig5-4-5b

- From Fig. 13.81, we see that at about $C \approx 4.9$ the stability of the system changes completely. $\theta(t)$ is not periodic anymore. It keeps on increasing at faster and faster rate, that is, the bar makes complete loops about point O with ever increasing speed. Does it make physical sense? Yes, it does. As the value of C is increased beyond a certain value (can you guess the value?), the applied torque overcomes any restoring torque due to gravity. Consequently, the bar is forced to rotate continuously in the direction of the applied force.

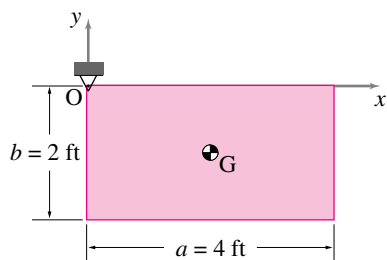

Figure 13.82: A rectangular plate is released from rest from the position shown.

Filename:fig5-4-3

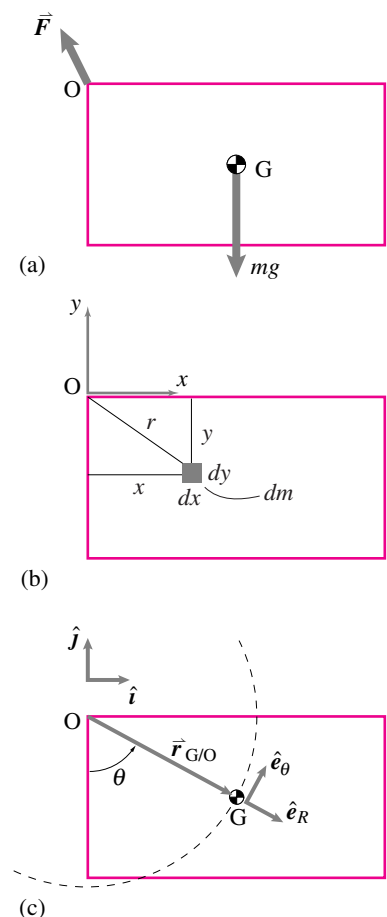

Figure 13.83: (a) The free body diagram of the plate. (b) Computation of the integral in $\dot{\vec{H}}_O = \dot{\omega} \hat{k} \int_m r^2 dm$. (c) The geometry of motion. From the given dimensions, $\hat{e}_R = \frac{a\hat{i} - b\hat{j}}{\sqrt{(a^2 + b^2)}}$, $\hat{e}_\theta = \frac{b\hat{i} + a\hat{j}}{\sqrt{(a^2 + b^2)}}$, and $r_{G/O} = \frac{\sqrt{a^2 + b^2}}{2}$.

Filename:fig5-4-3a

SAMPLE 13.26 At the onset of motion: A $2' \times 4'$ rectangular plate of mass 20 lbm is pivoted at one of its corners as shown in the figure. The plate is released from rest in the position shown. Find the force on the support immediately after release.

Solution The free body diagram of the plate is shown in Fig. 13.83. The force \vec{F} applied on the plate by the support is unknown.

The linear momentum balance for the plate gives

$$\begin{aligned} \sum \vec{F} &= m \vec{a}_G \\ \vec{F} - mg \hat{j} &= m(\ddot{\theta} r_{G/O} \hat{e}_\theta - \dot{\theta}^2 R \hat{e}_R) \\ &= m \ddot{\theta} r_{G/O} \hat{e}_\theta \quad (\text{since } \dot{\theta} = 0 \text{ at } t = 0). \end{aligned} \quad (13.58)$$

Thus to find \vec{F} we need to find $\ddot{\theta}$.

The angular momentum balance for the plate about the fixed support point O gives

$$\vec{M}_O = \dot{\vec{H}}_O$$

where

$$\begin{aligned} \vec{M}_O &= \vec{r}_{G/O} \times mg(-\hat{j}) \\ &= \underbrace{\left(\frac{a}{2}\hat{i} - \frac{b}{2}\hat{j}\right)}_{\vec{r}_{G/O}} \times mg(-\hat{j}) = -mg \frac{a}{2} \hat{k}, \end{aligned}$$

and

$$\begin{aligned} \dot{\vec{H}}_O &= \dot{\omega} \hat{k} \int_m r^2 dm = \ddot{\theta} \hat{k} \int_0^b \int_0^a \underbrace{r^2}_{(x^2 + y^2)} \underbrace{\frac{dm}{ab}}_{\frac{m}{ab}} dx dy \\ &= \frac{m(a^2 + b^2)}{3} \ddot{\theta} \hat{k}. \end{aligned}$$

Thus,

$$\begin{aligned} -mg \frac{a}{2} \hat{k} &= \frac{m(a^2 + b^2)}{3} \ddot{\theta} \hat{k} \\ \Rightarrow \ddot{\theta} &= -\frac{3ga}{2(a^2 + b^2)} \\ &= -\frac{3 \cdot 32.2 \text{ ft/s}^2 \cdot 4 \text{ ft}}{2(16 + 4) \text{ ft}^2} = -9.66 \text{ rad/s}^2. \end{aligned}$$

From eqn. (13.58), the support force is now readily calculated:

$$\begin{aligned} \vec{F} &= mg \hat{j} + m \ddot{\theta} r_{G/O} \hat{e}_\theta \\ &= mg \hat{j} + m \ddot{\theta} \frac{\sqrt{a^2 + b^2}}{2} \frac{b\hat{i} + a\hat{j}}{\sqrt{(a^2 + b^2)}} \\ &= \frac{1}{2} m \ddot{\theta} b \hat{i} + \left(mg + \frac{1}{2} m \ddot{\theta} a\right) \hat{j} \end{aligned}$$

Using the given numerical values of $m, a,$ and $b,$ $\ddot{\theta} = -9.66 \text{ rad/s}^2,$ and $g = 32.2 \text{ ft/s}^2,$ we get

$$\vec{F} = (-6\hat{i} + 8\hat{j}) \text{ lbf.}$$

$$\vec{F} = (-6\hat{i} + 8\hat{j}) \text{ lbf}$$

SAMPLE 13.27 An accelerating gear train. In the gear train shown in Fig. 13.98, the torque at the input shaft is $M_{in} = 200\text{N}\cdot\text{m}$ and the angular acceleration is $\alpha_{in} = 50\text{rad/s}^2$. The radii of the various gears are: $R_A = 5\text{ cm}$, $R_B = 8\text{ cm}$, $R_C = 4\text{ cm}$, and $R_D = 10\text{ cm}$ and the moments of inertia about the shaft axis passing through their respective centers are: $I_A = 0.1\text{ kg m}^2$, $I_{BC} = 5I_A$, $I_D = 4I_A$. Find the output torque M_{out} of the gear train.

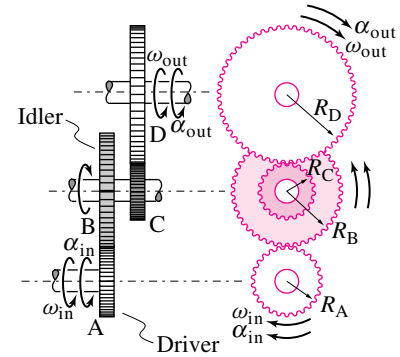

Figure 13.84: An accelerating compound gear train.

Filename:fig5-6-1

Solution Since the difference between the input power and the output power is used in accelerating the gears, we may write

$$P_{in} - P_{out} = \dot{E}_K$$

Let M_{out} be the output torque of the gear train. Then,

$$P_{in} - P_{out} = M_{in} \omega_{in} - M_{out} \omega_{out}. \quad (13.59)$$

Now,

$$\begin{aligned} \dot{E}_K &= \frac{d}{dt}(E_K) & (13.60) \\ &= \frac{d}{dt}\left(\frac{1}{2}I_A \omega_{in}^2 + \frac{1}{2}I_{BC} \omega_{BC}^2 + \frac{1}{2}I_D \omega_{out}^2\right) \\ &= I_A \omega_{in} \dot{\omega}_{in} + I_{BC} \omega_{BC} \dot{\omega}_{BC} + I_D \omega_{out} \dot{\omega}_{out} \\ &= I_A \omega_{in} \alpha_{in} + 5I_A \omega_{BC} \alpha_{BC} + 4I_A \omega_{out} \alpha_{out}. \end{aligned} \quad (13.61)$$

The different ω 's and the α 's can be related by realizing that the linear speed or the tangential acceleration of the point of contact between any two meshing gears has to be the same irrespective of which gear's speed and geometry is used to calculate it. Thus, using the linear speed and tangential acceleration calculations for points P and R in Fig. 13.99, we find

$$\begin{aligned} v_P &= \omega_{in} R_A = \omega_B R_B \\ \Rightarrow \omega_B &= \omega_{in} \cdot \frac{R_A}{R_B} \\ (a_P)_\theta &= \alpha_{in} R_A = \alpha_B R_B \\ \Rightarrow \alpha_B &= \alpha_{in} \cdot \frac{R_A}{R_B}. \end{aligned}$$

Similarly,

$$\begin{aligned} v_R &= \omega_C R_C = \omega_{out} R_D \\ \Rightarrow \omega_{out} &= \omega_C \cdot \frac{R_C}{R_D} \\ (a_R)_\theta &= \alpha_C R_C = \alpha_{out} R_D \\ \Rightarrow \alpha_{out} &= \alpha_C \cdot \frac{R_C}{R_D}. \end{aligned}$$

But

$$\begin{aligned} \omega_C &= \omega_B = \omega_{BC} \\ \Rightarrow \omega_{out} &= \omega_{in} \cdot \frac{R_A}{R_B} \cdot \frac{R_C}{R_D} \end{aligned}$$

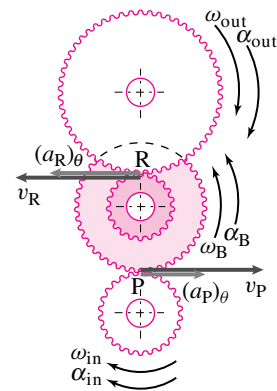

Figure 13.85: The velocity or acceleration of the point of contact between two meshing gears has to be the same irrespective of which meshing gear's geometry and motion is used to compute them.

Filename:fig5-6-1a

and

$$\begin{aligned}\alpha_C &= \alpha_B = \alpha_{BC} \\ \Rightarrow \alpha_{out} &= \alpha_{in} \cdot \frac{R_A}{R_B} \cdot \frac{R_C}{R_D}.\end{aligned}$$

Substituting these expressions for ω_{out} , α_{out} , ω_{BC} and α_{BC} in equations (13.82) and (13.84), we get

$$\begin{aligned}P_{in} - P_{out} &= M_{in} \omega_{in} - M_{out} \omega_{in} \cdot \frac{R_A}{R_B} \cdot \frac{R_C}{R_D} \\ &= \omega_{in} \left(M_{in} - M_{out} \cdot \frac{R_A}{R_B} \cdot \frac{R_C}{R_D} \right). \\ \dot{E}_K &= I_A \left[\omega_{in} \alpha_{in} + 5 \omega_{in} \alpha_{in} \left(\frac{R_A}{R_B} \right)^2 + 4 \omega_{in} \alpha_{in} \left(\frac{R_A}{R_B} \cdot \frac{R_C}{R_D} \right)^2 \right] \\ &= I_A \omega_{in} \left[\alpha_{in} + 5 \alpha_{in} \left(\frac{R_A}{R_B} \right)^2 + 4 \alpha_{in} \left(\frac{R_A}{R_B} \cdot \frac{R_C}{R_D} \right)^2 \right].\end{aligned}$$

Now equating the two quantities, $P_{in} - P_{out}$ and \dot{E}_K , and canceling ω_{in} from both sides, we obtain

$$\begin{aligned}M_{out} \frac{R_A}{R_B} \cdot \frac{R_C}{R_D} &= M_{in} - I_A \alpha_{in} \left[1 + 5 \left(\frac{R_A}{R_B} \right)^2 + 4 \left(\frac{R_A}{R_B} \cdot \frac{R_C}{R_D} \right)^2 \right] \\ M_{out} \frac{5}{8} \cdot \frac{4}{10} &= 200 \text{ N}\cdot\text{m} - 5 \text{ kg}\cdot\text{m}^2 \cdot \text{rad/s}^2 \left[1 + 5 \left(\frac{5}{8} \right)^2 + 4 \left(\frac{5}{8} \cdot \frac{4}{10} \right)^2 \right] \\ M_{out} &= 735.94 \text{ N}\cdot\text{m} \\ &\approx 736 \text{ N}\cdot\text{m}.\end{aligned}$$

$M_{out} = 736 \text{ N}\cdot\text{m}$
--

SAMPLE 13.28 Drums used as pulleys. Two drums, A and B of radii $R_o = 200\text{mm}$ and $R_i = 100\text{mm}$ are welded together. The combined mass of the drums is $M = 20\text{kg}$ and the combined moment of inertia about the z -axis passing through their common center O is $I_{zz/O} = 1.6\text{kg m}^2$. A string attached to and wrapped around drum B supports a mass $m = 2\text{kg}$. The string wrapped around drum A is pulled with a force $F = 20\text{N}$ as shown in Fig. 13.100. Assume there is no slip between the strings and the drums. Find

1. the angular acceleration of the drums,
2. the tension in the string supporting mass m , and
3. the acceleration of mass m .

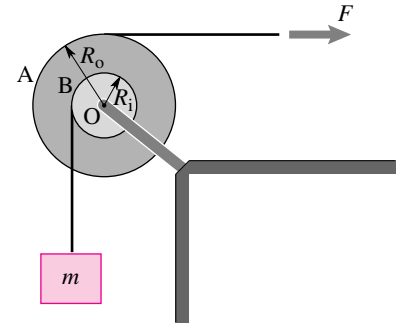

Figure 13.86: Two drums with strings wrapped around are used to pull up a mass m .

Filename:fig5-6-2

Solution The free-body diagram of the drums and the mass are shown in Fig. 13.101 separately where T is the tension in the string supporting mass m and O_x and O_y are the support reactions at O. Since the drums can only rotate about the z -axis, let

$$\vec{\omega} = \omega \hat{k} \quad \text{and} \quad \dot{\vec{\omega}} = \dot{\omega} \hat{k}.$$

Now, let us do angular momentum balance about the center of rotation O:

$$\begin{aligned} \sum \vec{M}_O &= \dot{\vec{H}}_O \\ \sum \vec{M}_O &= TR_i \hat{k} - FR_o \hat{k} \\ &= (TR_i - FR_o) \hat{k}. \end{aligned}$$

Since the motion is restricted to the xy -plane (*i.e.*, 2-D motion), the rate of change of angular momentum $\dot{\vec{H}}_O$ may be computed as

$$\begin{aligned} \dot{\vec{H}}_O &= I_{zz/cm} \dot{\omega} \hat{k} + \vec{r}_{cm/O} \times \vec{a}_{cm} M_{total} \\ &= I_{zz/O} \dot{\omega} \hat{k} + \underbrace{\vec{r}_{O/O}}_0 \times \underbrace{\vec{a}_{cm}}_0 M_{total} \\ &= I_{zz/O} \dot{\omega} \hat{k}. \end{aligned}$$

Setting $\sum \vec{M}_O = \dot{\vec{H}}_O$ we get

$$TR_i - FR_o = I_{zz/O} \dot{\omega}. \quad (13.62)$$

Now, let us write linear momentum balance, $\sum \vec{F} = m \vec{a}$, for mass m :

$$\underbrace{(T - mg)}_{\sum \vec{F}} \hat{j} = m \vec{a}.$$

Do we know anything about acceleration \vec{a} of the mass? Yes, we know its direction ($\pm \hat{j}$) and we also know that it has to be the same as the tangential acceleration

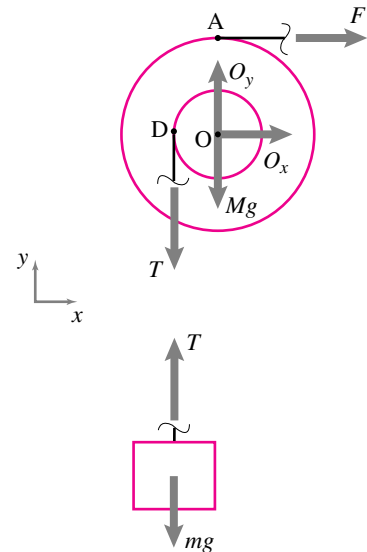

Figure 13.87: Free-body diagram of the drums and the mass m . T is the tension in the string supporting mass m and O_x and O_y are the reactions of the support at O.

Filename:fig5-6-2a

$(\vec{a}_D)_\theta$ of point D on drum B (why?). Thus,

$$\begin{aligned}\vec{a} &= (\vec{a}_D)_\theta \\ &= \dot{\omega} \hat{k} \times (-R_i \hat{i}) \\ &= -\dot{\omega} R_i \hat{j}.\end{aligned}\tag{13.63}$$

Therefore,

$$T - mg = -m\dot{\omega} R_i.\tag{13.64}$$

1. **Calculation of $\dot{\omega}$:** We now have two equations, (13.85) and (13.87), and two unknowns, $\dot{\omega}$ and T . Subtracting R_i times Eqn.(13.87) from Eqn. (13.85) we get

$$\begin{aligned}-FR_o + mgR_i &= (I_{zz/O} + mR_i^2)\dot{\omega} \\ \Rightarrow \dot{\omega} &= \frac{-FR_o + mgR_i}{(I_{zz/O} + mR_i^2)} \\ &= \frac{-20\text{ N} \cdot 0.2\text{ m} + 2\text{ kg} \cdot 9.81\text{ m/s}^2 \cdot 0.1\text{ m}}{1.6\text{ kg m}^2 + 2\text{ kg} \cdot (0.1\text{ m})^2} \\ &= \frac{-2.038\text{ kg m}^2/\text{s}^2}{1.62\text{ kg m}^2} \\ &= -1.258 \frac{1}{\text{s}^2}\end{aligned}$$

$$\dot{\omega} = -1.26 \text{ rad/s}^2 \hat{k}$$

2. **Calculation of tension T:** From equation (13.87):

$$\begin{aligned}T &= mg - m\dot{\omega} R_i \\ &= 2\text{ kg} \cdot 9.81\text{ m/s}^2 - 2\text{ kg} \cdot (-1.26\text{ s}^{-2}) \cdot 0.1\text{ m} \\ &= 19.87\text{ N}\end{aligned}$$

$$T = 19.87\text{ N}$$

3. **Calculation of acceleration of the mass:** Since the acceleration of the mass is the same as the tangential acceleration of point D on the drum, we get (from eqn. (13.86))

$$\begin{aligned}\vec{a} &= (\vec{a}_D)_\theta = -\dot{\omega} R_i \hat{j} \\ &= -(-1.26\text{ s}^{-2}) \cdot 0.1\text{ m} \\ &= 0.126\text{ m/s}^2 \hat{j}\end{aligned}$$

$$\vec{a} = 0.13\text{ m/s}^2 \hat{j}$$

Comments: It is important to understand why the acceleration of the mass is the same as the tangential acceleration of point D on the drum. We have assumed (as is common practice) that the string is massless and inextensible. Therefore each point of the string supporting the mass must have the same linear displacement, velocity, and acceleration as the mass. Now think about the point on the string which is momentarily in contact with point D of the drum. Since there is no relative slip between the drum and the string, the two points must have the same vertical acceleration. This vertical acceleration for point D on the drum is the tangential acceleration $(\vec{a}_D)_\theta$.

SAMPLE 13.29 Energy Accounting: Consider the pulley problem of Sample 13.35 again.

1. What percentage of the input energy (work done by the applied force F) is used in raising the mass by 1 m?
2. Where does the rest of the energy go? Provide an energy-balance sheet.

Solution

1. Let W_i and W_h be the input energy and the energy used in raising the mass by 1 m, respectively. Then the percentage of energy used in raising the mass is

$$\% \text{ of input energy used} = \frac{W_h}{W_i} \times 100.$$

Thus we need to calculate W_i and W_h to find the answer. W_i is the work done by the force F on the system during the interval in which the mass moves up by 1 m. Let s be the displacement of the force F during this interval. Since the displacement is in the same direction as the force (we know it is from Sample 13.35), the input-energy is

$$W_i = F s.$$

So to find W_i we need to find s .

For the mass to move up by 1 m the inner drum B must rotate by an angle θ where

$$1 \text{ m} = \theta R_i \quad \Rightarrow \quad \theta = \frac{1 \text{ m}}{0.1 \text{ m}} = 10 \text{ rad}.$$

Since the two drums, A and B, are welded together, drum A must rotate by θ as well. Therefore the displacement of force F is

$$s = \theta R_o = 10 \text{ rad} \cdot 0.2 \text{ m} = 2 \text{ m},$$

and the energy input is

$$W_i = F s = 20 \text{ N} \cdot 2 \text{ m} = 40 \text{ J}.$$

Now, the work done in raising the mass by 1 m is

$$W_h = mgh = 2 \text{ kg} \cdot 9.81 \text{ m/s}^2 \cdot 1 \text{ m} = 19.62 \text{ J}.$$

Therefore, the percentage of input-energy used in raising the mass

$$= \frac{19.62 \text{ N}\cdot\text{m}}{40} \times 100 = 49.05\% \approx 49\%.$$

2. The rest of the energy (= 51%) goes in accelerating the mass and the pulley. Let us find out how much energy goes into each of these activities. Since the initial state of the system from which we begin energy accounting is not prescribed (that is, we are not given the height of the mass from which it is to be raised 1 m, nor do we know the velocities of the mass or the pulley at that initial height), let us assume that at the initial state, the angular speed of the pulley is ω_o and the linear speed of the mass is v_o . At the end of raising the mass by 1 m from this state, let the angular speed of the pulley be ω_f and

the linear speed of the mass be v_f . Then, the energy used in accelerating the pulley is

$$\begin{aligned} (\Delta E_K)_{\text{pulley}} &= \text{final kinetic energy} - \text{initial kinetic energy} \\ &= \frac{1}{2} I \omega_f^2 - \frac{1}{2} I \omega_o^2 \\ &= \frac{1}{2} I (\omega_f^2 - \omega_o^2) \end{aligned}$$

assuming constant acceleration, $\omega_f^2 = \omega_o^2 + 2\alpha\theta$, or $\omega_f^2 - \omega_o^2 = 2\alpha\theta$.

$$\begin{aligned} &= I \alpha \theta \quad (\text{from Sample 13.39, } \alpha = 1.258 \text{ rad/s}^2.) \\ &= 1.6 \text{ kg m}^2 \cdot 1.258 \text{ rad/s}^2 \cdot 10 \text{ rad} \\ &= 20.13 \text{ N}\cdot\text{m} = 20.13 \text{ J.} \end{aligned}$$

Similarly, the energy used in accelerating the mass is

$$\begin{aligned} (\Delta E_K)_{\text{mass}} &= \text{final kinetic energy} - \text{initial kinetic energy} \\ &= \frac{1}{2} m v_f^2 - \frac{1}{2} m v_o^2 \\ &= \frac{1}{2} m (\underbrace{v_f^2 - v_o^2}_{2ah}) \\ &= mah \\ &= 2 \text{ kg} \cdot 0.126 \text{ m/s}^2 \cdot 1 \text{ m} \\ &= 0.25 \text{ J.} \end{aligned}$$

We can calculate the percentage of input energy used in these activities to get a better idea of energy allocation. Here is the summary table:

Activities	Energy Spent	
	in Joule	as % of input energy
In raising the mass by 1 m	19.62	49.05%
In accelerating the mass	0.25	0.62 %
In accelerating the pulley	20.13	50.33 %
Total	40.00	100 %

So, what would you change in the set-up so that more of the input energy is used in raising the mass? Think about what aspects of the motion would change due to your proposed design.

SAMPLE 13.30 A uniform rigid bar of mass $m = 2 \text{ kg}$ and length $\ell = 1 \text{ m}$ is pinned at one end and connected to two springs, each with spring constant k , at the other end. The bar is tweaked slightly from its vertical position. It then oscillates about its original position. The bar is timed for 20 full oscillations which take 12.5 seconds. Ignore gravity.

1. Find the equation of motion of the rod.
2. Find the spring constant k .
3. What should be the spring constant of a torsional spring if the bar is attached to one at the bottom and has the same oscillating motion characteristics?

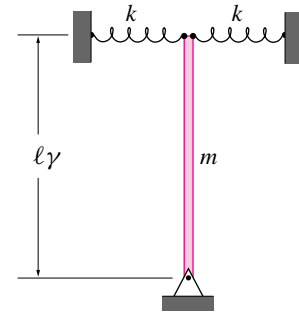

Figure 13.88:
Filename:fig10-1-2

Solution

1. Refer to the free-body diagram in figure 13.103. Angular momentum balance for the rod about point O gives

$$\sum \vec{M}_O = \dot{\vec{H}}_{/O}$$

where $\vec{M}_O = -2k \overbrace{x}^{\ell \sin \theta} \cdot \ell \cos \theta \hat{k}$
 $= -2k\ell^2 \sin \theta \cos \theta \hat{k}$,

and $\dot{\vec{H}}_{/O} = I_{zz}^O \ddot{\theta} \hat{k} = \underbrace{\frac{1}{3}m\ell^2}_{I_{zz}^O}$.

Thus

$$\frac{1}{3}m\ell^2 \ddot{\theta} = -2k\ell^2 \sin \theta \cos \theta.$$

However, for small θ , $\cos \theta \approx 1$ and $\sin \theta \approx \theta$,

$$\Rightarrow \ddot{\theta} + \frac{6k\ell^2}{m\ell^2} \theta = 0. \tag{13.65}$$

$\ddot{\theta} + \frac{6k}{m} \theta = 0$

2. Comparing Eqn. (13.88) with the standard harmonic oscillator equation $\ddot{x} + \lambda^2 x = 0$, we get

angular frequency $\lambda = \sqrt{\frac{6k}{m}}$,
 and the time period $T = \frac{2\pi}{\lambda}$
 $= 2\pi \sqrt{\frac{m}{6k}}$.

From the measured time for 20 oscillations, the time period (time for one oscillation) is

$$T = \frac{12.5}{20} \text{ s} = 0.625 \text{ s}$$

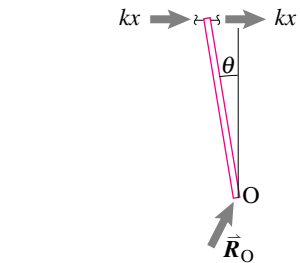
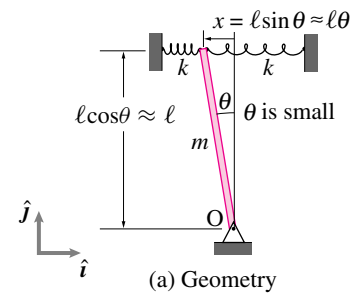

Figure 13.89:
Filename:fig10-1-2a

Now equating the measured T with the derived expression for T we get

$$\begin{aligned} 2\pi\sqrt{\frac{m}{6k}} &= 0.625 \text{ s} \\ \Rightarrow k &= 4\pi^2 \cdot \frac{m}{6(0.625 \text{ s})^2} \\ &= \frac{4\pi^2 \cdot 2 \text{ kg}}{6(0.625 \text{ s})^2} \\ &= 33.7 \text{ N/m.} \end{aligned}$$

$$k = 33.7 \text{ N/m}$$

3. If the two linear springs are to be replaced by a torsional spring at the bottom, we can find the spring constant of the torsional spring by comparison. Let k_{tor} be the spring constant of the torsional spring. Then, as shown in the free body diagram (see figure 13.104), the restoring torque applied by the spring at an angular displacement θ is $k_{\text{tor}}\theta$. Now, writing the angular momentum balance about point O, we get

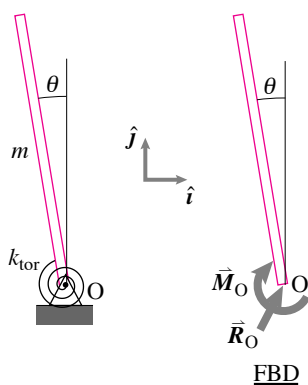

Figure 13.90:

Filename:fig10-1-2b

$$\begin{aligned} \sum \vec{M}_O &= \dot{\vec{H}}_O \\ -k_{\text{tor}}\theta\hat{k} &= I_{zz}^O(\ddot{\theta}\hat{k}) \\ \Rightarrow \ddot{\theta} + \frac{k_{\text{tor}}}{I_{zz}^O}\theta &= 0. \end{aligned}$$

Comparing with the standard harmonic equation, we find the angular frequency

$$\lambda = \sqrt{\frac{k_{\text{tor}}}{I_{zz}^O}} = \sqrt{\frac{k_{\text{tor}}}{\frac{1}{3}m\ell^2}}.$$

If this system has to have the same period of oscillation as the first system, the two angular frequencies must be equal, *i.e.*,

$$\begin{aligned} \sqrt{\frac{k_{\text{tor}}}{\frac{1}{3}m\ell^2}} &= \sqrt{\frac{6k}{m}} \\ \Rightarrow k_{\text{tor}} &= 6k \cdot \frac{1}{3}\ell^2 = 2k\ell^2 \\ &= 2 \cdot (33.7 \text{ N/m}) \cdot (1 \text{ m})^2 \\ &= 67.4 \text{ N}\cdot\text{m.} \end{aligned}$$

$$k_{\text{tor}} = 67.4 \text{ N}\cdot\text{m}$$

SAMPLE 13.31 Hey Mom, look, I can seesaw by myself. A kid, modelled as a point mass with $m = 10\text{ kg}$, is sitting at end B of a rigid rod AB of negligible mass. The rod is supported by a spring at end A and a pin at point O. The system is in static equilibrium when the rod is horizontal. Someone pushes the kid vertically downwards by a small distance y and lets go. Given that $AB = 3\text{ m}$, $AC = 0.5\text{ m}$, $k = 1\text{ kN/m}$; find

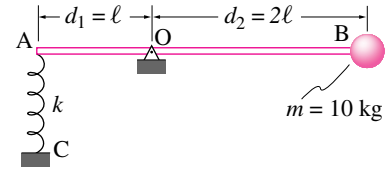

Figure 13.91:
Filename:fig3-4-3

1. the unstretched (relaxed) length of the spring,
2. the equation of motion (a differential equation relating the position of the mass to its acceleration) of the system, and
3. the natural frequency of the system.

If the rod is pinned at the midpoint instead of at O, what is the natural frequency of the system? How does the new natural frequency compare with that of a mass m simply suspended by a spring with the same spring constant?

Solution

1. **Static Equilibrium:** The FBD of the (rod + mass) system is shown in Fig. 13.106. Let the stretch in the spring in this position be y_{st} and the relaxed length of the spring be ℓ_0 . The balance of angular momentum about point O gives:

$$\begin{aligned} \sum \vec{M}_{/O} &= \dot{\vec{H}}_{/O} = \vec{0} \quad (\text{no motion}) \\ \Rightarrow (k y_{st})d_1 - (mg)d_2 &= 0 \\ \Rightarrow y_{st} &= \frac{mg}{k} \cdot \frac{d_2}{d_1} \\ &= \frac{10\text{ kg} \cdot 9.8\text{ m/s}^2 \cdot 2\ell}{1000\text{ N/m} \cdot \ell} = 0.196\text{ m} \end{aligned}$$

$$\begin{aligned} \text{Therefore, } \ell_0 &= AC - y_{st} \\ &= 0.5\text{ m} - 0.196\text{ m} = 0.304\text{ m}. \end{aligned}$$

$\ell_0 = 30.4\text{ cm}$

2. **Equation of motion:** As point B gets displaced downwards by a distance y , point A moves up by a proportionate distance y_a . From geometry, ②

$$\begin{aligned} y &\approx d_2\theta \quad \Rightarrow \quad \theta = \frac{y}{d_2} \\ y_a &\approx d_1\theta = \frac{d_1}{d_2}y \end{aligned}$$

Therefore, the total stretch in the spring, in this position,

$$\Delta y = y_a + y_{st} = \frac{d_1}{d_2}y + \frac{d_2}{d_1} \frac{mg}{k}$$

Now, Angular Momentum Balance about point O gives:

$$\begin{aligned} \sum \vec{M}_{/O} &= \dot{\vec{H}}_{/O} \\ \sum \vec{M}_{/O} &= \vec{r}_B \times mg\hat{j} + \vec{r}_A \times k\Delta y\hat{j} \\ &= (d_2mg - d_1k\Delta y)\hat{k} \end{aligned} \tag{13.66}$$

$$\dot{\vec{H}}_{/O} = \vec{r}_B \times m\vec{a} = \vec{r}_B \times m\ddot{y}\hat{j} \tag{13.67}$$

$$= d_2m\ddot{y}\hat{k} \tag{13.68}$$

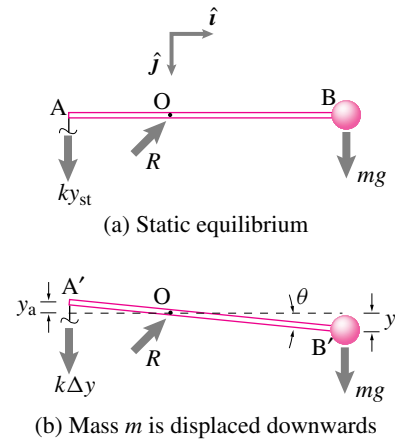

Figure 13.92: Free body diagrams
Filename:fig3-4-3a

② Here, we are considering a very small y so that we can ignore the arc the point mass B moves on and take its motion to be just vertical (i.e., $\sin \theta \approx \theta$ for small θ).

Equating (13.89) and (13.91) we get

$$\begin{aligned}
 d_2 m g - d_1 k \Delta y &= d_2 m \ddot{y} \\
 \text{or} \quad d_2 m g - d_1 k \left(\frac{d_1}{d_2} y + \frac{d_2 m g}{d_1 k} \right) &= d_2 m \ddot{y} \\
 \text{or} \quad d_2 m g - k \frac{d_1^2}{d_2} y - d_2 m g &= d_2 m \ddot{y} \\
 \text{or} \quad \ddot{y} + \frac{k}{m} \left(\frac{d_1}{d_2} \right)^2 y &= 0
 \end{aligned}$$

$$\ddot{y} + \frac{k}{m} \left(\frac{d_1}{d_2} \right)^2 y = 0$$

3. **The natural frequency of the system:** We may also write the previous equation as

$$\ddot{y} + \lambda y = 0 \quad \text{where} \quad \lambda = \frac{k}{m} \frac{d_1^2}{d_2^2}. \quad (13.69)$$

Substituting $d_1 = \ell$ and $d_2 = 2\ell$ in the expression for λ we get the natural frequency of the system

$$\sqrt{\lambda} = \frac{1}{2} \sqrt{\frac{k}{m}} = \frac{1}{2} \sqrt{\frac{1000 \text{ N/m}}{10 \text{ kg}}} = 5 \text{ s}^{-1}$$

$$\sqrt{\lambda} = 5 \text{ s}^{-1}$$

4. **Comparison with a simple spring mass system:**

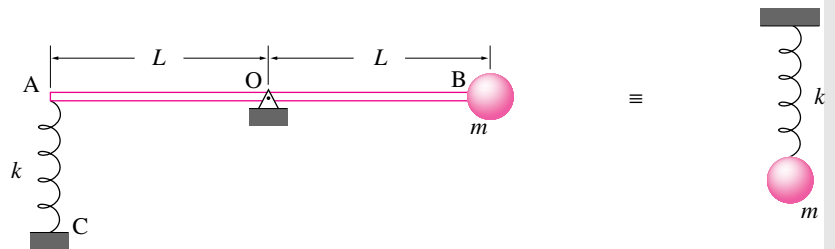

Figure 13.93:

Filename:fig3-4-3b

When $d_1 = d_2$, the equation of motion (13.92) becomes

$$\ddot{y} + \frac{k}{m} y = 0$$

and the natural frequency of the system is simply

$$\sqrt{\lambda} = \sqrt{\frac{k}{m}}$$

which corresponds to the natural frequency of a simple spring mass system shown in Fig. 13.107.

In our system (with $d_1 = d_2$) any vertical displacement of the mass at B induces an equal amount of stretch or compression in the spring which is exactly the case in the simple spring-mass system. Therefore, the two systems are mechanically equivalent. Such equivalences are widely used in modeling complex physical systems with simpler mechanical models.

SAMPLE 13.32 Energy method: Consider the pulley problem of Sample 13.35 again. Use energy method to

1. find the angular acceleration of the pulley, and
2. the acceleration of the mass.

Solution In energy method we use speeds, not velocities. Therefore, we have to be careful in our thinking about the direction of motion. In the present problem, let us assume that the pulley rotates and accelerates clockwise. Consequently, the mass moves up against gravity.

1. The energy equation we want to use is

$$P = \dot{E}_K.$$

The power P is given by $P = \sum \vec{F}_i \cdot \vec{v}_i$ where the sum is carried out over all external forces. For the mass and pulley system the external forces that do work are ③ F and mg . Therefore,

$$\begin{aligned} P &= \vec{F} \cdot \vec{v}_A + m \vec{g} \cdot \vec{v}_m \\ &= F \hat{i} \cdot v_A \hat{i} + (-mg \hat{j}) \cdot \underbrace{v_D \hat{j}}_{\vec{v}_m} \\ &= F v_A - mg v_D. \end{aligned}$$

The rate of change of kinetic energy is

$$\begin{aligned} \dot{E}_K &= \frac{d}{dt} \left(\underbrace{\frac{1}{2} m v_D^2}_{\text{K.E. of the mass}} + \underbrace{\frac{1}{2} I_{zz}^O \omega^2}_{\text{K.E. of the pulley}} \right) \\ &= m v_D \dot{v}_D + I_{zz}^O \omega \dot{\omega}. \end{aligned}$$

Now equating the power and the rate of change of kinetic energy, we get

$$F v_A - mg v_D = m v_D \dot{v}_D + I_{zz}^O \omega \dot{\omega}.$$

From kinematics, $v_A = \omega R_o$, $v_D = \omega R_i$ and $\dot{v}_D \equiv (a_D)_\theta = \dot{\omega} R_i$. Substituting these values in the above equation, we get

$$\begin{aligned} \omega(F R_o - mg R_i) &= \omega \dot{\omega} (m R_i^2 + I_{zz}^O) \\ \Rightarrow \dot{\omega} &= \frac{F R_o - mg R_i}{(I_{zz}^O + m R_i^2)} \\ &= \frac{20 \text{ N} \cdot 0.2 \text{ m} - 2 \text{ kg} \cdot 9.81 \text{ m/s}^2 \cdot 0.1 \text{ m}}{1.6 \text{ kg} \cdot \text{m}^2 + 2 \text{ kg} \cdot (0.1 \text{ m})^2} \\ &= 1.258 \frac{1}{\text{s}^2}. \quad (\text{same as the answer before.}) \end{aligned}$$

Since the sign of $\dot{\omega}$ is positive, our initial assumption of clockwise acceleration of the pulley is correct.

$$\dot{\omega} = 1.26 \text{ rad/s}^2$$

2. From kinematics,

$$a_m = (a_D)_\theta = \dot{\omega} R_i = 0.126 \text{ m/s}^2.$$

$$a_m = 0.13 \text{ m/s}^2$$

③ There are other external forces on the system: the reaction force of the support point O and the weight of the pulley—both forces acting at point O. But, since point O is stationary, these forces do no work.

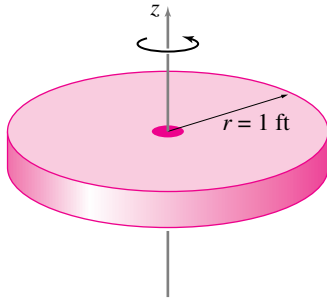

Figure 13.94:
Filename:fig7-4-1

SAMPLE 13.33 A flywheel of diameter 2 ft spins about the axis passing through its center and perpendicular to the plane of the wheel at 1000 rpm. The wheel weighs 20 lbf. Assuming the wheel to be a thin, uniform disk, find its kinetic energy.

Solution The kinetic energy of a 2-D rigid body spinning at speed ω about the z -axis passing through its mass center is

$$E_K = \frac{1}{2} I_{zz}^{\text{cm}} \omega^2$$

where I_{zz}^{cm} is the mass moment of inertia about the z -axis. For the flywheel,

$$\begin{aligned} I_{zz}^{\text{cm}} &= \frac{1}{2} m R^2 \quad (\text{from table IV at the back of the book}) \\ &= \frac{1}{2} \frac{W}{g} R^2 \quad (\text{where } W \text{ is the weight of the wheel}) \\ &= \frac{1}{2} \cdot \underbrace{\left(\frac{20 \text{ lbf}}{g} \right)}_{20 \text{ lbm}} \cdot (1 \text{ ft})^2 = 10 \text{ lbm} \cdot \text{ft}^2 \end{aligned}$$

The angular speed of the wheel is

$$\begin{aligned} \omega &= 1000 \text{ rpm} \\ &= 1000 \cdot \frac{2\pi}{60} \text{ rad/s} \\ &= 104.72 \text{ rad/s.} \end{aligned}$$

Therefore the kinetic energy of the wheel is

$$\begin{aligned} E_K &= \frac{1}{2} \cdot (10 \text{ lbm} \cdot \text{ft}^2) \cdot (104.72 \text{ rad/s})^2 \\ &= 5.483 \times 10^4 \text{ lbm} \cdot \text{ft}^2 / \text{s}^2 \\ &= \frac{5.483 \times 10^4}{32.2} \text{ lbf} \cdot \text{ft} \\ &= 1.702 \times 10^3 \text{ ft} \cdot \text{lbf.} \end{aligned}$$

$1.702 \times 10^3 \text{ ft} \cdot \text{lbf}$

13.6 Dynamics of a rigid object in planar circular motion

Our goal here is to evaluate the terms in the momentum, angular momentum, and energy balance equations for a planar object that is rotating about one point, like a part held in place by a hinge or bearing. The evaluation of forces and moments for use in the momentum and angular momentum equations is the same in statics as in the most complex dynamics, there is nothing new or special about circular motion. What we need to work out are the terms that quantify the motion of mass.

Mechanics and the motion quantities

If we can calculate the velocity and acceleration of every point in a system, we can evaluate all the momentum and energy terms in the equations of motion (inside cover), namely: \vec{L} , $\dot{\vec{L}}$, \vec{H}_C , $\dot{\vec{H}}_C$, E_K and \dot{E}_K for any reference point C of our choosing. For rotational motion these calculations are a little more complex than the special case of straight-line motion in chapter 6, where all points in a system had the same acceleration as each other.

For circular motion of a rigid object, we just well-learned in the previous section that the velocities and accelerations are

$$\begin{aligned}\vec{v} &= \vec{\omega} \times \vec{r}, \\ \vec{a} &= \dot{\vec{\omega}} \times \vec{r} + \vec{\omega} \times (\vec{\omega} \times \vec{r}), \\ &= \dot{\vec{\omega}} \times \vec{r} - \omega^2 \vec{r}\end{aligned}$$

where $\vec{\omega}$ is the angular velocity of the object relative to a fixed frame and \vec{r} is the position of a point relative to the axis of rotation. These relations apply to every point on a rotating rigid object.

Example: Spinning disk

The round flat uniform disk in figure 13.95 is in the xy plane spinning at the constant rate $\vec{\omega} = \omega \hat{k}$ about its center. It has mass m_{tot} and radius R_0 . What force is required to cause this motion? What torque? What power?

From linear momentum balance we have:

$$\sum \vec{F}_i = \dot{\vec{L}} = m_{\text{tot}} \vec{a}_{cm} = \vec{0},$$

Which we could also have calculated by evaluating the integral $\dot{\vec{L}} \equiv \int \vec{a} dm$ instead of using the general result that $\dot{\vec{L}} = m_{\text{tot}} \vec{a}_{cm}$. From angular momentum

balance we have:

$$\begin{aligned} \sum \vec{M}_{i/O} &= \dot{\vec{H}}_{/O} \\ \Rightarrow \vec{M} &= \int \vec{r}_{/O} \times \vec{a} \, dm \\ &= \int_0^{R_0} \int_0^{2\pi} (R\hat{e}_R) \times (-R\omega^2\hat{e}_R) \underbrace{\left(\frac{m_{\text{tot}}}{\pi R_0^2} \right)}_{\rho} \underbrace{R \, d\theta \, dR}_{dA} \\ &= \iint \vec{0} \, d\theta \, dR \\ &= \vec{0}. \end{aligned}$$

So the net force and moment needed are $\vec{F} = \vec{0}$ and $\vec{M} = \vec{0}$. Like a particle that moves at constant velocity with no force, a uniform disk rotates at constant rate with no torque (at least in 2D).

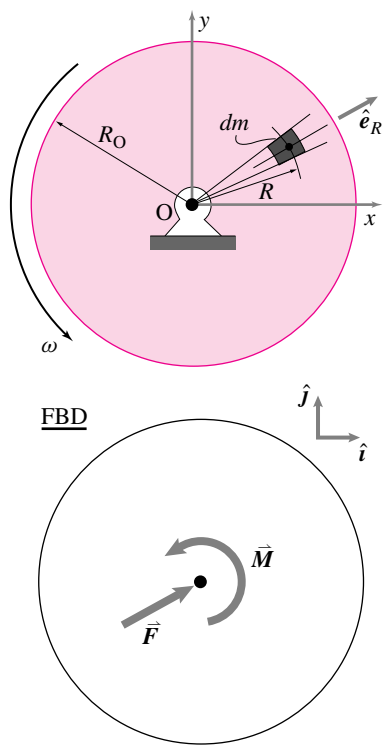

Figure 13.95: A uniform disk turned by a motor at a constant rate. The free body diagram shows a force and moment equivalent to the force system that acts including gravity, bearing forces, etc. A bit of mass dm occupies the space between the radial lines at θ and $\theta + d\theta$ and between the circles at radii R and $R + dR$.

Filename:figure4-3-motordisk

We'd now like to consider the most general case that the subject of the section allows, an arbitrarily shaped 2D rigid object with arbitrary ω and $\dot{\omega}$.

Linear momentum: \vec{L} and $\dot{\vec{L}}$

For any system in any motion we know, as we have often used, that

$$\vec{L} = m_{\text{tot}} \vec{v}_{\text{cm}} \quad \text{and} \quad \dot{\vec{L}} = m_{\text{tot}} \vec{a}_{\text{cm}}.$$

For a rigid object, the center-of-mass is a particular point G that is fixed relative to the object. So the velocity and acceleration of that point can be expressed the same way as for any other point. So, for an object in planar rotational motion about 0

$$\vec{L} = m_{\text{tot}} \vec{\omega} \times \vec{r}_{G/0}$$

and

$$\dot{\vec{L}} = m_{\text{tot}} \left(\dot{\vec{\omega}} \times \vec{r}_{G/0} - \omega^2 \vec{r}_{G/0} \right).$$

If the center-of-mass is at 0 the momentum and its rate of change are zero. But if the center-of-mass is off the axis of rotation, there must be a net force on the object with a component parallel to $\vec{r}_{0/G}$ (if $\omega \neq 0$) and a component orthogonal to $\vec{r}_{0/G}$ (if $\dot{\omega} \neq 0$). This net force need not be applied at 0 or G or any other special place on the object.

Angular momentum: $\vec{H}_{/O}$ and $\dot{\vec{H}}_{/O}$

The angular momentum itself is easy enough to calculate, using the short hand notation that \vec{r} is the position vector $\vec{r}_{/0}$ of a point relative

to point O.

$$\begin{aligned}
 \vec{H}_{/O} &= \int_{\text{all mass}} \vec{r} \times \vec{v} \, dm & \text{(a)} \\
 &= \int \vec{r} \times (\vec{\omega} \times \vec{r}) \, dm & \text{(b)} \\
 &= \omega \hat{k} \int r^2 \, dm & \text{(c)} \\
 \Rightarrow H_0 &= \omega \int r^2 \, dm. & \text{(d)}
 \end{aligned}
 \tag{13.70}$$

Here *eqn.* (13.70)c is the vector equation. But since both sides are in the \hat{k} direction we can dot both sides with \hat{k} to get the scalar moment equation *eqn.* (13.70)d, taking both M_{net} and ω as positive when counterclockwise.

To get the all important angular momentum balance equation for this system we could easily differentiate *eqn.* (13.70), taking note that the derivative is being taken relative to a fixed frame. More reliably, we use the general expression for $\dot{\vec{H}}_{/O}$ to write the angular momentum balance equation as follows.

$$\begin{aligned}
 \text{Net moment}_{/0} &= \text{rate of change of angular momentum}_{/0} & \text{(a)} \\
 \vec{M}_{\text{net}} &= \dot{\vec{H}}_{/O} & \text{(b)} \\
 &= \int_{\text{all mass}} \vec{r} \times \vec{a} \, dm & \text{(c)} \\
 &= \int \vec{r} \times (-\omega^2 \vec{r} + \dot{\omega} \hat{k} \times \vec{r}) \, dm & \text{(d)} \\
 &= \int \vec{r} \times (\dot{\omega} \hat{k} \times \vec{r}) \, dm & \text{(e)} \\
 &= \int \vec{r} \times (\dot{\omega} \hat{k} \times \vec{r}) \, dm & \text{(f)} \\
 \vec{M}_{\text{net}} &= \dot{\omega} \hat{k} \int r^2 \, dm & \text{(g)} \\
 \Rightarrow M_{\text{net}} &= \dot{\omega} \int r^2 \, dm & \text{(h)}
 \end{aligned}
 \tag{13.71}$$

We get from *eqn.* (13.71)f to *eqn.* (13.71)g by noting that \vec{r} is perpendicular to \hat{k} . Thus, using the right hand rule twice we get $\vec{r} \times (\hat{k} \times \vec{r}) = r^2 \hat{k}$.

Eqn. 13.71g and *eqn.* (13.71)h are the vector and scalar versions of the angular momentum balance equation for rotation of a planar object about 0. Repeating,

$$\vec{M}_{\text{net}} = \dot{\omega} \hat{k} \int r^2 \, dm \quad \text{and} \quad M_{\text{net}} = \dot{\omega} \int r^2 \, dm. \tag{13.72}$$

Power and Energy

Although we could treat distributed forces similarly, lets assume that there are a set of point forces applied. And, to be contrary, lets assume the mass is continuously distributed (the derivation for rigidly connected point masses would be similar). The power balance equation for one rotating rigid object is (discussed below):

$$\begin{aligned}
 \text{Net power in} &= \text{rate of change of kinetic energy} & \text{(a)} \\
 P &= \dot{E}_K & \text{(b)} \\
 \sum_{\text{all applied forces}} \vec{F}_i \cdot \vec{v}_i &= \frac{d}{dt} \int_{\text{all mass}} \frac{1}{2} v^2 dm & \text{(c)} \\
 \sum \vec{F}_i \cdot (\vec{\omega} \times \vec{r}_i) &= \frac{d}{dt} \int \frac{1}{2} (\vec{\omega} \times \vec{r}) \cdot (\vec{\omega} \times \vec{r}) dm & \text{(d)} \\
 \sum \vec{\omega} \cdot (\vec{r}_i \times \vec{F}_i) &= \frac{d}{dt} \int \frac{1}{2} \omega^2 r^2 dm & \text{(e)} \\
 \vec{\omega} \cdot \sum (\vec{r}_i \times \vec{F}_i) &= \frac{d}{dt} \left(\frac{1}{2} \omega^2 \right) \int r^2 dm & \text{(f)} \\
 \vec{\omega} \cdot \sum \vec{M}_i &= \dot{\omega} \int r^2 dm & \text{(g)} \\
 \vec{\omega} \cdot \vec{M}_{\text{tot}} &= \dot{\omega} \cdot \underbrace{\left(\vec{\omega} \int r^2 dm \right)}_{\vec{H}_{/0}} & \text{(h)}
 \end{aligned}$$

(13.73)

When not notated clearly, positions and moments are relative to the hinge at 0. Derivation 13.73 is two derivations in one. The left side about power and the right side about kinetic energy. Lets discuss one at a time.

On the left side of *eqn.* (13.73) we note in (c) that the power of each force is the dot product of the force with the velocity of the point it touches. In (d) we use what we know about the velocities of points on rotating rigid bodies. In (e) we use the vector identity $\vec{A} \cdot \vec{B} \times \vec{C} = \vec{B} \cdot \vec{C} \times \vec{A}$ from chapter 2. In (f) we note that $\vec{\omega}$ is common to all points so factors out of the sum. In (g) we note that $\vec{r} \times \vec{F}_i$ is the moment of the force about pt O. And in (g) we sum the moments of the forces. So the power of a set of forces acting on a rigid object is the product of their net moment (about 0) and the object angular velocity,

$$P = \vec{\omega} \cdot \vec{M}_{\text{tot}}. \quad (13.74)$$

On the right side of *eqn.* (13.73) we note in (c) that the kinetic energy is the sum of the kinetic energy of the mass increments. In (d) we use what we know about the velocities of these bits of mass, given that they are on a common rotating object. In (e) we use that the magnitude of the cross product of orthogonal vectors is the product of the

magnitudes ($|\vec{A} \times \vec{B}| = AB$) and that the dot product of a vector with itself is its magnitude squared ($\vec{A} \cdot \vec{A} = A^2$). In (f) we factor out ω^2 because it is common to all the mass increments and note that the remaining integral is constant in time for a rigid object. In (g) we carry out the derivative. In (h) we de-simplify the result from (g) in order to show a more general form that we will find later in 3D mechanics. Eqn. (h) follows from (g) because $\vec{\omega}$ is parallel to $\vec{\omega}$ for 2D rotations.

Note that we started here with the basic power balance equation from the front inside cover. Instead, we could have derived power balance from our angular momentum balance expression (see box 13.6 on 81).

Using moment-of-inertia in 2-D circular motion dynamics

Once one knows the velocity and acceleration of all points in a system one can find all of the motion quantities in the equations of motion by adding or integrating using the defining sums from chapter 1.1. This addition or integration is an impractical task for many motions of many objects where the required sums may involve billions and billions of atoms or a difficult integral. As you recall from chapter 3.6, the linear momentum and the rate of change of linear momentum can be calculated by just keeping track of the center-of-mass of the system of interest. One wishes for something so simple for the calculation of angular momentum.

It turns out that we are in luck if we are only interested in the two-dimensional motion of two-dimensional rigid bodies. The luck is not so great for 3-D rigid bodies but still there is some simplification. For general motion of non-rigid bodies there is no simplification to be had. The simplification is to use the moment of inertia for the bodies rather than evaluating the momenta and energy quantities as integrals

13.8 THEORY

The relation between angular momentum balance and power balance

For this system, angular momentum balance can be derived from power balance and vice versa. Thus neither is essentially more fundamental than the other and both are reliable. First we can derive power balance from angular momentum balance as follows:

$$\begin{aligned} \vec{M}_{\text{net}} &= \dot{\omega} \hat{k} \int r^2 dm \\ \vec{\omega} \cdot \vec{M}_{\text{net}} &= \vec{\omega} \cdot (\dot{\omega} \hat{k} \int r^2 dm) \\ P &= \dot{E}_K \end{aligned} \quad (13.75)$$

That is, when we dot both sides of the angular momentum equation with $\vec{\omega}$ we get on the left side a term which

we recognize as the power of the forces and on the right side a term which is the rate of change of kinetic energy.

The opposite derivation starts with the power balance *Fig. 13.73(g)*

$$\begin{aligned} \vec{\omega} \cdot \sum \vec{M}_i &= \dot{\omega} \omega \int r^2 dm \quad (\text{g}) \\ \Rightarrow \omega (\hat{k} \cdot \sum \vec{M}_i) &= \dot{\omega} \omega \int r^2 dm \\ \Rightarrow (\hat{k} \cdot \sum \vec{M}_i) &= \dot{\omega} \int r^2 dm \end{aligned} \quad (13.76)$$

and, assuming $\omega \neq 0$, divide by ω to get the angular momentum equation for planar rotational motion.

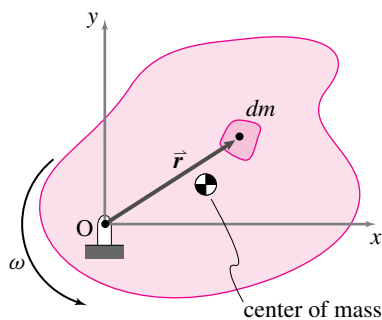

Figure 13.96: A two-dimensional body is rotating around the point O at constant rate ω . A differential bit of mass dm is shown. The center-of-mass is also shown.

Filename:figure4-2Dinertia

and sums. Of course one may have to do a sum or integral to evaluate $I \equiv I_{zz}^{cm}$ or $[I^{cm}]$ but once this calculation is done, one need not work with the integrals while worrying about the dynamics. At this point we will assume that you are comfortable calculating and looking-up moments of inertia. We proceed to use it for the purposes of studying mechanics. For constant rate rotation, we can calculate the velocity and acceleration of various points on a rigid body using $\vec{v} = \vec{\omega} \times \vec{r}$ and $\vec{a} = \vec{\omega} \times (\vec{\omega} \times \vec{r})$. So we can calculate the various motion quantities of interest: linear momentum \vec{L} , rate of change of linear momentum $\dot{\vec{L}}$, angular momentum \vec{H} , rate of change of angular momentum $\dot{\vec{H}}$, and kinetic energy E_K .

Consider a two-dimensional rigid body like that shown in figure 13.96. Now let us consider the various motion quantities in turn. First the linear momentum \vec{L} . The linear momentum of any system in any motion is $\vec{L} = \vec{v}_{cm} m_{tot}$. So, for a rigid body spinning at constant rate ω about point O (using $\vec{\omega} = \omega \hat{k}$):

$$\vec{L} = \vec{v}_{cm} m_{tot} = \vec{\omega} \times \vec{r}_{cm/o} m_{tot}.$$

Similarly, for any system, we can calculate the rate of change of linear momentum $\dot{\vec{L}}$ as $\dot{\vec{L}} = \vec{a}_{cm} m_{tot}$. So, for a rigid body spinning at constant rate,

$$\dot{\vec{L}} = \vec{a}_{cm} m_{tot} = \vec{\omega} \times (\vec{\omega} \times \vec{r}_{cm/o}) m_{tot}.$$

That is, the linear momentum is correctly calculated for this special motion, as it is for all motions, by thinking of the body as a point mass at the center-of-mass.

Unlike the calculation of linear momentum, the angular momentum turns out to be something different than would be calculated by using a point mass at the center of mass. You can remember this important fact by looking at the case when the rotation is about the center-of-mass (point O coincides with the center-of-mass). In this case one can intuitively see that the angular momentum of a rigid body *is not* zero even though the center-of-mass is not moving. Here's the calculation

formula for rate of change of angular momentum as follows:

$$\begin{aligned}
 \dot{\vec{H}}_{/O} &= \int \vec{r}_{/O} \times \vec{a} \, dm \\
 &= \int \vec{r}_{/O} \times (\vec{\omega} \times (\vec{\omega} \times \vec{r}_{/O})) \, dm \\
 &= \int (x_{/O}\hat{i} + y_{/O}\hat{j}) \times [\omega\hat{k} \times (\omega\hat{k} \times (x_{/O}\hat{i} + y_{/O}\hat{j}))] \, dm \\
 &= \vec{0}.
 \end{aligned}
 \tag{13.77}$$

Finally, we can calculate the kinetic energy by adding up $\frac{1}{2}m_i v_i^2$ for all the bits of mass on a 2-D body spinning about the z-axis:

$$E_K = \int \frac{1}{2}v^2 \, dm = \int \frac{1}{2}(\omega r)^2 \, dm = \frac{1}{2}\omega^2 \int r^2 \, dm = \frac{1}{2}I_{zz}^O \omega^2 .
 \tag{13.78}$$

If we accept the formulae presented for rigid bodies in the box at the end of chapter 7, we can find all of the motion quantities by setting $\vec{\omega} = \omega\hat{k}$ and $\vec{a} = \vec{0}$.

Example: Pendulum disk

For the disk shown in figure 13.97, we can calculate the rate of change of angular momentum about point O as

$$\begin{aligned}
 \dot{\vec{H}}_{/O} &= \vec{r}_{G/O} \times m \vec{a}_{cm} + I_{zz}^{cm} \alpha \hat{k} \\
 &= R^2 m \ddot{\theta} \hat{k} + I_{zz}^{cm} \ddot{\theta} \hat{k} \\
 &= (I_{zz}^{cm} + R^2 m) \ddot{\theta} \hat{k}.
 \end{aligned}$$

Alternatively, we could calculate directly

$$\begin{aligned}
 \dot{\vec{H}}_{/O} &= I_{zz}^O \alpha \hat{k} \\
 &= \underbrace{(I_{zz}^{cm} + R^2 m)}_{\text{by the parallel axis theorem}} \ddot{\theta} \hat{k}.
 \end{aligned}$$

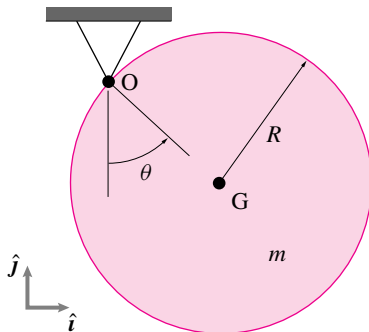

Figure 13.97:
Filename: tfigure5-3-pend-disk

But you are cautioned against falling into the common misconception that the formula $M = I\alpha$ applies in three dimensions by just thinking of the scalars as vectors and matrices. That is, the formula

$$\dot{\vec{H}}_{/O} = [I^O] \cdot \underbrace{\begin{matrix} \dot{\vec{\omega}} \\ \vec{a} \end{matrix}}_{\vec{a}}
 \tag{13.79}$$

is only correct when $\vec{\omega}$ is zero or when $\vec{\omega}$ is an eigen vector of $[I_{/O}]$. To repeat, the equation

$$\sum \text{Moments about } O = [I^O] \cdot \vec{a}
 \tag{13.80}$$

is generally wrong, it only applies if there is some known reason to neglect $\vec{\omega} \times \vec{H}_0$. For example, $\vec{\omega} \times \vec{H}_0$ can be neglected when rotation is about a principal axis as for planar bodies rotating in the plane. The term $\vec{\omega} \times \vec{H}_0$ can also be neglected at the start or stop of motion, that is when $\vec{\omega} = \vec{0}$.

The equation for linear momentum balance is the same as always, we just need to calculate the acceleration of the center-of-mass of the spinning body.

$$\dot{\vec{L}} = m_{tot} \vec{a}_{cm} = m_{tot} \left[\vec{\omega} \times (\vec{\omega} \times \vec{r}_{cm/O}) + \dot{\vec{\omega}} \times \vec{r}_{cm/O} \right] \quad (13.81)$$

Finally, the kinetic energy for a planar rigid body rotating in the plane is:

$$E_K = \frac{1}{2} \vec{\omega} \cdot ([\mathbf{I}^{cm}] \cdot \vec{\omega}) + \frac{1}{2} m \underbrace{v_{cm}^2}$$

$\vec{v}_{cm} = \vec{\omega} \times \vec{r}_{cm/O}$



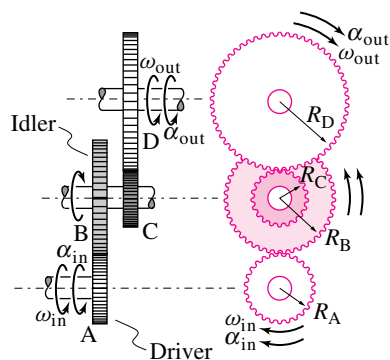

Figure 13.98: An accelerating compound gear train.

Filename:fig5-6-1

SAMPLE 13.34 An accelerating gear train. In the gear train shown in Fig. 13.98, the torque at the input shaft is $M_{in} = 200 \text{ N}\cdot\text{m}$ and the angular acceleration is $\alpha_{in} = 50 \text{ rad/s}^2$. The radii of the various gears are: $R_A = 5 \text{ cm}$, $R_B = 8 \text{ cm}$, $R_C = 4 \text{ cm}$, and $R_D = 10 \text{ cm}$ and the moments of inertia about the shaft axis passing through their respective centers are: $I_A = 0.1 \text{ kg m}^2$, $I_{BC} = 5I_A$, $I_D = 4I_A$. Find the output torque M_{out} of the gear train.

Solution Since the difference between the input power and the output power is used in accelerating the gears, we may write

$$P_{in} - P_{out} = \dot{E}_K$$

Let M_{out} be the output torque of the gear train. Then,

$$P_{in} - P_{out} = M_{in} \omega_{in} - M_{out} \omega_{out}. \quad (13.82)$$

Now,

$$\begin{aligned} \dot{E}_K &= \frac{d}{dt}(E_K) \\ &= \frac{d}{dt}\left(\frac{1}{2}I_A \omega_{in}^2 + \frac{1}{2}I_{BC} \omega_{BC}^2 + \frac{1}{2}I_D \omega_{out}^2\right) \\ &= I_A \omega_{in} \dot{\omega}_{in} + I_{BC} \omega_{BC} \dot{\omega}_{BC} + I_D \omega_{out} \dot{\omega}_{out} \\ &= I_A \omega_{in} \alpha_{in} + 5I_A \omega_{BC} \alpha_{BC} + 4I_A \omega_{out} \alpha_{out}. \end{aligned} \quad (13.84)$$

The different ω 's and the α 's can be related by realizing that the linear speed or the tangential acceleration of the point of contact between any two meshing gears has to be the same irrespective of which gear's speed and geometry is used to calculate it. Thus, using the linear speed and tangential acceleration calculations for points P and R in Fig. 13.99, we find

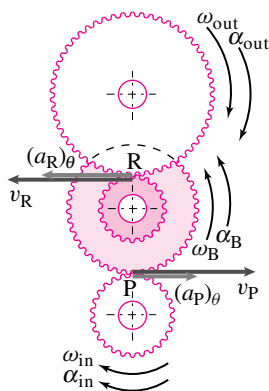

Figure 13.99: The velocity or acceleration of the point of contact between two meshing gears has to be the same irrespective of which meshing gear's geometry and motion is used to compute them.

Filename:fig5-6-1a

$$\begin{aligned} v_P &= \omega_{in} R_A = \omega_B R_B \\ \Rightarrow \omega_B &= \omega_{in} \cdot \frac{R_A}{R_B} \\ (a_P)_\theta &= \alpha_{in} R_A = \alpha_B R_B \\ \Rightarrow \alpha_B &= \alpha_{in} \cdot \frac{R_A}{R_B}. \end{aligned}$$

Similarly,

$$\begin{aligned} v_R &= \omega_C R_C = \omega_{out} R_D \\ \Rightarrow \omega_{out} &= \omega_C \cdot \frac{R_C}{R_D} \\ (a_R)_\theta &= \alpha_C R_C = \alpha_{out} R_D \\ \Rightarrow \alpha_{out} &= \alpha_C \cdot \frac{R_C}{R_D}. \end{aligned}$$

But

$$\begin{aligned} \omega_C &= \omega_B = \omega_{BC} \\ \Rightarrow \omega_{out} &= \omega_{in} \cdot \frac{R_A}{R_B} \cdot \frac{R_C}{R_D} \end{aligned}$$

and

$$\begin{aligned}\alpha_C &= \alpha_B = \alpha_{BC} \\ \Rightarrow \alpha_{out} &= \alpha_{in} \cdot \frac{R_A}{R_B} \cdot \frac{R_C}{R_D}.\end{aligned}$$

Substituting these expressions for ω_{out} , α_{out} , ω_{BC} and α_{BC} in equations (13.82) and (13.84), we get

$$\begin{aligned}P_{in} - P_{out} &= M_{in} \omega_{in} - M_{out} \omega_{in} \cdot \frac{R_A}{R_B} \cdot \frac{R_C}{R_D} \\ &= \omega_{in} \left(M_{in} - M_{out} \cdot \frac{R_A}{R_B} \cdot \frac{R_C}{R_D} \right). \\ \dot{E}_K &= I_A \left[\omega_{in} \alpha_{in} + 5 \omega_{in} \alpha_{in} \left(\frac{R_A}{R_B} \right)^2 + 4 \omega_{in} \alpha_{in} \left(\frac{R_A}{R_B} \cdot \frac{R_C}{R_D} \right)^2 \right] \\ &= I_A \omega_{in} \left[\alpha_{in} + 5 \alpha_{in} \left(\frac{R_A}{R_B} \right)^2 + 4 \alpha_{in} \left(\frac{R_A}{R_B} \cdot \frac{R_C}{R_D} \right)^2 \right].\end{aligned}$$

Now equating the two quantities, $P_{in} - P_{out}$ and \dot{E}_K , and canceling ω_{in} from both sides, we obtain

$$\begin{aligned}M_{out} \frac{R_A}{R_B} \cdot \frac{R_C}{R_D} &= M_{in} - I_A \alpha_{in} \left[1 + 5 \left(\frac{R_A}{R_B} \right)^2 + 4 \left(\frac{R_A}{R_B} \cdot \frac{R_C}{R_D} \right)^2 \right] \\ M_{out} \frac{5}{8} \cdot \frac{4}{10} &= 200 \text{ N}\cdot\text{m} - 5 \text{ kg m}^2 \cdot \text{rad/s}^2 \left[1 + 5 \left(\frac{5}{8} \right)^2 + 4 \left(\frac{5}{8} \cdot \frac{4}{10} \right)^2 \right] \\ M_{out} &= 735.94 \text{ N}\cdot\text{m} \\ &\approx 736 \text{ N}\cdot\text{m}.\end{aligned}$$

$$M_{out} = 736 \text{ N}\cdot\text{m}$$

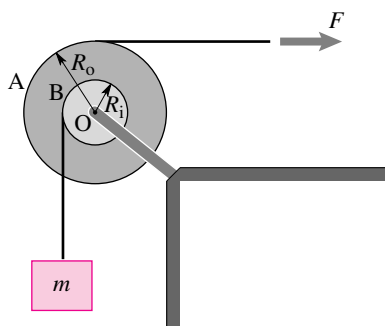

Figure 13.100: Two drums with strings wrapped around are used to pull up a mass m .

Filename:fig5-6-2

SAMPLE 13.35 Drums used as pulleys. Two drums, A and B of radii $R_o = 200\text{ mm}$ and $R_i = 100\text{ mm}$ are welded together. The combined mass of the drums is $M = 20\text{ kg}$ and the combined moment of inertia about the z -axis passing through their common center O is $I_{zz/O} = 1.6\text{ kg m}^2$. A string attached to and wrapped around drum B supports a mass $m = 2\text{ kg}$. The string wrapped around drum A is pulled with a force $F = 20\text{ N}$ as shown in Fig. 13.100. Assume there is no slip between the strings and the drums. Find

1. the angular acceleration of the drums,
2. the tension in the string supporting mass m , and
3. the acceleration of mass m .

Solution The free-body diagram of the drums and the mass are shown in Fig. 13.101 separately where T is the tension in the string supporting mass m and O_x and O_y are the support reactions at O. Since the drums can only rotate about the z -axis, let

$$\vec{\omega} = \omega \hat{k} \quad \text{and} \quad \dot{\vec{\omega}} = \dot{\omega} \hat{k}.$$

Now, let us do angular momentum balance about the center of rotation O:

$$\sum \vec{M}_O = \dot{\vec{H}}_O$$

$$\begin{aligned} \sum \vec{M}_O &= TR_i \hat{k} - FR_o \hat{k} \\ &= (TR_i - FR_o) \hat{k}. \end{aligned}$$

Since the motion is restricted to the xy -plane (*i.e.*, 2-D motion), the rate of change of angular momentum $\dot{\vec{H}}_O$ may be computed as

$$\begin{aligned} \dot{\vec{H}}_O &= I_{zz/cm} \dot{\omega} \hat{k} + \vec{r}_{cm/O} \times \vec{a}_{cm} M_{total} \\ &= I_{zz/O} \dot{\omega} \hat{k} + \underbrace{\vec{r}_{O/O}}_0 \times \underbrace{\vec{a}_{cm}}_0 M_{total} \\ &= I_{zz/O} \dot{\omega} \hat{k}. \end{aligned}$$

Setting $\sum \vec{M}_O = \dot{\vec{H}}_O$ we get

$$TR_i - FR_o = I_{zz/O} \dot{\omega}. \quad (13.85)$$

Now, let us write linear momentum balance, $\sum \vec{F} = m \vec{a}$, for mass m :

$$\underbrace{(T - mg)}_{\sum \vec{F}} \hat{j} = m \vec{a}.$$

Do we know anything about acceleration \vec{a} of the mass? Yes, we know its direction ($\pm \hat{j}$) and we also know that it has to be the same as the tangential acceleration

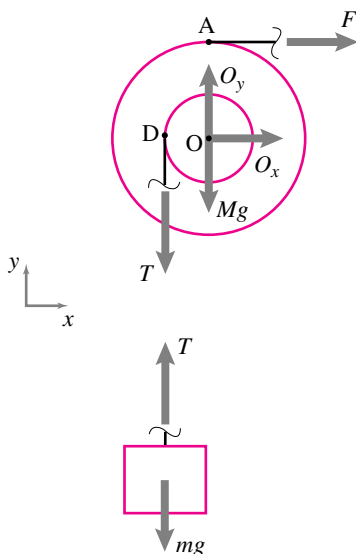

Figure 13.101: Free-body diagram of the drums and the mass m . T is the tension in the string supporting mass m and O_x and O_y are the reactions of the support at O.

Filename:fig5-6-2a

$(\vec{a}_D)_\theta$ of point D on drum B (why?). Thus,

$$\begin{aligned}\vec{a} &= (\vec{a}_D)_\theta \\ &= \dot{\omega} \hat{k} \times (-R_i \hat{i}) \\ &= -\dot{\omega} R_i \hat{j}.\end{aligned}\tag{13.86}$$

Therefore,

$$T - mg = -m\dot{\omega} R_i.\tag{13.87}$$

1. **Calculation of $\dot{\omega}$:** We now have two equations, (13.85) and (13.87), and two unknowns, $\dot{\omega}$ and T . Subtracting R_i times Eqn.(13.87) from Eqn. (13.85) we get

$$\begin{aligned}-FR_o + mgR_i &= (I_{zz/O} + mR_i^2)\dot{\omega} \\ \Rightarrow \dot{\omega} &= \frac{-FR_o + mgR_i}{(I_{zz/O} + mR_i^2)} \\ &= \frac{-20\text{ N} \cdot 0.2\text{ m} + 2\text{ kg} \cdot 9.81\text{ m/s}^2 \cdot 0.1\text{ m}}{1.6\text{ kg m}^2 + 2\text{ kg} \cdot (0.1\text{ m})^2} \\ &= \frac{-2.038\text{ kg m}^2/\text{s}^2}{1.62\text{ kg m}^2} \\ &= -1.258 \frac{1}{\text{s}^2}\end{aligned}$$

$$\dot{\omega} = -1.26 \text{ rad/s}^2 \hat{k}$$

2. **Calculation of tension T:** From equation (13.87):

$$\begin{aligned}T &= mg - m\dot{\omega} R_i \\ &= 2\text{ kg} \cdot 9.81\text{ m/s}^2 - 2\text{ kg} \cdot (-1.26\text{ s}^{-2}) \cdot 0.1\text{ m} \\ &= 19.87\text{ N}\end{aligned}$$

$$T = 19.87\text{ N}$$

3. **Calculation of acceleration of the mass:** Since the acceleration of the mass is the same as the tangential acceleration of point D on the drum, we get (from eqn. (13.86))

$$\begin{aligned}\vec{a} &= (\vec{a}_D)_\theta = -\dot{\omega} R_i \hat{j} \\ &= -(-1.26\text{ s}^{-2}) \cdot 0.1\text{ m} \\ &= 0.126\text{ m/s}^2 \hat{j}\end{aligned}$$

$$\vec{a} = 0.13\text{ m/s}^2 \hat{j}$$

Comments: It is important to understand why the acceleration of the mass is the same as the tangential acceleration of point D on the drum. We have assumed (as is common practice) that the string is massless and inextensible. Therefore each point of the string supporting the mass must have the same linear displacement, velocity, and acceleration as the mass. Now think about the point on the string which is momentarily in contact with point D of the drum. Since there is no relative slip between the drum and the string, the two points must have the same vertical acceleration. This vertical acceleration for point D on the drum is the tangential acceleration $(\vec{a}_D)_\theta$.

SAMPLE 13.36 Energy Accounting: Consider the pulley problem of Sample 13.35 again.

1. What percentage of the input energy (work done by the applied force F) is used in raising the mass by 1 m?
2. Where does the rest of the energy go? Provide an energy-balance sheet.

Solution

1. Let W_i and W_h be the input energy and the energy used in raising the mass by 1 m, respectively. Then the percentage of energy used in raising the mass is

$$\% \text{ of input energy used} = \frac{W_h}{W_i} \times 100.$$

Thus we need to calculate W_i and W_h to find the answer. W_i is the work done by the force F on the system during the interval in which the mass moves up by 1 m. Let s be the displacement of the force F during this interval. Since the displacement is in the same direction as the force (we know it is from Sample 13.35), the input-energy is

$$W_i = F s.$$

So to find W_i we need to find s .

For the mass to move up by 1 m the inner drum B must rotate by an angle θ where

$$1 \text{ m} = \theta R_i \quad \Rightarrow \quad \theta = \frac{1 \text{ m}}{0.1 \text{ m}} = 10 \text{ rad}.$$

Since the two drums, A and B, are welded together, drum A must rotate by θ as well. Therefore the displacement of force F is

$$s = \theta R_o = 10 \text{ rad} \cdot 0.2 \text{ m} = 2 \text{ m},$$

and the energy input is

$$W_i = F s = 20 \text{ N} \cdot 2 \text{ m} = 40 \text{ J}.$$

Now, the work done in raising the mass by 1 m is

$$W_h = m g h = 2 \text{ kg} \cdot 9.81 \text{ m/s}^2 \cdot 1 \text{ m} = 19.62 \text{ J}.$$

Therefore, the percentage of input-energy used in raising the mass

$$= \frac{19.62 \text{ N}\cdot\text{m}}{40} \times 100 = 49.05\% \approx 49\%.$$

2. The rest of the energy (= 51%) goes in accelerating the mass and the pulley. Let us find out how much energy goes into each of these activities. Since the initial state of the system from which we begin energy accounting is not prescribed (that is, we are not given the height of the mass from which it is to be raised 1 m, nor do we know the velocities of the mass or the pulley at that initial height), let us assume that at the initial state, the angular speed of the pulley is ω_o and the linear speed of the mass is v_o . At the end of raising the mass by 1 m from this state, let the angular speed of the pulley be ω_f and

the linear speed of the mass be v_f . Then, the energy used in accelerating the pulley is

$$\begin{aligned}
 (\Delta E_K)_{\text{pulley}} &= \text{final kinetic energy} - \text{initial kinetic energy} \\
 &= \frac{1}{2}I\omega_f^2 - \frac{1}{2}I\omega_o^2 \\
 &= \frac{1}{2}I \underbrace{(\omega_f^2 - \omega_o^2)} \\
 &= I\alpha\theta \quad (\text{from Sample 13.39, } \alpha = 1.258 \text{ rad/s}^2.) \\
 &= 1.6 \text{ kg m}^2 \cdot 1.258 \text{ rad/s}^2 \cdot 10 \text{ rad} \\
 &= 20.13 \text{ N}\cdot\text{m} = 20.13 \text{ J.}
 \end{aligned}$$

assuming constant acceleration, $\omega_f^2 = \omega_o^2 + 2\alpha\theta$, or $\omega_f^2 - \omega_o^2 = 2\alpha\theta$.

Similarly, the energy used in accelerating the mass is

$$\begin{aligned}
 (\Delta E_K)_{\text{mass}} &= \text{final kinetic energy} - \text{initial kinetic energy} \\
 &= \frac{1}{2}mv_f^2 - \frac{1}{2}mv_o^2 \\
 &= \frac{1}{2}m \underbrace{(v_f^2 - v_o^2)}_{2ah} \\
 &= mah \\
 &= 2 \text{ kg} \cdot 0.126 \text{ m/s}^2 \cdot 1 \text{ m} \\
 &= 0.25 \text{ J.}
 \end{aligned}$$

We can calculate the percentage of input energy used in these activities to get a better idea of energy allocation. Here is the summary table:

Activities	Energy Spent	
	in Joule	as % of input energy
In raising the mass by 1 m	19.62	49.05%
In accelerating the mass	0.25	0.62 %
In accelerating the pulley	20.13	50.33 %
Total	40.00	100 %

So, what would you change in the set-up so that more of the input energy is used in raising the mass? Think about what aspects of the motion would change due to your proposed design.

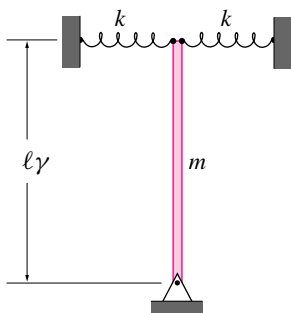

Figure 13.102:
Filename:fig10-1-2

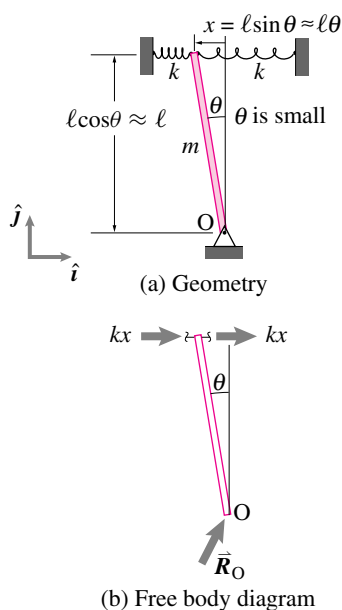

Figure 13.103:
Filename:fig10-1-2a

SAMPLE 13.37 A uniform rigid bar of mass $m = 2$ kg and length $\ell = 1$ m is pinned at one end and connected to two springs, each with spring constant k , at the other end. The bar is tweaked slightly from its vertical position. It then oscillates about its original position. The bar is timed for 20 full oscillations which take 12.5 seconds. Ignore gravity.

1. Find the equation of motion of the rod.
2. Find the spring constant k .
3. What should be the spring constant of a torsional spring if the bar is attached to one at the bottom and has the same oscillating motion characteristics?

Solution

1. Refer to the free-body diagram in figure 13.103. Angular momentum balance for the rod about point O gives

$$\sum \vec{M}_O = \dot{\vec{H}}_O$$

$$\begin{aligned} \text{where } \vec{M}_O &= -2k \overbrace{x}^{\ell \sin \theta} \cdot \ell \cos \theta \hat{k} \\ &= -2k \ell^2 \sin \theta \cos \theta \hat{k}, \end{aligned}$$

$$\text{and } \dot{\vec{H}}_O = I_{zz}^O \dot{\theta} \hat{k} = \underbrace{\frac{1}{3} m \ell^2}_{I_{zz}^O} \dot{\theta} \hat{k}.$$

Thus

$$\frac{1}{3} m \ell^2 \ddot{\theta} = -2k \ell^2 \sin \theta \cos \theta.$$

However, for small θ , $\cos \theta \approx 1$ and $\sin \theta \approx \theta$,

$$\Rightarrow \ddot{\theta} + \frac{6k \ell^2}{m \ell^2} \theta = 0. \quad (13.88)$$

$$\ddot{\theta} + \frac{6k}{m} \theta = 0$$

2. Comparing Eqn. (13.88) with the standard harmonic oscillator equation $\ddot{x} + \lambda^2 x = 0$, we get

$$\text{angular frequency } \lambda = \sqrt{\frac{6k}{m}},$$

$$\begin{aligned} \text{and the time period } T &= \frac{2\pi}{\lambda} \\ &= 2\pi \sqrt{\frac{m}{6k}}. \end{aligned}$$

From the measured time for 20 oscillations, the time period (time for one oscillation) is

$$T = \frac{12.5}{20} \text{ s} = 0.625 \text{ s}$$

Now equating the measured T with the derived expression for T we get

$$\begin{aligned} 2\pi\sqrt{\frac{m}{6k}} &= 0.625 \text{ s} \\ \Rightarrow k &= 4\pi^2 \cdot \frac{m}{6(0.625 \text{ s})^2} \\ &= \frac{4\pi^2 \cdot 2 \text{ kg}}{6(0.625 \text{ s})^2} \\ &= 33.7 \text{ N/m.} \end{aligned}$$

$$k = 33.7 \text{ N/m}$$

3. If the two linear springs are to be replaced by a torsional spring at the bottom, we can find the spring constant of the torsional spring by comparison. Let k_{tor} be the spring constant of the torsional spring. Then, as shown in the free body diagram (see figure 13.104), the restoring torque applied by the spring at an angular displacement θ is $k_{\text{tor}}\theta$. Now, writing the angular momentum balance about point O, we get

$$\begin{aligned} \sum \vec{M}_O &= \dot{\vec{H}}_O \\ -k_{\text{tor}}\theta \hat{k} &= I_{zz}^O(\ddot{\theta} \hat{k}) \\ \Rightarrow \ddot{\theta} + \frac{k_{\text{tor}}}{I_{zz}^O} \theta &= 0. \end{aligned}$$

Comparing with the standard harmonic equation, we find the angular frequency

$$\lambda = \sqrt{\frac{k_{\text{tor}}}{I_{zz}^O}} = \sqrt{\frac{k_{\text{tor}}}{\frac{1}{3}m\ell^2}}.$$

If this system has to have the same period of oscillation as the first system, the two angular frequencies must be equal, *i.e.*,

$$\begin{aligned} \sqrt{\frac{k_{\text{tor}}}{\frac{1}{3}m\ell^2}} &= \sqrt{\frac{6k}{m}} \\ \Rightarrow k_{\text{tor}} &= 6k \cdot \frac{1}{3}\ell^2 = 2k\ell^2 \\ &= 2 \cdot (33.7 \text{ N/m}) \cdot (1 \text{ m})^2 \\ &= 67.4 \text{ N}\cdot\text{m.} \end{aligned}$$

$$k_{\text{tor}} = 67.4 \text{ N}\cdot\text{m}$$

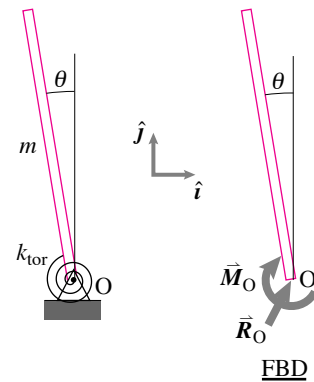

Figure 13.104:

Filename: sfig10-1-2b

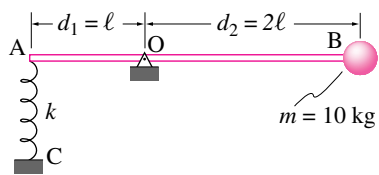

Figure 13.105:
Filename:fig3-4-3

SAMPLE 13.38 Hey Mom, look, I can seesaw by myself. A kid, modelled as a point mass with $m = 10\text{ kg}$, is sitting at end B of a rigid rod AB of negligible mass. The rod is supported by a spring at end A and a pin at point O. The system is in static equilibrium when the rod is horizontal. Someone pushes the kid vertically downwards by a small distance y and lets go. Given that $AB = 3\text{ m}$, $AC = 0.5\text{ m}$, $k = 1\text{ kN/m}$; find

1. the unstretched (relaxed) length of the spring,
2. the equation of motion (a differential equation relating the position of the mass to its acceleration) of the system, and
3. the natural frequency of the system.

If the rod is pinned at the midpoint instead of at O, what is the natural frequency of the system? How does the new natural frequency compare with that of a mass m simply suspended by a spring with the same spring constant?

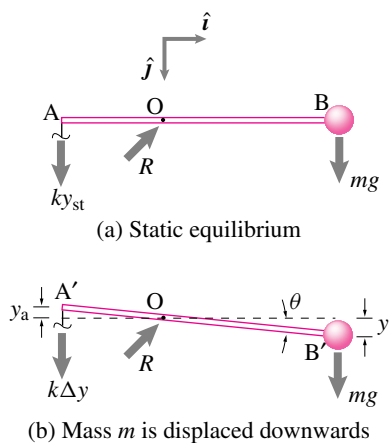

Figure 13.106: Free body diagrams
Filename:fig3-4-3a

② Here, we are considering a very small y so that we can ignore the arc the point mass B moves on and take its motion to be just vertical (i.e., $\sin \theta \approx \theta$ for small θ).

Solution

1. **Static Equilibrium:** The FBD of the (rod + mass) system is shown in Fig. 13.106. Let the stretch in the spring in this position be y_{st} and the relaxed length of the spring be ℓ_0 . The balance of angular momentum about point O gives:

$$\begin{aligned} \sum \vec{M}_{/O} &= \dot{\vec{H}}_{/O} = \vec{0} \quad (\text{no motion}) \\ \Rightarrow (k y_{st})d_1 - (mg)d_2 &= 0 \\ \Rightarrow y_{st} &= \frac{mg}{k} \cdot \frac{d_2}{d_1} \\ &= \frac{10\text{ kg} \cdot 9.8\text{ m/s}^2 \cdot 2\ell}{1000\text{ N/m} \cdot \ell} = 0.196\text{ m} \end{aligned}$$

$$\begin{aligned} \text{Therefore, } \ell_0 &= AC - y_{st} \\ &= 0.5\text{ m} - 0.196\text{ m} = 0.304\text{ m}. \end{aligned}$$

$\ell_0 = 30.4\text{ cm}$

2. **Equation of motion:** As point B gets displaced downwards by a distance y , point A moves up by a proportionate distance y_a . From geometry, ②

$$\begin{aligned} y &\approx d_2 \theta \quad \Rightarrow \quad \theta = \frac{y}{d_2} \\ y_a &\approx d_1 \theta = \frac{d_1}{d_2} y \end{aligned}$$

Therefore, the total stretch in the spring, in this position,

$$\Delta y = y_a + y_{st} = \frac{d_1}{d_2} y + \frac{d_2 mg}{d_1 k}$$

Now, Angular Momentum Balance about point O gives:

$$\begin{aligned} \sum \vec{M}_{/O} &= \dot{\vec{H}}_{/O} \\ \sum \vec{M}_{/O} &= \vec{r}_B \times mg\hat{j} + \vec{r}_A \times k\Delta y\hat{j} \\ &= (d_2 mg - d_1 k \Delta y)\hat{k} \end{aligned} \tag{13.89}$$

$$\dot{\vec{H}}_{/O} = \vec{r}_B \times m\vec{a} = \vec{r}_B \times m\ddot{y}\hat{j} \tag{13.90}$$

$$= d_2 m \ddot{y} \hat{k} \tag{13.91}$$

Equating (13.89) and (13.91) we get

$$\begin{aligned}
 d_2 m g - d_1 k \Delta y &= d_2 m \ddot{y} \\
 \text{or } d_2 m g - d_1 k \left(\frac{d_1}{d_2} y + \frac{d_2 m g}{d_1 k} \right) &= d_2 m \ddot{y} \\
 \text{or } d_2 m g - k \frac{d_1^2}{d_2} y - d_2 m g &= d_2 m \ddot{y} \\
 \text{or } \ddot{y} + \frac{k}{m} \left(\frac{d_1}{d_2} \right)^2 y &= 0
 \end{aligned}$$

$$\boxed{\ddot{y} + \frac{k}{m} \left(\frac{d_1}{d_2} \right)^2 y = 0}$$

3. **The natural frequency of the system:** We may also write the previous equation as

$$\ddot{y} + \lambda y = 0 \quad \text{where} \quad \lambda = \frac{k}{m} \frac{d_1^2}{d_2^2}. \quad (13.92)$$

Substituting $d_1 = \ell$ and $d_2 = 2\ell$ in the expression for λ we get the natural frequency of the system

$$\sqrt{\lambda} = \frac{1}{2} \sqrt{\frac{k}{m}} = \frac{1}{2} \sqrt{\frac{1000 \text{ N/m}}{10 \text{ kg}}} = 5 \text{ s}^{-1}$$

$$\boxed{\sqrt{\lambda} = 5 \text{ s}^{-1}}$$

4. **Comparison with a simple spring mass system:**

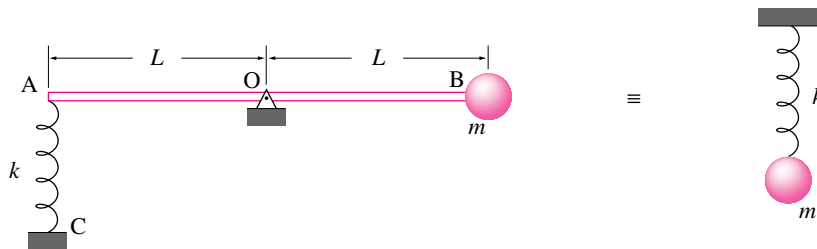

Figure 13.107:
Filename:fig3-4-3b

When $d_1 = d_2$, the equation of motion (13.92) becomes

$$\ddot{y} + \frac{k}{m} y = 0$$

and the natural frequency of the system is simply

$$\sqrt{\lambda} = \sqrt{\frac{k}{m}}$$

which corresponds to the natural frequency of a simple spring mass system shown in Fig. 13.107.

In our system (with $d_1 = d_2$) any vertical displacement of the mass at B induces an equal amount of stretch or compression in the spring which is exactly the case in the simple spring-mass system. Therefore, the two systems are mechanically equivalent. Such equivalences are widely used in modeling complex physical systems with simpler mechanical models.

SAMPLE 13.39 Energy method: Consider the pulley problem of Sample 13.35 again. Use energy method to

1. find the angular acceleration of the pulley, and
2. the acceleration of the mass.

Solution In energy method we use speeds, not velocities. Therefore, we have to be careful in our thinking about the direction of motion. In the present problem, let us assume that the pulley rotates and accelerates clockwise. Consequently, the mass moves up against gravity.

1. The energy equation we want to use is

$$P = \dot{E}_K.$$

The power P is given by $P = \sum \vec{F}_i \cdot \vec{v}_i$ where the sum is carried out over all external forces. For the mass and pulley system the external forces that do work are ③ F and mg . Therefore,

$$\begin{aligned} P &= \vec{F} \cdot \vec{v}_A + m \vec{g} \cdot \vec{v}_m \\ &= F \hat{i} \cdot v_A \hat{i} + (-mg \hat{j}) \cdot \underbrace{v_D \hat{j}}_{\vec{v}_m} \\ &= F v_A - mg v_D. \end{aligned}$$

The rate of change of kinetic energy is

$$\begin{aligned} \dot{E}_K &= \frac{d}{dt} \left(\underbrace{\frac{1}{2} m v_D^2}_{\text{K.E. of the mass}} + \underbrace{\frac{1}{2} I_{zz}^O \omega^2}_{\text{K.E. of the pulley}} \right) \\ &= m v_D \dot{v}_D + I_{zz}^O \omega \dot{\omega}. \end{aligned}$$

Now equating the power and the rate of change of kinetic energy, we get

$$F v_A - mg v_D = m v_D \dot{v}_D + I_{zz}^O \omega \dot{\omega}.$$

From kinematics, $v_A = \omega R_o$, $v_D = \omega R_i$ and $\dot{v}_D \equiv (a_D)_\theta = \dot{\omega} R_i$. Substituting these values in the above equation, we get

$$\begin{aligned} \omega(FR_o - mgR_i) &= \omega \dot{\omega}(mR_i^2 + I_{zz}^O) \\ \Rightarrow \dot{\omega} &= \frac{FR_o - mgR_i}{(I_{zz}^O + mR_i^2)} \\ &= \frac{20 \text{ N} \cdot 0.2 \text{ m} - 2 \text{ kg} \cdot 9.81 \text{ m/s}^2 \cdot 0.1 \text{ m}}{1.6 \text{ kg m}^2 + 2 \text{ kg} \cdot (0.1 \text{ m})^2} \\ &= 1.258 \frac{1}{\text{s}^2}. \quad (\text{same as the answer before.}) \end{aligned}$$

Since the sign of $\dot{\omega}$ is positive, our initial assumption of clockwise acceleration of the pulley is correct.

$$\dot{\omega} = 1.26 \text{ rad/s}^2$$

2. From kinematics,

$$a_m = (a_D)_\theta = \dot{\omega} R_i = 0.126 \text{ m/s}^2.$$

$$a_m = 0.13 \text{ m/s}^2$$

③ There are other external forces on the system: the reaction force of the support point O and the weight of the pulley—both forces acting at point O. But, since point O is stationary, these forces do no work.

SAMPLE 13.40 A flywheel of diameter 2 ft spins about the axis passing through its center and perpendicular to the plane of the wheel at 1000 rpm. The wheel weighs 20 lbf. Assuming the wheel to be a thin, uniform disk, find its kinetic energy.

Solution The kinetic energy of a 2-D rigid body spinning at speed ω about the z -axis passing through its mass center is

$$E_K = \frac{1}{2} I_{zz}^{\text{cm}} \omega^2$$

where I_{zz}^{cm} is the mass moment of inertia about the z -axis. For the flywheel,

$$\begin{aligned} I_{zz}^{\text{cm}} &= \frac{1}{2} m R^2 \quad (\text{from table IV at the back of the book}) \\ &= \frac{1}{2} \frac{W}{g} R^2 \quad (\text{where } W \text{ is the weight of the wheel}) \\ &= \frac{1}{2} \cdot \underbrace{\left(\frac{20 \text{ lbf}}{g} \right)}_{20 \text{ lbm}} \cdot (1 \text{ ft})^2 = 10 \text{ lbm} \cdot \text{ft}^2 \end{aligned}$$

The angular speed of the wheel is

$$\begin{aligned} \omega &= 1000 \text{ rpm} \\ &= 1000 \cdot \frac{2\pi}{60} \text{ rad/s} \\ &= 104.72 \text{ rad/s.} \end{aligned}$$

Therefore the kinetic energy of the wheel is

$$\begin{aligned} E_K &= \frac{1}{2} \cdot (10 \text{ lbm} \cdot \text{ft}^2) \cdot (104.72 \text{ rad/s})^2 \\ &= 5.483 \times 10^4 \text{ lbm} \cdot \text{ft}^2 / \text{s}^2 \\ &= \frac{5.483 \times 10^4}{32.2} \text{ lbf} \cdot \text{ft} \\ &= 1.702 \times 10^3 \text{ ft} \cdot \text{lbf.} \end{aligned}$$

$$1.702 \times 10^3 \text{ ft} \cdot \text{lbf}$$

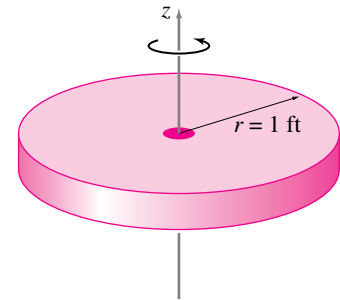

Figure 13.108:

Filename:fig7-4-1

Problems for Chapter 13

Circular motion

13.1 Kinematics of circular motion

Preparatory Problems

13.1 A particle goes on a circular path with radius $R = 5$ cm making the angle $\theta = ct$ with the positive x axis, measured counter clockwise. Assume $c = 2\pi \text{ s}^{-1}$.

- Plot the path.
- What is the angular rate in revolutions per second?
- Put a dot on the path for the location of the particle at $t = t^* = 1/6$ s.
- What are the x and y coordinates of the particle position at $t = t^*$? Mark them on your plot.
- What
- Draw the vectors \hat{e}_θ and \hat{e}_R at $t = t^*$.
- What are the x and y components of \hat{e}_R and \hat{e}_θ at $t = t^*$?
- What are the R and θ components of \hat{i} and \hat{j} at $t = t^*$?
- Draw an arrow representing both the velocity and the acceleration at $t = t^*$.
- Find the R and θ components of position \vec{r} , velocity \vec{v} and acceleration \vec{a} at $t = t^*$.
- Find the x and y components of position \vec{r} , velocity \vec{v} and acceleration \vec{a} at $t = t^*$. Find the velocity and acceleration two ways
 - by differentiating the position in x and y coordinates, and
 - by using the polar coordinate formulas for velocity and acceleration and then converting the result to Cartesian coordinates.

13.2 A bead goes around a circular track of radius 1 ft at a constant speed. It makes around the track in exactly 1 s.

- Find the speed of the bead.
- Find the magnitude of acceleration of the bead.

13.3 If a particle moves along a circle at constant rate (constant θ) following the equation

$$\vec{r}(t) = R \cos(\dot{\theta}t)\hat{i} + R \sin(\dot{\theta}t)\hat{j}$$

which of these things are true and why? If not true, explain why.

- $\vec{v} = \vec{0}$
- $\vec{v} = \text{constant}$
- $|\vec{v}| = \text{constant}$
- $\vec{a} = \vec{0}$
- $\vec{a} = \text{constant}$
- $|\vec{a}| = \text{constant}$
- $\vec{v} \perp \vec{a}$

13.4 The motion of a particle is described by the following equations:

$$\begin{aligned} x(t) &= 1 \text{ m} \cdot \cos((5 \text{ rad/s}) \cdot t), \\ y(t) &= 1 \text{ m} \cdot \sin((5 \text{ rad/s}) \cdot t). \end{aligned}$$

- Show that the speed of the particle is constant.
- There are two points marked on the path of the particle: P with coordinates (0, 1 m) and Q with coordinates (1 m, 0). How much time does the particle take to go from P to Q?
- What is the acceleration of the particle at point Q?

More-Involved Problems

13.5 A 200 mm diameter gear rotates at a constant speed of 100 rpm.

- What is the speed of a peripheral point on the gear?
- If no point on the gear is to exceed the centripetal acceleration of 25 m/s^2 , find the maximum allowable angular speed (in rpm) of the gear.

13.6 A particle executes circular motion in the xy -plane at a constant angular speed $\dot{\theta} = 2 \text{ rad/s}$. The radius of the circular path is 0.5 m. The particle's motion is tracked from the instant when $\theta = 0$, i.e., at $t = 0$, $\theta = 0$. Find the velocity and acceleration of the particle at

- $t = 0.5$ s and
- $t = 15$ s.

Draw the path and mark the position of the particle at $t = 0.5$ s and $t = 15$ s.

13.7 A particle undergoes constant rate circular motion in the xy -plane. At some instant t_0 , its velocity is $\vec{v}(t_0) = -3 \text{ m/s}\hat{i} + 4 \text{ m/s}\hat{j}$ and after 5 s the velocity is $v(t_0 + 5) = 5/\sqrt{2} \text{ m/s}(\hat{i} + \hat{j})$. If the particle has not yet completed one revolution between the two instants, find

- the angular speed of the particle,
- the distance traveled by the particle in 5 s, and
- the acceleration of the particle at the two instants.

13.8 A bead on a circular path of radius R in the xy -plane has rate of change of angular speed $\alpha = bt^2$. The bead starts from rest at $\theta = 0$.

- What is the bead's angular position θ (measured from the positive x -axis) and angular speed $\dot{\theta}$ as a function of time?
- What is the angular speed as function of angular position?

13.9 A bead on a circular wire has an angular speed given by $\dot{\theta} = c\theta^{1/2}$. The bead starts from rest at $\theta = 0$. What is the angular position and speed of the bead as a function of time? [Hint: this problem has more than one correct answer (one of which you can find with a quick guess.)]

13.10 Solve $\ddot{\theta} = C$, given $\dot{\theta}(0) = \dot{\theta}_0$, $\theta(0) = \theta_0$ and that C is a constant. That is, find θ in terms of some or all of C , $\dot{\theta}_0$, θ_0 and t .

13.11 Given that $\ddot{\theta} - \lambda^2\theta = 0$, $\theta(0) = \pi/2$, $\dot{\theta}(0) = 0$, and $\lambda = 3/s$ find the value of θ at $t = 1$ s.

13.12 Two runners run on a circular track side-by-side at the same constant angular rate $\dot{\theta} = 0.25$ rad/s about the center of the track. The inside runner is in a lane of radius $r_i = 35$ m and the outside runner is in a lane of radius $r_o = 37$ m. What is the velocity of the outside runner relative to the inside runner?

13.13 A particle oscillates on the arc of a circle with radius R according to the equation $\theta = \theta_0 \cos(\lambda t)$. What are the conditions on R , θ_0 , and λ so that the maximum acceleration in this motion occurs at $\theta = 0$. "Acceleration" here means the magnitude of the acceleration vector.

13.14 A particle moves on a circular arc starting from rest at $\theta_0 = 0$. As θ increases, the magnitude of the acceleration is constant. Assume, all in consistent units, that $R = 1$ and $|\vec{a}| = 1$.

- Write the statement 'the magnitude of acceleration is constant' as an equation in terms of $\dot{\theta}$ and $\ddot{\theta}$.
- Find a solution to the equation with the given initial conditions (analytically or numerically).
- Find and plot $\dot{\theta}$ vs t and θ vs t .
- In circular motion does $|\vec{a}| = \text{constant}$ necessarily mean that the motion is at or is gradually approaching constant rate circular motion? Is so, why? If not show a counter-example.

13.15 A particle moves in circles so that its acceleration \vec{a} always makes a fixed angle ϕ with the position vector $-\vec{r}$, with $0 \leq \phi \leq \pi/2$. For example, $\phi = 0$ would be constant rate circular motion. Assume $\phi = \pi/4$, $R = 1$ m and $\dot{\phi}_0 = 1$ rad/s. How long does it take the particle to reach

- the speed of sound (≈ 300 m/s)?
- the speed of light ($\approx 3 \cdot 10^8$ m/s)?

13.2 Dynamics of a particle in circular motion

Preparatory Problems

13.16 Force on a person standing on the equator. The total force acting on a body of mass m , moving with a constant angular speed ω on a circular path with radius r , is given by $F = m\omega^2 r$. Find the magnitude of the total force acting on a 150 lbf person standing on the equator. Neglect the motion of the earth around the sun and of the sun around the solar system, etc. The radius of the earth is 3963 mi. Give your solution in both pounds (lbf) and Newtons (N).

13.17 The acceleration of a particle in planar circular motion is given by $\vec{a} = \dot{\theta}r\hat{e}_\theta - \dot{\theta}^2 r\hat{e}_r$, where $\dot{\theta}$ is the angular acceleration, $\dot{\theta}$ is the angular speed and r is the radius of the circular path. Using $\sum \vec{F} = m\vec{a}$, find the expressions for $\sum F_x$ and $\sum F_y$ in terms of $\ddot{\theta}$, $\dot{\theta}$, r , and θ , given that $\hat{e}_r = \cos\theta\hat{i} + \sin\theta\hat{j}$ and $\hat{e}_\theta = -\sin\theta\hat{i} + \cos\theta\hat{j}$.

13.18 Consider a particle with mass m in circular motion. Let $\dot{\theta} = \alpha$, $\dot{\phi} = \omega$, and $\vec{r} = -r\hat{i}$. Let $\sum \vec{F} = \sum F_r\hat{e}_r + \sum F_\theta\hat{e}_\theta$, where $\hat{e}_r = -\hat{i}$ and $\hat{e}_\theta = \hat{k}$. Using $\sum \vec{F} = m\vec{a}$, express $\sum F_r$ and $\sum F_\theta$ in terms of α , ω , r , and m .

13.19 A bead of mass m goes around a circular path of radius R in the xy -plane with angular acceleration $\dot{\theta} = ct^3$. The bead starts from rest at $\theta = 0$.

- What is the angular momentum of the bead about the origin at $t = t_1$?
- what is the rate of change of angular momentum about the origin at $t = t_1$?
- What is the kinetic energy of the bead at $t = t_1$?
- Does the kinetic energy increase, decrease, or remain constant with time? Why?

13.20 A 200 gm particle goes in circles about a fixed center at a constant speed $v = 1.5$ m/s. It takes 7.5 s to go around the circle once.

- Find the angular speed of the particle.
- Find the magnitude of acceleration of the particle.
- Take center of the circle to be the origin of a xy -coordinate system. Find the net force on the particle when it is at $\theta = 30^\circ$ from the x -axis.

13.21 A race car cruises on a circular track at a constant speed of 120 mph. It goes around the track once in three minutes. Find the magnitude of the centripetal force on the car. What applies this force on the car? Does the driver have any control over this force?

13.22 A particle moves on a counterclockwise, origin-centered circular path in the xy -plane at a constant rate. The radius of the circle is r , the mass of the particle is m , and the particle completes one revolution in time τ .

- Neatly draw the following things:
 - The path of the particle.
 - A dot on the path when the particle is at $\theta = 0^\circ$, 90° , and 210° , where θ is measured from the x -axis (positive counterclockwise).

3. Arrows representing \hat{e}_R , \hat{e}_θ , \vec{v} , and \vec{a} at each of these points.
- b) Calculate all of the quantities in part (3) above at the points defined in part (2), (represent vector quantities in terms of the cartesian base vectors \hat{i} and \hat{j}).
- c) If this motion was imposed by the tension in a string, what would that tension be?
- d) Is radial tension enough to maintain this motion or is another force needed to keep the motion going (assuming no friction) ?
- e) Again, if this motion was imposed by the tension in a string, what is F_x , the x component of the force in the string, when $\theta = 210^\circ$? Ignore gravity.

13.23 The velocity and acceleration of a 1 kg particle, undergoing constant rate circular motion, are known at some instant t :

$$\vec{v} = -10 \text{ m/s}(\hat{i} + \hat{j}), \quad \vec{a} = 2 \text{ m/s}^2(\hat{i} - \hat{j}).$$

- a) Write the position of the particle at time t using \hat{e}_R and \hat{e}_θ base vectors.
- b) Find the net force on the particle at time t .
- c) At some later time t^* , the net force on the particle is in the $-\hat{j}$ direction. Find the elapsed time $t - t^*$.
- d) After how much time does the force on the particle reverse its direction.

13.24 A particle of mass 3 kg moves in the xy -plane so that its position is given by

$$\vec{r}(t) = 4 \text{ m} \left[\cos\left(\frac{2\pi t}{s}\right) \hat{i} + \sin\left(\frac{2\pi t}{s}\right) \hat{j} \right]$$

with respect to point O, the origin of a fixed cartesian coordinate system.

- a) What is the path of the particle? Show how you know what the path is.

- b) What is the angular velocity of the particle? Is it constant? Show how you know if it is constant or not.
- c) What is the velocity of the particle in polar coordinates?
- d) What is the speed of the particle at $t = 3 \text{ s}$?
- e) What net force does it exert on its surroundings at $t = 0 \text{ s}$? Assume the x and y axes are fixed.
- f) What is the angular momentum of the particle at $t = 3 \text{ s}$ about point O?

13.25 A comparison of constant and nonconstant rate circular motion. A 100 gm mass is going in circles of radius $R = 20 \text{ cm}$ at a constant rate $\dot{\theta} = 3 \text{ rad/s}$. Another identical mass is going in circles of the same radius but at a non-constant rate. The second mass is accelerating at $\ddot{\theta} = 2 \text{ rad/s}^2$ and at position A, it happens to have the same angular speed as the first mass.

- a) Find and draw the accelerations of the two masses (call them I and II) at position A.
- b) Find $\dot{\vec{H}}_{/O}$ for both masses at position A.
- c) Find $\vec{H}_{/O}$ for both masses at positions A and B. Do the changes in $\vec{H}_{/O}$ between the two positions reflect (qualitatively) the results obtained in (b)?
- d) If the masses are pinned to the center O by massless rigid rods, is tension in the rods enough to keep the two motions going? Explain.

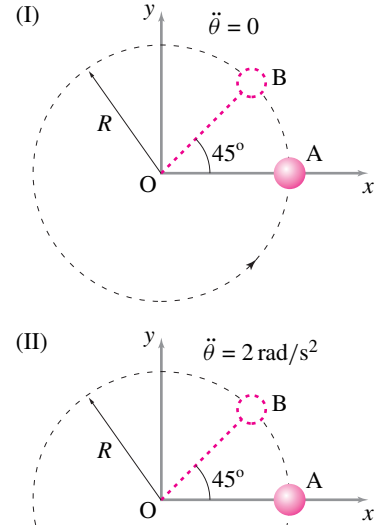

Filename: pfigure-s94h8p2

More-Involved Problems

13.26 A small mass m is connected to one end of a spring. The other end of the spring is fixed to the center of a circular track. The radius of the track is R , the unstretched length of the spring is $l_0 (< R)$, and the spring constant is k .

- a) With what speed should the mass be launched in the track so that it keeps going at a constant speed?
- b) If the spring is replaced by another spring of same relaxed length but twice the stiffness, what will be the new required launch speed of the particle?

13.27 A bead of mass m is attached to a spring of stiffness k . The bead slides without friction in the tube shown. The tube is driven at a constant angular rate $\dot{\theta}_0$ about axis AA' by a motor (not pictured). There is no gravity. The unstretched spring length is r_0 . Find the radial position r of the bead if it is stationary with respect to the rotating tube.

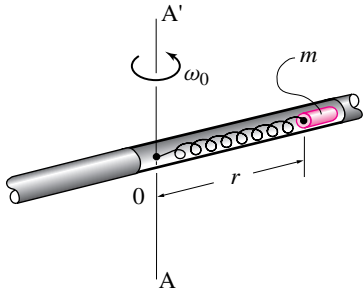

Filename:Danef94s2q6

13.28 A particle of mass m is restrained by a string to move with a constant angular speed ω around a circle of radius R on a horizontal frictionless table. If the radius of the circle is reduced to r , by pulling the string with a force F through a hole in the table, what will the particle's angular velocity be? Is kinetic energy conserved? Why or why not?

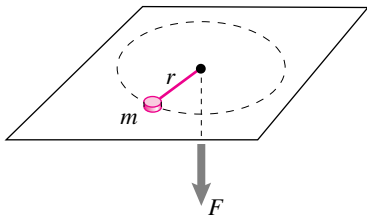

Filename:pfigure-blue-44-1

13.29 An 'L' shaped rigid, massless, and frictionless bar is made up of two uniform segments of length $\ell = 0.4\text{m}$ each. A collar of mass $m = 0.5\text{kg}$, attached to a spring at one end, slides frictionlessly on one of the arms of the 'L'. The spring is fixed to the elbow of the 'L' and has a spring constant $k = 6\text{N/m}$. The structure rotates clockwise at a constant rate $\omega = 2\text{rad/s}$. If the collar is steady at a distance $\frac{3}{4}\ell = 0.3\text{m}$ away from the elbow of the 'L', find the relaxed length of the spring, ℓ_0 . Neglect gravity.

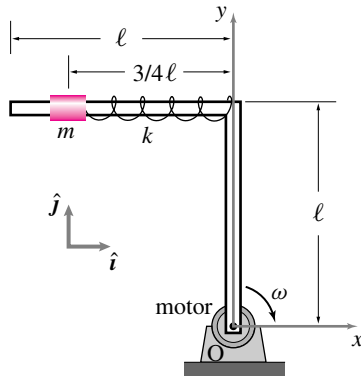

in constant rate circular motion.

Filename:pfigure-Lbar

13.30 A massless rigid rod with length ℓ attached to a ball of mass M spins at a constant angular rate ω which is maintained by a motor (not shown) at the hinge point. The rod can only withstand a tension of T_{cr} before breaking. Find the maximum angular speed of the ball so that the rod does not break assuming

- there is no gravity, and
- there is gravity (neglect bending stresses).

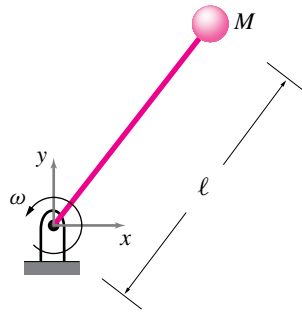

Filename:Danef94s2q5

13.31 A 1 m long massless string has a particle of 10grams mass at one end and is tied to a stationary point O at the other end. The particle rotates counter-clockwise in circles on a frictionless horizontal plane. The rotation rate is $2\pi\text{ rev/sec}$. Assume an xy -coordinate system in the plane with its origin at O .

- Make a clear sketch of the system.
- What is the tension in the string (in Newtons)?
- What is the angular momentum of the mass about O ?

- When the string makes a 45° angle with the positive x and y axis on the plane, the string is quickly and cleanly cut. What is the position of the mass 1 sec later? Make a sketch.

13.32 A ball of mass M fixed to an inextensible rod of length ℓ and negligible mass rotates about a frictionless hinge as shown in the figure. A motor (not shown) at the hinge point accelerates the mass-rod system from rest by applying a constant torque M_O . The rod is initially lined up with the positive x -axis. The rod can only withstand a tension of T_{cr} before breaking. At what time will the rod break and after how many revolutions? Include gravity if you like.

γ

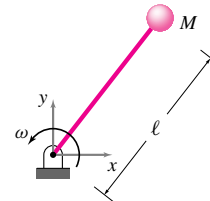

Filename:pfigure5-mike-sum95

13.33 A particle of mass m , tied to one end of a rod whose other end is fixed at point O to a motor, moves in a circular path in the vertical plane at a constant rate. Gravity acts in the $-\hat{j}$ direction.

- Find the difference between the maximum and minimum tension in the rod.
- Find the ratio $\frac{\Delta T}{T_{max}}$ where $\Delta T = T_{max} - T_{min}$. A criterion for ignoring gravity might be if the variation in tension is less than 2% of the maximum tension; i.e., when $\frac{\Delta T}{T_{max}} < 0.02$. For a given length r of the rod, find the rotation rate ω for which this condition is met.
- For $\omega = 300\text{ rpm}$, what would be the length of the rod for the condition in part (b) to be satisfied?

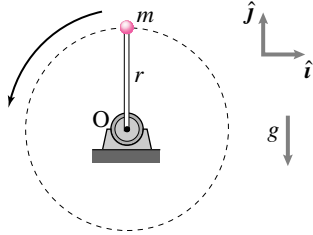

Filename:pfigure4-rph

13.34 A massless rigid bar of length L is hinged at the bottom. A force F is applied at point A at the end of the bar. A mass m is glued to the bar at point B, a distance d from the hinge. There is no gravity. What is the acceleration of point A at the instant shown? Assume the angular velocity is initially zero.

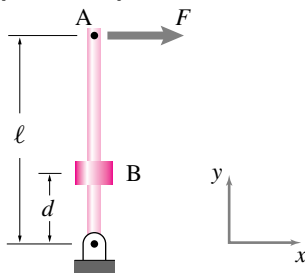

Filename:pfigure-blue-10-1

13.35 The mass m is attached rigidly to the rotating disk by the light rod AB of length ℓ . Neglect gravity. Find M_A (the moment on the rod AB from its support point at A) in terms of $\dot{\theta}$ and $\ddot{\theta}$. What is the sign of M_A if $\dot{\theta} = 0$ and $\ddot{\theta} > 0$? What is the sign if $\dot{\theta} = 0$ and $\ddot{\theta} < 0$?

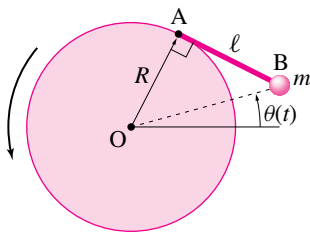

Filename:pfigure-blue-84-2

13.36 Pendula using energy methods. Find the equations of motion for the pendula in problem 13.119 using energy methods.

13.37 Tension in a simple pendulum string. A simple pendulum of length 2m with mass 3 kg is released from rest at an initial angle of 60° from the vertically down position.

- What is the tension in the string just after the pendulum is released?
- What is the tension in the string when the pendulum has reached 30° from the vertical?

13.38 Simply the simple pendulum. Find the nonlinear governing differential equation for a simple pendulum

$$\ddot{\theta} = -\frac{g}{l} \sin \theta$$

as many different ways as you can.

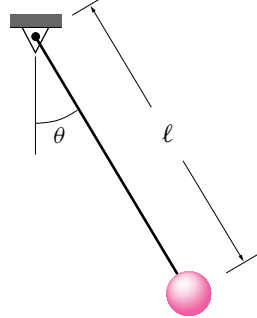

Filename:spend

simple pendulum.

13.39 Tension in a rope-swing rope. Model a swinging person as a point mass. The swing starts from rest at an angle $\theta = 90^\circ$. When the rope passes through vertical the tension in the rope is higher (it is hard to hang on). A person wants to know ahead of time if she is strong enough to hold on. How hard does she have to hang on compared, say, to her own weight? You are to find the solution two ways. Use the same m , g , and L for both solutions.

- Find $\ddot{\theta}$ as a function of g , L , θ , and m . This equation is the governing differential equation. Write it as a system of first order equations. Solve them numerically. Once you know $\dot{\theta}$ at the time the rope is vertical you can use

other mechanics relations to find the tension. If you like, you can plot the tension as a function of time as the mass falls.

- Use conservation of energy to find $\dot{\theta}$ at $\theta = 0$. Then use other mechanics relations to find the tension.

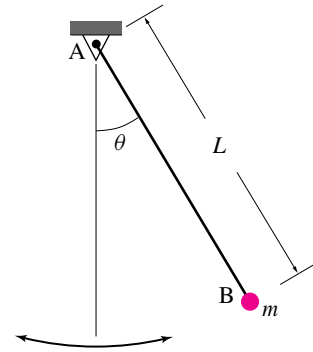

Filename:pfigure-s94h8p5

13.40 Pendulum. A pendulum with a negligible-mass rod and point mass m is released from rest at the horizontal position $\theta = \pi/2$.

- Find the acceleration (a vector) of the mass just after it is released at $\theta = \pi/2$ in terms of ℓ , m , g and any base vectors you define clearly.
- Find the acceleration (a vector) of the mass when the pendulum passes through the vertical at $\theta = 0$ in terms of ℓ , m , g and any base vectors you define clearly
- Find the string tension when the pendulum passes through the vertical at $\theta = 0$ (in terms of ℓ , m and g).

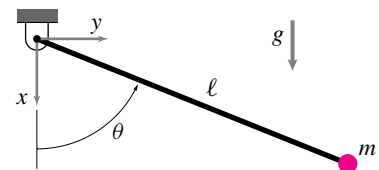

Filename:s97p2-1

13.41 Simple pendulum, extended version. A point mass $M = 1$ kg hangs on a string of length $L = 1$ m. Gravity pulls down on the mass with force Mg , where $g =$

10 m/s^2 . The pendulum lies in a vertical plane. At any time t , the angle between the pendulum and the straight-down position is $\theta(t)$. There is no air friction.

- Equation of motion.** Assuming that you know both θ and $\dot{\theta}$, find $\ddot{\theta}$. There are several ways to do this problem. Use any ways that please you.
- Tension.** Assuming that you know θ and $\dot{\theta}$, find the tension T in the string.
- Reaction components.** Assuming you know θ and $\dot{\theta}$, find the x and y components of the force that the hinge support causes on the pendulum. Define your coordinate directions sensibly.
- Reduction to first order equations.** The equation that you found in (a) is a non-linear second order ordinary differential equation. It can be changed to a pair of first order equations by defining a new variable $\alpha \equiv \dot{\theta}$. Write the equation from (a) as a pair of first order equations. Solving these equations is equivalent to solving the original second order equation.
- Numerical solution.** Given the initial conditions $\theta(t = 0) = \pi/2$ and $\alpha(t = 0) = \dot{\theta}(t = 0) = 0$, one should be able to find what the position and speed of the pendulum is as a function of time. Using the results from (b) and (c) one can also find the reaction components. Using any computer and any method you like, find: $\theta(t)$, $\dot{\theta}(t)$ & $T(t)$. Make a single plot, or three vertically aligned plots, of these variables for one full oscillation of the pendulum.
- Maximum tension.** Using your numerical solutions, find the maximum value of the tension in the rod as the mass swings.
- Period of oscillation.** How long does it take to make one oscillation?
- Other observations.** Make any observations that you

think are interesting about this problem. Some questions: Does the solution to (f) depend on the length of the string? Is the solution to (f) exactly 30 or just a number near 30? How does the period found in (g) compare to the period found by solving the linear equation $\ddot{\theta} + (g/l)\theta = 0$, based on the (inappropriate-to-use in this case) small angle approximation $\sin \theta = \theta$?

13.42 Bead on a hoop with friction.

A bead slides on a rigid, stationary, circular wire. The coefficient of friction between the bead and the wire is μ . The bead is loose on the wire (not a tight fit but not so loose that you have to worry about rattling). Assume gravity is negligible.

- Given v , m , R , & μ ; what is \dot{v} ?
- If $v(\theta = 0) = v_0$, how does v depend on θ , μ , v_0 and m ?

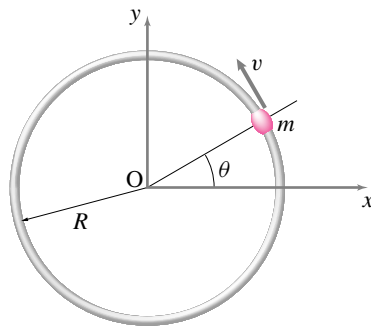

Filename:pfigure-s94h10p1

13.43 Particle in a chute. One of a million non-interacting rice grains is sliding in a circular chute with radius R . Its mass is m and it slides with coefficient of friction μ (Actually it slides, rolls and tumbles — μ is just the effective coefficient of friction from all of these interactions.) Gravity g acts downwards.

- Find a differential equation that is satisfied by θ that governs the speed of the rice as it slides down the hoop. Parameters in this equation can be m , g , R and μ [Hint: Draw FBD, write eqs of mechanics, express as ODE.]

- Find the particle speed at the bottom of the chute if $R = 0.5\text{ m}$, $m = 0.1\text{ grams}$, $g = 10\text{ m/s}^2$, and $\mu = 0.2$ as well as the initial values of $\theta_0 = 0$ and its initial downward speed is $v_0 = 10\text{ m/s}$. [Hint: you are probably best off seeking a numerical solution.]

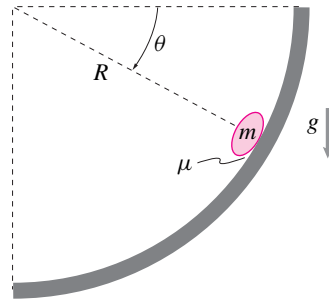

Filename:p-f96-p3-1

13.44 Due to a push which happened in the past, the collar with mass m is sliding up at speed v_0 on the circular ring when it passes through the point A. The ring is frictionless. A spring of constant k and unstretched length R is also pulling on the collar.

- What is the acceleration of the collar at A. Solve in terms of R , v_0 , m , k , g and any base vectors you define.
- What is the force on the collar from the ring when it passes point A? Solve in terms of R , v_0 , m , k , g and any base vectors you define.

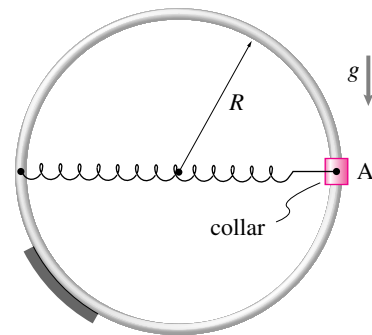

Filename:s93q4Ruina

13.45 A toy used to shoot pellets is made out of a thin tube which has a spring of spring constant k on

one end. The spring is placed in a straight section of length ℓ ; it is unstretched when its length is ℓ . The straight part is attached to a (quarter) circular tube of radius R , which points up in the air.

- A pellet of mass m is placed in the device and the spring is pulled to the left by an amount $\Delta\ell$. Ignoring friction along the travel path, what is the pellet's velocity \vec{v} as it leaves the tube?
- What force acts on the pellet just prior to its departure from the tube? What about just after?

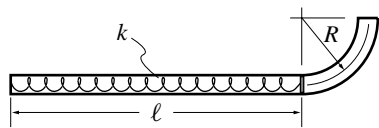

Filename:pfigure-blue-toygun

13.46 A block with mass m is moving to the right at speed v_0 when it reaches a circular frictionless portion of the ramp.

- What is the speed of the block when it reaches point B? Solve in terms of R , v_0 , m and g .
- What is the force on the block from the ramp just after it gets onto the ramp at point A? Solve in terms of R , v_0 , m and g . Remember, force is a vector.

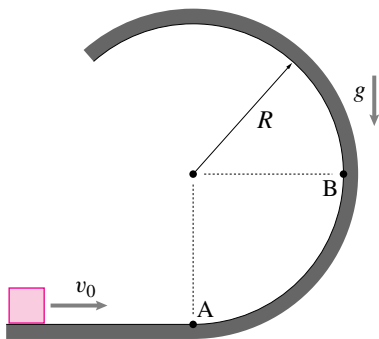

Filename:s93q4Sachse

13.47 A car moves with speed v along the surface of the hill shown which can be approximated as a circle of radius R . The car starts at a point on the hill at point O . Compute the magnitude of the speed v

such that the car just leaves the ground at the top of the hill.

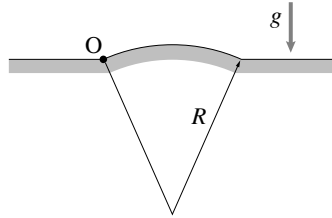

Filename:pfigure-blue-65-1

13.48 Write a computer program to solve the nonlinear pendulum equation, $\ddot{\theta} = -\frac{g}{\ell} \sin \theta$, over a given time interval $(0, t)$, and initial conditions $\theta(0)$, and $\dot{\theta}(0)$. The output should be a vector of time instants, t_i , in the given time interval and the corresponding θ_i and $\dot{\theta}_i$.

Now use your computer program to find the solution of

$$\ddot{\theta} = -\sin \theta, \quad \theta(0) = \pi/4, \quad \dot{\theta}(0) = 0.$$

Compare the solution obtained with the analytical solution of the corresponding simple pendulum equation, $\ddot{\theta} = -\theta$ with the same initial conditions. In particular,

- Find the difference in the time period of oscillations of the two systems.
- Plot $\dot{\theta}$ obtained from the two solutions against time and comment on the differences.
- Plot $\dot{\theta}$ against θ from the two solutions on the same plot and compare the two phase portraits. Comment on the differences.

13.49 Solve the nonlinear pendulum equation numerically taking 20 different initial angular positions between $\theta = 0$ and $\theta = \pi$, each time releasing the pendulum gently from rest. Find the time period of oscillation, T , from each solution and plot it against the amplitude of motion, *i.e.*, $\theta(0)$.

- How does the period of oscillation depend on the amplitude for small amplitudes?
- What is the limiting value of the time period for large amplitudes, *i.e.*, $\theta(0) \rightarrow \pi$?

- How does T depend on the amplitude over the entire range?

13.50 A pendulum of mass m and length ℓ is released from rest at $\theta(0) = 60^\circ$. It executes oscillatory motion. If the pendulum were to be released from two different positions, $\theta(0) = 45^\circ$ and $\theta(0) = 0^\circ$, with some corresponding initial angular speed such that the ensuing motion were exactly the same as that with $\theta(0) = 60^\circ$ and $\dot{\theta}(0) = 0$, find the required initial angular speeds.

- First, find the corresponding $\dot{\theta}(0)$ without any computer simulation.
- Verify your answer by plotting computer generated solutions for the three different initial conditions.
- What is the general relationship between $\theta(0)$ and $\dot{\theta}(0)$ that produces a predefined motion generated by, say, a given set of $\theta(0) = \theta_0$ and $\dot{\theta}(0) = \dot{\theta}_0$.

13.51 Use a computer program to solve the nonlinear pendulum equation, $\ddot{\theta} + \lambda^2 \sin \theta = 0$, where $\lambda^2 = 1.56/\text{s}^2$, with the following 11 initial conditions: $[\theta(0), \dot{\theta}(0)] = [1, 0], [2, 0], [3, 0], [4, -1], [-4, 1], [4, -1.02], [-4, 1.02], [4, -1.1], [-4, 1.1], [4, 1.4],$ and $[-4, 1.4]$, where θ is in radians and $\dot{\theta}$ in rad/s. Obtain each solution over the time interval $t = 0$ to $t = 20$ s.

- Plot all solutions in the phase space (*i.e.*, θ vs $\dot{\theta}$) in a single graph.
- What does the extension of the plot beyond $\theta = \pm\pi$ mean?
- Which initial conditions give solutions outside the separatrix? What do these solutions mean? Are these solutions periodic?
- If you added a little bit of viscous damping to the pendulum motion, can you guess what will happen to the solutions inside the separatrix? [Hint: think about energy associated with these solutions.]

13.3 2D rigid-object circular motion kinematics

Preparatory Problems

13.52 Give the definition of each term below in words and, but for the first, with an equation.

- rotation angle
- angular velocity
- angular acceleration

13.53 Assume that in the reference configuration, when $\theta = 0$, that the $x'y'$ axes attached to an object are aligned with the xy axes. Consider a point P attached to the moving frame (object) that has coordinates (x', y') . Find each of the quantities below in terms of some or all of $x', y', \dot{i}, \dot{j}, \theta, \dot{\theta}$.

- \vec{r}_P
- \vec{v}_P
- \vec{a}_P

13.54 Assume that in the reference configuration, when $\theta = 0$, that the $x'y'$ axes are aligned with the xy axes. Consider two points P_1 and P_2 attached to the moving frame. P_1 and P_2 have coordinates (x'_1, y'_1) and (x'_2, y'_2) . Find each of the quantities below in terms of some or all of $x'_1, y'_1, x'_2, y'_2, \dot{i}, \dot{j}, \theta, \dot{\theta}$.

- \vec{r}_{P_1/P_2}
- \vec{v}_{P_1/P_2}
- \vec{a}_{P_1/P_2}

More-Involved Problems

13.55 Find $\vec{v} = \vec{\omega} \times \vec{r}$, if $\vec{\omega} = 1.5 \text{ rad/s} \hat{k}$ and $\vec{r} = 2 \text{ m} \hat{i} - 3 \text{ m} \hat{j}$.

13.56 A rod OB rotates with its end O fixed as shown in the figure with angular velocity $\vec{\omega} = 5 \text{ rad/s} \hat{k}$ and angular acceleration $\vec{\alpha} = 2 \text{ rad/s}^2 \hat{k}$ at the moment of interest. Find, draw, and label the tangential and normal acceleration of end point B given that $\theta = 60^\circ$.

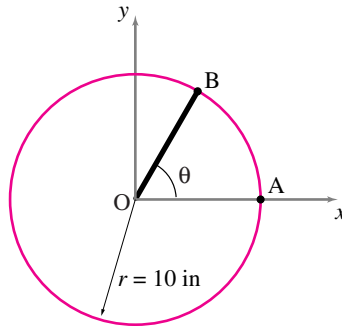

Filename:efig1-2-18

13.57 A motor turns a uniform disc of radius R counter-clockwise about its mass center at a constant rate ω . The disc lies in the xy -plane and its angular displacement θ is measured (positive counter-clockwise) from the x -axis. What is the angular displacement $\theta(t)$ of the disc if it starts at $\theta(0) = \theta_0$ and $\dot{\theta}(0) = \omega$? What are the velocity and acceleration of a point P at position $\vec{r} = x\hat{i} + y\hat{j}$?

13.58 A disc rotates at 15 rpm. How many seconds does it take to rotate by 180 degrees? What is the angular speed of the disc in rad/s?

13.59 Two discs \mathcal{A} and \mathcal{B} rotate at constant speeds about their centers. Disc \mathcal{A} rotates at 100 rpm and disc \mathcal{B} rotates at 10 rad/s. Which is rotating faster?

13.60 Find the angular velocities of the second, minute, and hour hands of a clock.

13.61 A motor turns a uniform disc of radius R counter-clockwise about its mass center at a constant rate ω . The disc lies in the xy -plane and its

angular displacement θ is measured (positive counter-clockwise) from the x -axis. What are the velocity and acceleration of a point P at position $\vec{r}_P = c\hat{i} + d\hat{j}$ relative to the velocity and acceleration of a point Q at position $\vec{r}_Q = 0.5(-d\hat{i} + c\hat{j})$ on the disk? ($c^2 + d^2 < R^2$.)

13.62 A 0.4 m long rod AB has many holes along its length such that it can be pegged at any of the various locations. It rotates counter-clockwise at a constant angular speed about a peg whose location is not known. At some instant t , the velocity of end B is $\vec{v}_B = -3 \text{ m/s} \hat{j}$. After $\frac{\pi}{20}$ s, the velocity of end B is $\vec{v}_B = -3 \text{ m/s} \hat{i}$. If the rod has not completed one revolution during this period,

- find the angular velocity of the rod, and
- find the location of the peg along the length of the rod.

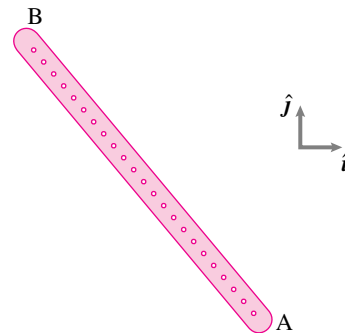

Filename:pffigure4-3-rp9

13.63 A circular disc of radius $r = 250 \text{ mm}$ rotates in the xy -plane about a point which is at a distance $d = 2r$ away from the center of the disk. At the instant of interest, the linear speed of the center C is 0.60 m/s and the magnitude of its centripetal acceleration is 0.72 m/s^2 .

- Find the rotational speed of the disk.
- Is the given information enough to locate the center of rotation of the disk?
- If the acceleration of the center has no component in the \hat{j} direction at the moment of interest, can you locate the center of rotation? If yes, is the

point you locate unique? If not, what other information is required to make the point unique?

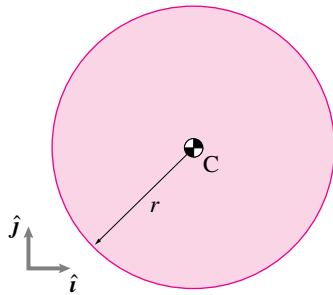

Filename:pfigure4-3-rp8

13.64 A disc C spins at a constant rate of two revolutions per second counter-clockwise about its geometric center, G , which is fixed. A point P is marked on the disk at a radius of one meter. At the moment of interest, point P is on the x -axis of an xy -coordinate system centered at point G .

- Draw a neat diagram showing the disk, the particle, and the coordinate axes.
- What is the angular velocity of the disk, $\vec{\omega}_C$?
- What is the angular acceleration of the disk, $\vec{\alpha}_C$?
- What is the velocity \vec{v}_P of point P ?
- What is the acceleration \vec{a}_P of point P ?

13.65 A uniform disc of radius $r = 200$ mm is mounted eccentrically on a motor shaft at point O . The motor rotates the disc at a constant angular speed. At the instant shown, the velocity of the center of mass is $\vec{v}_G = -1.5 \text{ m/s} \hat{j}$.

- Find the angular velocity of the disc.
- Find the point with the highest linear speed on the disc. What is its velocity?

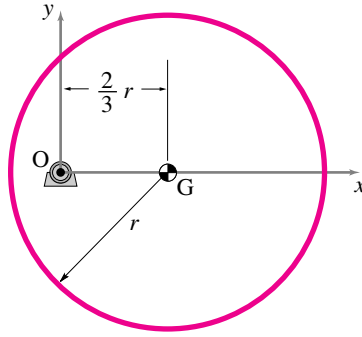

Filename:pfigure4-3-rp4

13.66 The circular disc of radius $R = 100$ mm rotates about its center O . At a given instant, point A on the disk has a velocity $v_A = 0.8 \text{ m/s}$ in the direction shown. At the same instant, the tangent of the angle θ made by the total acceleration vector of any point B with its radial line to O is 0.6 . Compute the angular acceleration α of the disc.

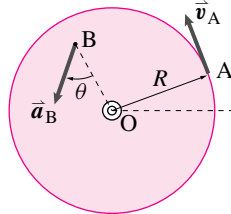

Filename:pfigure-blue-43-2

13.67 Show that, for non-constant rate circular motion, the acceleration of all points in a given radial line are parallel.

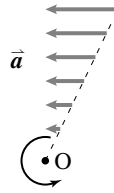

Filename:pfigure-DH-5-1a

13.68 A motor turns a uniform disc of radius R about its mass center at a variable angular rate ω with rate of change $\dot{\omega}$, counter-clockwise. The disc lies in the xy -plane and its angular displacement θ is measured from the x -axis, positive counter-clockwise. What are the velocity and acceleration of a point P at position

$\vec{r}_P = c\hat{i} + d\hat{j}$ relative to the velocity and acceleration of a point Q at position $\vec{r}_Q = 0.5(-d\hat{i} + y\hat{j})$ on the disk? ($c^2 + d^2 < R^2$.)

13.69 Bit-stream kinematics of a CD. A Compact Disk (CD) has bits of data etched on concentric circular tracks. The data from a track is read by a beam of light from a head that is positioned under the track. The angular speed of the disk remains constant as long as the head is positioned over a particular track. As the head moves to the next track, the angular speed of the disk changes, so that the *linear speed* at any track is always the same. The data stream comes out at a constant rate 4.32×10^6 bits/second. When the head is positioned on the outermost track, for which $r = 56$ mm, the disk rotates at 200 rpm.

- What is the number of bits of data on the outermost track.
- find the angular speed of the disk when the head is on the innermost track ($r = 22$ mm), and
- find the numbers of bits on the innermost track.

13.70 A horizontal disk \mathcal{D} of diameter $d = 500$ mm is driven at a constant speed of 100 rpm. A small disk \mathcal{C} can be positioned anywhere between $r = 10$ mm and $r = 240$ mm on disk \mathcal{D} by sliding it along the overhead shaft and then fixing it at the desired position with a set screw (see the figure). Disk \mathcal{C} rolls without slip on disk \mathcal{D} . The overhead shaft rotates with disk \mathcal{C} and, therefore, its rotational speed can be varied by varying the position of disk \mathcal{C} . This gear system is called *brush gearing*. Find the maximum and minimum rotational speeds of the overhead shaft.

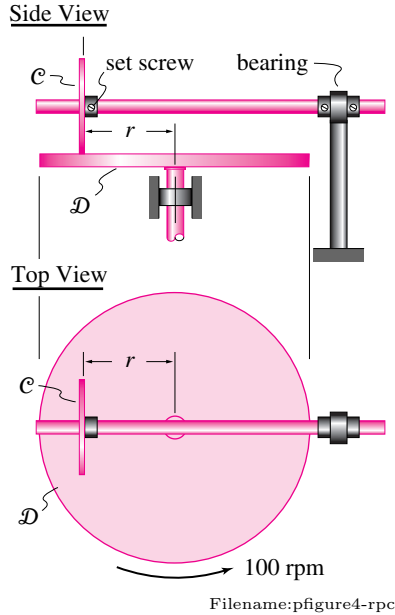

13.71 Two points A and B are on the same machine part that is hinged at an as yet unknown location C. Assume you are given that points at positions \vec{r}_A and \vec{r}_B are supposed to move in given directions, indicated by unit vectors as $\hat{\lambda}_A$ and $\hat{\lambda}_B$. For each of the parts below, illustrate your results with two numerical examples (in consistent units): i) $\vec{r}_A = 1\hat{i}$, $\vec{r}_B = 1\hat{j}$, $\hat{\lambda}_A = 1\hat{j}$, and $\hat{\lambda}_B = -1\hat{i}$ (thus $\vec{r}_C = \vec{0}$), and ii) a more complex example of your choosing.

- Describe in detail what equations must be satisfied by the point \vec{r}_C .
- Write a computer program that takes as input the 4 pairs of numbers $[\vec{r}_A]$, $[\vec{r}_B]$, $[\hat{\lambda}_A]$ and $[\hat{\lambda}_B]$ and gives as output the pair of numbers $[\hat{\lambda}_C]$.
- Find a formula of the form $\vec{r}_C = \dots$ that explicitly gives the position vector for point C in terms of the 4 given vectors.

13.4 Polar moment of inertia

13.72 A point mass $m = 0.5 \text{ kg}$ is located at $x = 0.3 \text{ m}$ and $y = 0.4 \text{ m}$ in the xy -plane. Find the moment of

inertia of the mass about the z -axis.

13.73 A small ball of mass 0.2 kg is attached to a 1 m long inextensible string. The ball is to execute circular motion in the xy -plane with the string fully extended.

- What is value of I_{zz} of the ball about the center of rotation?
- How much must you shorten the string to reduce the moment of inertia of the ball by half?

13.74 Two identical point masses are attached to the two ends of a rigid massless bar of length ℓ (one mass at each end). Locate a point along the length of the bar about which the polar moment of inertia of the system is 20% more than that calculated about the mid point of the bar.

13.75 A dumbbell consists of a rigid massless bar of length ℓ and two identical point masses m and m , one at each end of the bar.

- About which point on the dumbbell is its polar moment of inertia I_{zz} a minimum and what is this minimum value?
- About which point on the dumbbell is its polar moment of inertia I_{zz} a maximum and what is this maximum value?

13.76 Think first, calculate later. A light rigid rod AB of length 3ℓ has a point mass m at end A and a point mass $2m$ at end B . Point C is the center of mass of the system. First, answer the following questions without any calculations and then do calculations to verify your guesses.

- About which point A , B , or C , is the polar moment of inertia I_{zz} of the system a minimum?
- About which point is I_{zz} a maximum?

- What is the ratio of I_{zz}^A and I_{zz}^B ?
- Is the radius of gyration of the system greater, smaller, or equal to the length of the rod?

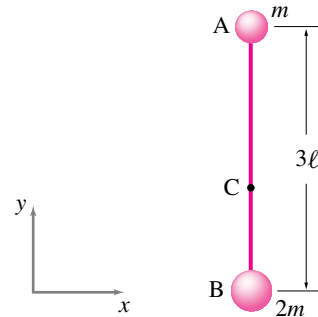

Filename:pfigure4-4-rp1

13.77 Do you understand the perpendicular axis theorem? Three identical particles of mass m are connected to three identical massless rods of length ℓ and welded together at point O as shown in the figure.

- Guess (no calculations) which of the three moment of inertia terms I_{xx}^O , I_{yy}^O , I_{zz}^O is the smallest and which is the biggest.
- Calculate the three moments of inertia to check your guess.
- If the orientation of the system is changed, so that one mass is along the x -axis, will your answer to part (a) change?
- Find the radius of gyration of the system for the polar moment of inertia.

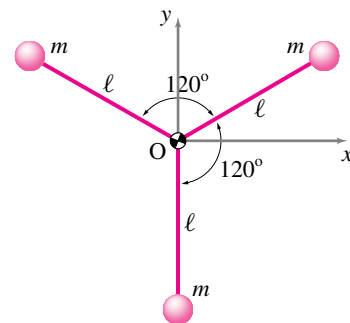

Filename:pfigure4-4-rp3

13.78 Show that the polar moment of inertia I_{zz}^O of the uniform bar of length ℓ and mass m , shown in the figure, is $\frac{1}{3}m\ell^2$, in two different ways:

- by using the basic definition of polar moment of inertia $I_{zz}^O = \int r^2 dm$, and
- by computing I_{zz}^{cm} first and then using the parallel axis theorem.

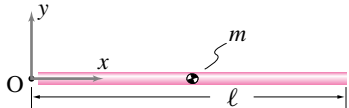

Filename:pfigure4-4-rp5

13.79 Locate the center of mass of the tapered rod shown in the figure and compute the polar moment of inertia I_{zz}^{cm} . [Hint: use the variable thickness of the rod to define a variable mass density per unit length.]

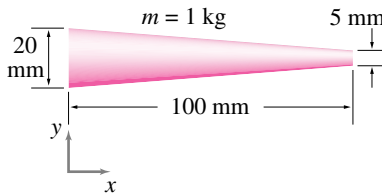

Filename:pfigure4-4-rp6

13.80 A short rod of mass m and length h hangs from an inextensible string of length ℓ .

- Find the moment of inertia I_{zz}^O of the rod.
- Find the moment of inertia of the rod I_{zz}^O by considering it as a point mass located at its center of mass.
- Find the percent error in I_{zz}^O in treating the bar as a point mass by comparing the expressions in parts (a) and (b). Plot the percent error versus h/ℓ . For what values of h/ℓ is the percentage error less than 5%?

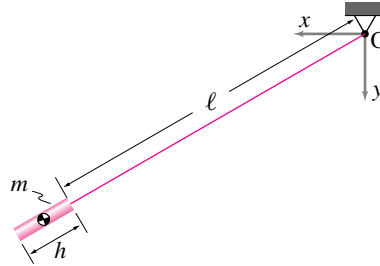

Filename:pfigure4-4-rp11

13.81 A small particle of mass m is attached to the end of a thin rod of mass M (uniformly distributed), which is pinned at hinge O , as depicted in the figure.

- Obtain the equation of motion governing the rotation θ of the rod.
- What is the natural frequency of the system for small oscillations θ ?

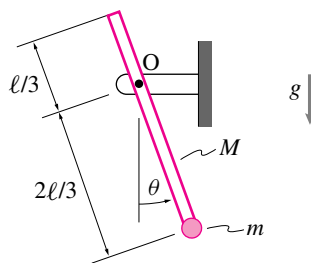

Filename:pfigure-blue-151-3

13.82 A thin rod of mass m and length ℓ is hinged with a torsional spring of stiffness K at A , and is connected to a thin disk of mass M and radius R at B . The spring is uncoiled when $\theta = 0$. Determine the natural frequency ω_n of the system for small oscillations θ , assuming that the disk is:

- welded to the rod, and
- pinned frictionlessly to the rod.

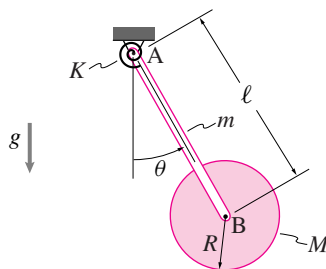

Filename:pfigure-blue-151-4

13.83 Do you understand the parallel axis theorem? A massless square plate $ABCD$ has four identical point masses located at its corners.

- Find the polar moment of inertia I_{zz}^{cm} .
- Find a point P on the plate about which the system's moment of inertia I_{zz} is maximum?
- Find the radius of gyration of the system.

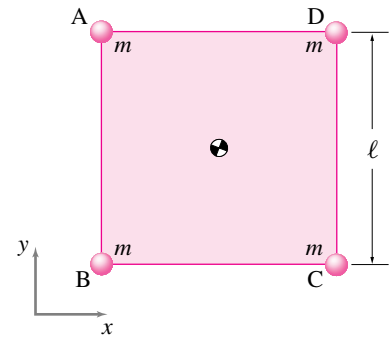

Filename:pfigure4-4-rp2

13.84 Perpendicular axis theorem and symmetry. For the massless square plate with four point masses on the corners, the polar moment of inertia $I_{zz}^{cm} = 0.6\text{kg} \cdot \text{m}^2$. Find I_{xx}^{cm} of the system.

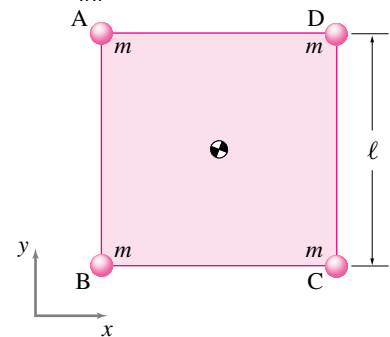

Filename:pfigure4-4-rp4

13.85 A uniform square plate (2 m on edge) has a corner cut out. The total mass of the remaining plate is 3 kg. It spins about the origin at a constant rate of one revolution every π s.

- What is the moment of inertia of the plate about point O ?
- Where is the center of mass of the plate at the instant shown?

- c) What are the velocity and acceleration of the center of mass at the instant shown?
- d) What is the angular momentum of the plate about the point O at the instant shown?
- e) What are the total force and moment required to maintain this motion when the plate is in the configuration shown?
- f) What is the total kinetic energy of the plate?

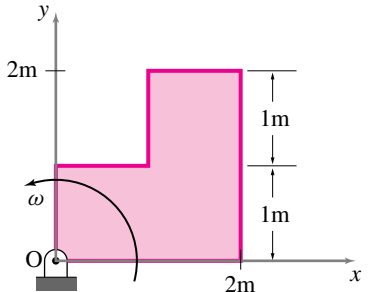

Filename:pfigure-blue-87b-1

13.86 A uniform thin triangular plate of mass m , height h , and base b lies in the xy -plane.

- a) Set up the integral to find the polar moment of inertia I_{zz}^O of the plate.
- b) Show that $I_{zz}^O = \frac{m}{6}(h^2 + 3b^2)$ by evaluating the integral in part (a).
- c) Locate the center of mass of the plate and calculate I_{zz}^{cm} .

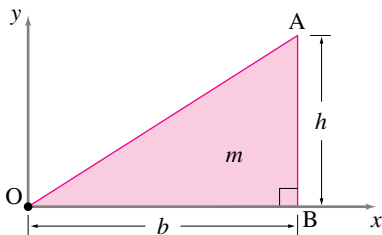

Filename:pfigure4-4-rp9

13.87 A uniform thin plate of mass m is cast in the shape of a semi-circular disk of radius R as shown in the figure.

- a) Find the location of the center of mass of the plate

- b) Find the polar moment of inertia of the plate, I_{zz}^{cm} . [Hint: It may be easier to set up and evaluate the integral for I_{zz}^O and then use the parallel axis theorem to calculate I_{zz}^{cm} .]

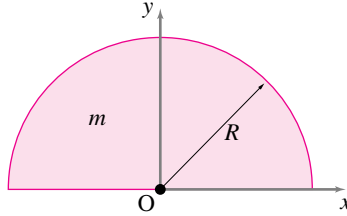

Filename:pfigure4-4-rp10

13.88 A uniform square plate of side $\ell = 250$ mm has a circular cut-out of radius $r = 50$ mm. The mass of the plate is $m = \frac{1}{2}$ kg.

- a) Find the polar moment of inertia of the plate.
- b) Plot I_{zz}^{cm} versus r/ℓ .
- c) Find the limiting values of I_{zz}^{cm} for $r = 0$ and $r = \ell$.

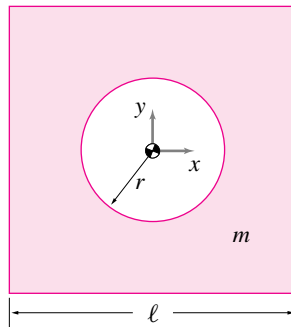

Filename:pfigure4-4-rp7

13.89 A uniform thin circular disk of radius $r = 100$ mm and mass $m = 2$ kg has a rectangular slot of width $w = 10$ mm cut into it as shown in the figure.

- a) Find the polar moment of inertia I_{zz}^O of the disk.
- b) Locate the center of mass of the disk and calculate I_{zz}^{cm} .

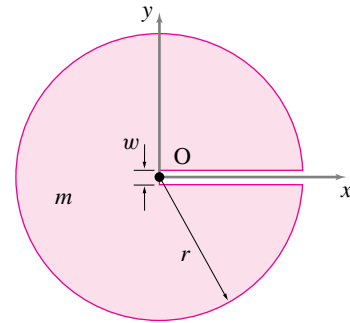

Filename:pfigure4-4-rp8

13.5 Dynamics of rigid-object planar circular motion

13.90 The structure shown in the figure consists of two point masses connected by three rigid, massless rods such that the whole structure behaves like a rigid body. The structure rotates counterclockwise at a constant rate of 60 rpm. At the instant shown, find the force in each rod.

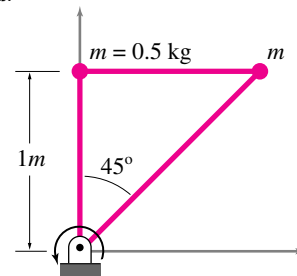

Filename:pfig4-1-rp10

13.91 The hinged disk of mass m (uniformly distributed) is acted upon by a force P shown in the figure. Determine the *initial* angular acceleration and the reaction forces at the pin O .

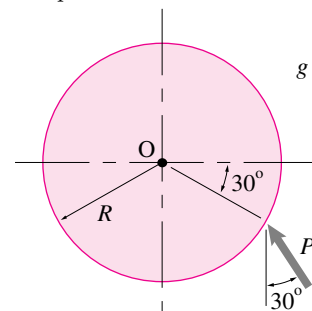

Filename:pfigure-blue-41-3

13.92 A thin uniform circular disc of mass M and radius R rotates in the xy plane about its center of mass point O . Driven by a motor, it has rate of change of angular speed proportional to angular position, $\alpha = d\theta^{5/2}$. The disc starts from rest at $\theta = 0$.

- What is the rate of change of angular momentum about the origin at $\theta = \frac{\pi}{3}$ rad?
- What is the torque of the motor at $\theta = \frac{\pi}{3}$ rad?
- What is the total kinetic energy of the disk at $\theta = \frac{\pi}{3}$ rad?

13.93 A uniform circular disc rotates at constant angular speed ω about the origin, which is also the center of the disc. It's radius is R . It's total mass is M .

- What is the total force and moment required to hold it in place (use the origin as the reference point of angular momentum and torque).
- What is the total kinetic energy of the disk?

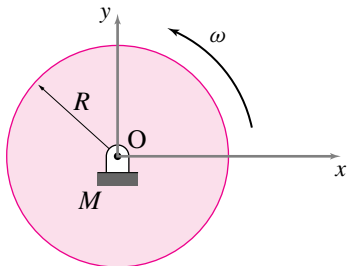

Filename:pfigure-blue-87a-1

13.94 Neglecting gravity, calculate $\alpha = \dot{\omega} = \ddot{\theta}$ at the instant shown for the system in the figure.

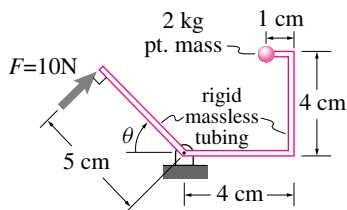

Filename:pfigure-blue-20-1

13.95 Slippery money A round uniform flat horizontal platform with radius R and mass m is mounted on frictionless bearings with a vertical axis at O . At the moment of interest it is rotating counter clockwise (looking down) with angular velocity $\vec{\omega} = \omega \hat{k}$. A force in the xy plane with magnitude F is applied at the perimeter at an angle of 30° from the radial direction. The force is applied at a location that is ϕ from the fixed positive x axis. At the moment of interest a small coin sits on a radial line that is an angle θ from the fixed positive x axis (with mass much much smaller than m). Gravity presses it down, the platform holds it up, and friction (coefficient= μ) keeps it from sliding.

Find the biggest value of d for which the coin does not slide in terms of some or all of $F, m, g, R, \omega, \theta, \phi$, and μ .

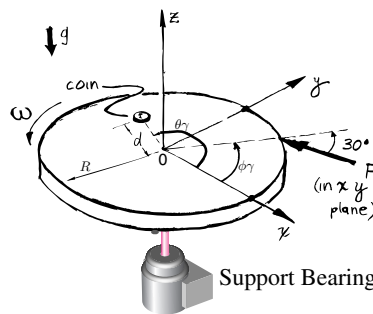

Filename:pfigure-slippermoney

13.96 A disk of mass M and radius R is attached to an electric motor as shown. A coin of mass m rests on the disk, with the center of the coin a distance r from the center of the disk. Assume that $m \ll M$, and that the coefficient of friction between the coin and the disk is μ . The motor delivers a constant power P to the disk. The disk starts from rest when the motor is turned on at $t = 0$.

- What is the angular velocity of the disk as a function of time?
- What is its angular acceleration?
- At what time does the coin begin to slip off the disk? (It will suffice here to give the equation for t that must be solved.)

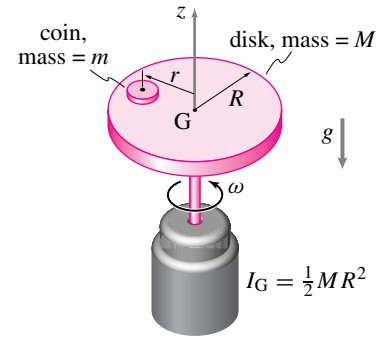

Filename:pfigure-blue-45-1

13.97 2-D constant rate gear train. The angular velocity of the input shaft (driven by a motor not shown) is a constant, $\omega_{\text{input}} = \omega_A$. What is the angular velocity $\omega_{\text{output}} = \omega_C$ of the output shaft and the speed of a point on the outer edge of disc C , in terms of R_A, R_B, R_C , and ω_A ?

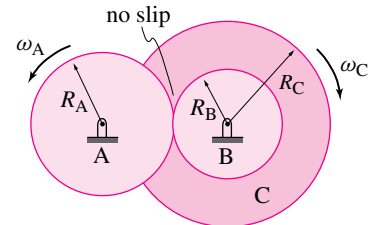

set of gears turning at constant rate.

Filename:ch4-3

13.98 2-D constant speed gear train. Gear A is connected to a motor (not shown) and gear B, which is welded to gear C, is connected to a taffy-pulling mechanism. Assume you know the torque $M_{\text{input}} = M_A$ and angular velocity $\omega_{\text{input}} = \omega_A$ of the input shaft. Assume the bearings and contacts are frictionless.

- What is the input power?
- What is the output power?
- What is the output torque $M_{\text{output}} = M_C$, the torque that gear C applies to its surroundings in the clockwise direction?

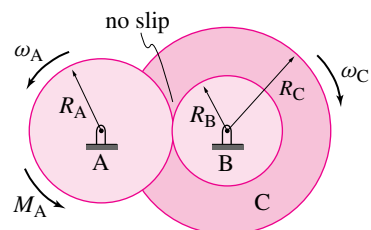

Filename:pfigure-s94h6p5

13.99 Accelerating rack and pinion. The two gears shown are welded together and spin on a frictionless bearing. The inner gear has radius 0.5 m and negligible mass. The outer disk has 1 m radius and a uniformly distributed mass of 0.2 kg. They are loaded as shown with the force $F = 20\text{ N}$ on the massless rack which is held in place by massless frictionless rollers. At the time of interest the angular velocity is $\omega = 2\text{ rad/s}$ (though ω is not constant). The point P is on the disk a distance 1 m from the center. At the time of interest, point P is on the positive y axis.

- What is the speed of point P?
- What is the velocity of point P?
- What is the angular acceleration α of the gear?
- What is the acceleration of point P?
- What is the magnitude of the acceleration of point P?
- What is the rate of increase of the speed of point P?

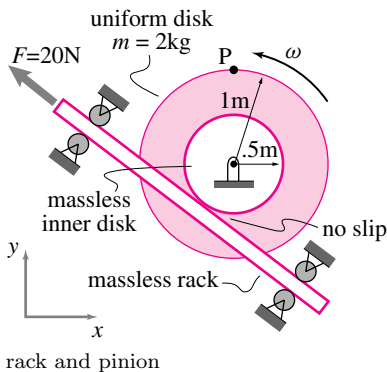

Filename:pg45-2

13.100 A 2-D constant speed gear train. Shaft B is rigidly connected to gears G_4 and G_3 . G_3 meshes with gear G_6 . Gears G_6 and G_5 are both rigidly attached to shaft CD. Gear G_5 meshes with G_2 which is welded to shaft A. Shaft A and shaft B spin independently. The input torque $M_{\text{input}} = 500\text{ N}\cdot\text{m}$ and the spin rate $\omega_{\text{input}} = 150\text{ rev/min}$. Assume the bearings and contacts are frictionless.

- What is the input power?
- What is the output power?

- What is the angular velocity ω_{output} of the output shaft?
- What is the output torque M_{output} ?

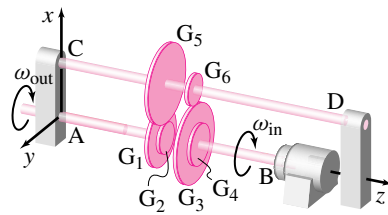

Front view

$$R_{G_5} = 3R_{G_2}$$

$$3R_{G_3} = 5R_{G_6}$$

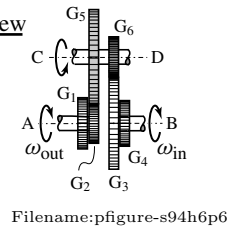

Filename:pfigure-s94h6p6

13.101 Two gears rotating at constant rate. At the input to a gear box a 100 lbf force is applied to gear A. At the output, the machinery (not shown) applies a force of F_B to the output gear. Gear A rotates at constant angular rate $\omega = 2\text{ rad/s}$, clockwise.

- What is the angular speed of the right gear?
- What is the velocity of point P?
- What is F_B ?
- If the gear bearings had friction, would F_B have to be larger or smaller in order to achieve the same constant velocity?
- If instead of applying a 100 lbf to the left gear it is driven by a motor (not shown) at constant angular speed ω , what is the angular speed of the right gear?

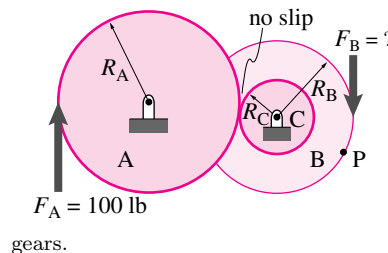

gears.

Filename:pg131-3

13.102 Two racks connected by a gear. A 100 lbf force is applied to one rack. At the output the machinery (not shown) applies a force F_B to the other rack.

- Assume the gear is spinning at constant rate and is frictionless. What is F_B ?
- If the gear bearing had friction, would that increase or decrease F_B to achieve the same constant rate?

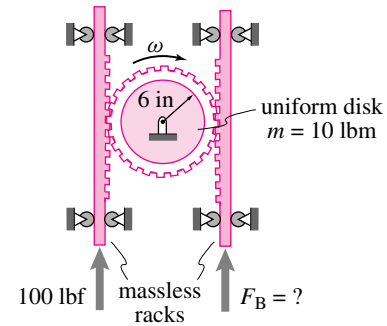

racks connected by a gear.

Filename:ch4-4

13.103 Constant rate rack and pinion. The two gears shown are welded together and spin on a frictionless bearing. The inner gear has radius 0.5 m and negligible mass. The outer gear has 1 m radius and a uniformly distributed mass of 0.2 kg. A motor (not shown) rotates the disks at constant rate $\omega = 2\text{ rad/s}$. The gears drive the massless rack which is held in place by massless frictionless rollers as shown. The gears and the rack have teeth that are not shown in the figure. The point P is on the outer gear a distance 1.0 m from the center. At the time of interest, point P is on the positive y axis.

- What is the speed of point P?
- What is the velocity of point P?
- What is the acceleration of point P?
- What is the velocity of the rack \vec{v}_r ?
- What is the force on the rack due to its contact with the inner gear?

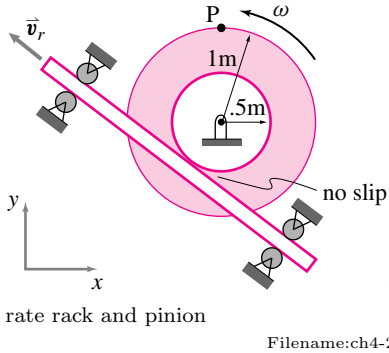

13.104 Belt drives are used to transmit power between parallel shafts. Two parallel shafts, 3 m apart, are connected by a belt passing over the pulleys *A* and *B* fixed to the two shafts. The driver pulley *A* rotates at a constant 200 rpm. The speed ratio between the pulleys *A* and *B* is 1:2.5. The input torque is 350 N·m. Assume no loss of power between the two shafts.

- Find the input power.
- Find the rotational speed of the driven pulley *B*.
- Find the output torque at *B*.

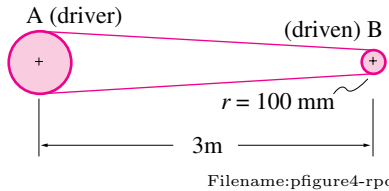

13.105 In the belt drive system shown, assume that the driver pulley rotates at a constant angular speed ω . If the motor applies a constant torque M_O on the driver pulley, show that the tensions in the two parts, *AB* and *CD*, of the belt must be different. Which part has a greater tension? Does your conclusion about unequal tension depend on whether the pulley is massless or not? Assume any dimensions you need.

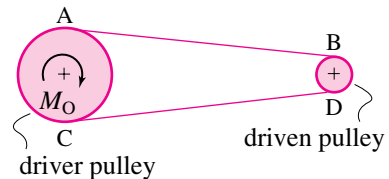

13.106 A belt drive is required to transmit 15 kW power from a 750 mm diameter pulley rotating at a constant 300 rpm to a 500 mm diameter pulley. The centers of the pulleys are located 2.5 m apart. The coefficient of friction between the belt and pulleys is $\mu = 0.2$.

- (See problem 13.127.) Draw a neat diagram of the pulleys and the belt-drive system and find the *angle of lap*, the contact angle θ , of the belt on the driver pulley.
- Find the rotational speed of the driven pulley.
- (See the figure in problem 13.127.) The power transmitted by the belt is given by *power* = *net tension* \times *belt speed*, i.e., $P = (T_1 - T_2)v$, where v is the linear speed of the belt. Find the maximum tension in the belt. [Hint: $\frac{T_1}{T_2} = e^{\mu\theta}$ (see problem 13.127).]
- The belt in use has a 15 mm \times 5 mm rectangular cross-section. Find the maximum tensile stress in the belt.

13.107 A bevel-type gear system, shown in the figure, is used to transmit power between two shafts that are perpendicular to each other. The driving gear has a mean radius of 50 mm and rotates at a constant speed $\omega = 150$ rpm. The mean radius of the driven gear is 80 mm and the driven shaft is expected to deliver a torque of $M_{out} = 25$ N·m. Assuming no power loss, find the input torque supplied by the driving shaft

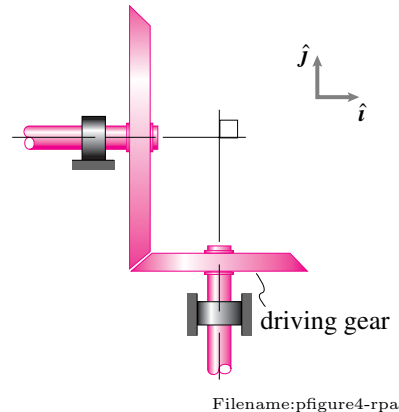

13.108 Disk pulleys. Two uniform disks *A* and *B* of *non-negligible* masses 10 kg and 5 kg respectively, are used as pulleys to hoist a block of mass 20 kg as shown in the figure. The block is pulled up by applying a force $F = 310$ N at one end of the string. Assume the string to be massless but ‘frictional’ enough to not slide on the pulleys. Use $g = 10$ m/s².

- Find the angular acceleration of pulley *B*.
- Find the acceleration of block *C*.
- Find the tension in the part of the string between the block and the overhead pulley.

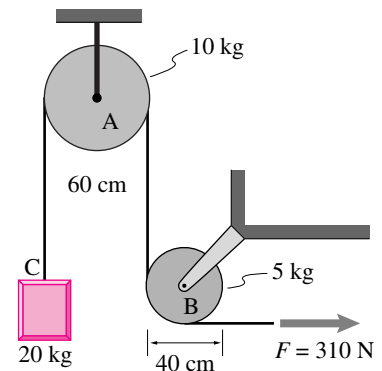

13.109 A pulley with mass *M* made of a uniform disk with radius *R* is mis-manufactured to have its hinge off of its center by a distance *h* (shown exaggerated in the figure). The system is released from rest in the position shown.

- Given α find the accelerations of the two blocks in terms of α and the dimensions shown.
- Find α .

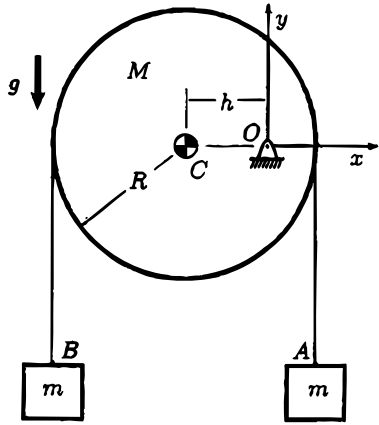

Filename:pfigure-crookedpulley

13.110 A spindle and pulley arrangement is used to hoist a 50 kg mass as shown in the figure. Assume that the pulley is to be of negligible mass. When the motor is running at a constant 100 rpm,

- Find the velocity of the mass at B.
- Find the tension in strings AB and CD.

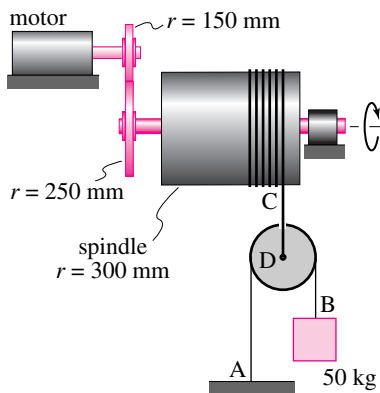

Filename:pfigure4-rpg

13.111 Two racks connected by three constant rate gears. A 100 lbf force is applied to one rack. At the output, the machinery (not shown) applies a force of F_B to the other rack.

- Assume the gear-train is spinning at constant rate and is frictionless. What is F_B ?
- If the gear bearings had friction would that increase or decrease F_B to achieve the same constant rate?

c) If instead of applying a 100 lbf to the left rack it is driven by a motor (not shown) at constant speed v , what is the speed of the right rack?

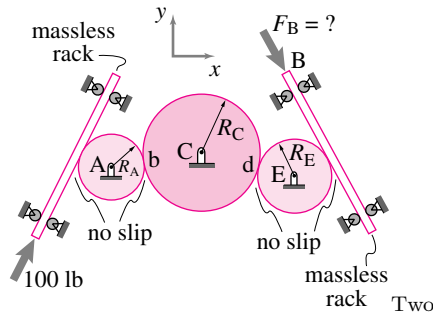

racks connected by three gears.

Filename:ch4-5

13.112 Two racks connected by three accelerating gears. A 100 lbf force is applied to one rack. At the output, the machinery (not shown) applies a force of F_B to the other rack.

- Assume the gear-train is spinning at constant rate and is frictionless, what is F_B ?
- If the gear bearings had friction would that increase or decrease F_B to achieve the same constant rate?
- If the angular velocity of the gear is increasing at rate α does this increase or decrease F_B at the given ω .

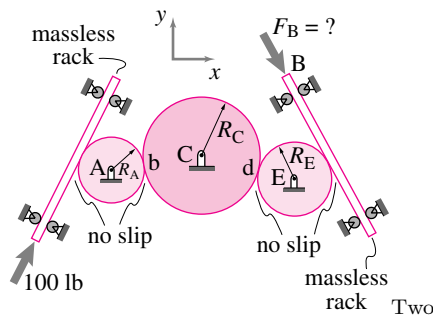

racks connected by three gears.

Filename:pg131-2

13.113 -3-D accelerating gear train. This is really a 2-D problem; each gear turns in a different parallel plane. Shaft B is rigidly connected to gears G_4 and G_5 . G_3 meshes with gear G_6 . Gears G_6 and G_5 are both

rigidly attached to shaft AD. Gear G_5 meshes with G_2 which is welded to shaft A. Shaft A and shaft B spin independently. Assume you know the torque M_{input} , angular velocity ω_{input} and the angular acceleration α_{input} of the input shaft. Assume the bearings and contacts are frictionless.

- What is the input power?
- What is the output power?
- What is the angular velocity ω_{output} of the output shaft?
- What is the output torque M_{output} ?

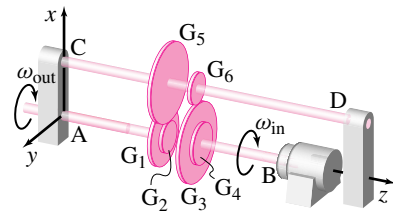

Front view

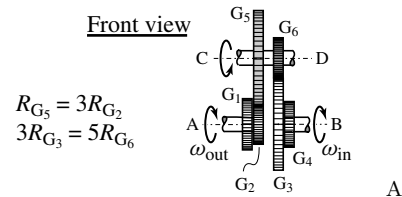

3-D set of gears turning at constant rate.

Filename:3dgeartrain

13.114 A uniform disk of mass M and radius R rotates about a hinge O in the xy -plane. A point mass m is fixed to the disk at a distance $R/2$ from the hinge. A motor at the hinge drives the disk/point mass assembly with constant angular acceleration α . What torque at the hinge does the motor supply to the system?

13.115 The asymmetric dumbbell shown in the figure is pivoted in the center and also attached to a spring at one quarter of its length from the bigger mass. When the bar is horizontal, the compression in the spring is y_s . At the instant of interest, the bar is at an angle θ from the horizontal; θ is small enough so that $y \approx \frac{L}{2}\theta$. If, at this position, the velocity of mass ' m ' is $v\hat{j}$ and that of mass $3m$ is $-v\hat{j}$, evaluate the power

term $(\sum \vec{F} \cdot \vec{v})$ in the energy balance equation.

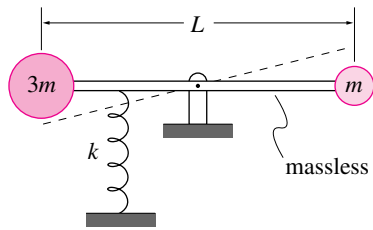

Filename:pfig2-3-rp4

13.116 The dumbbell shown in the figure has a torsional spring with spring constant k (torsional stiffness units are $\frac{\text{kN}\cdot\text{m}}{\text{rad}}$). The dumbbell oscillates about the horizontal position with small amplitude θ . At an instant when the angular velocity of the bar is $\dot{\theta}\hat{k}$, the velocity of the left mass is $-L\dot{\theta}\hat{j}$ and that of the right mass is $L\dot{\theta}\hat{j}$. Find the expression for the power P of the spring on the dumbbell at the instant of interest.

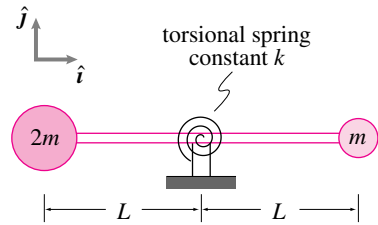

Filename:pfig2-3-rp10

13.117 A physical pendulum. A swinging stick is sometimes called a ‘physical’ pendulum. Take the ‘body’, the system of interest, to be the whole stick.

- Draw a free body diagram of the system.
- Write the equation of angular momentum balance for this system about point O .
- Evaluate the left-hand-side as explicitly as possible in terms of the forces showing on your Free Body Diagram.
- Evaluate the right hand side as completely as possible. You may use the following facts:

$$\begin{aligned} \vec{v} &= l\dot{\theta}\cos\theta\hat{j} - l\dot{\theta}\sin\theta\hat{i} \\ \vec{a} &= -l\dot{\theta}^2[\cos\theta\hat{i} + \sin\theta\hat{j}] \\ &\quad + l\ddot{\theta}[\cos\theta\hat{j} - \sin\theta\hat{i}] \end{aligned}$$

where l is the distance along the pendulum from the top, θ is the angle by which the pendulum is displaced counter-clockwise from the vertically down position, \hat{i} is vertically down, and \hat{j} is to the right. You will have to set up and evaluate an integral.

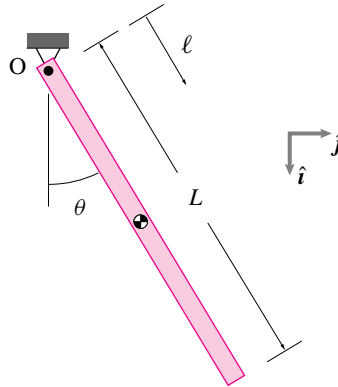

Filename:ppend

13.118 Which of (a), (b), and (c) are two force members?

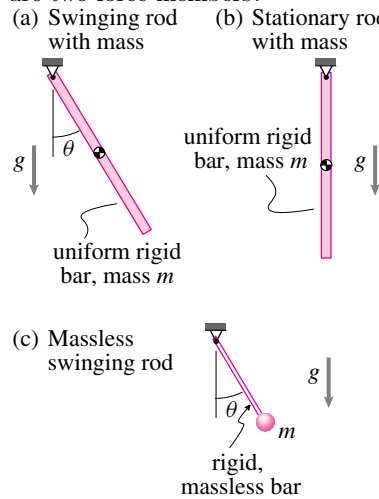

Filename:pfigure2-two-force

13.119 For the pendula in the figure :

- Without doing any calculations, try to figure out the relative durations of the periods of oscillation for the five pendula (i.e. the order, slowest to fastest) Assume small angles of oscillation.

- Calculate the period of small oscillations. [Hint: use balance of angular momentum about the point O].
- Rank the relative duration of oscillations and compare to your intuitive solution in part (a), and explain in words why things work the way they do.

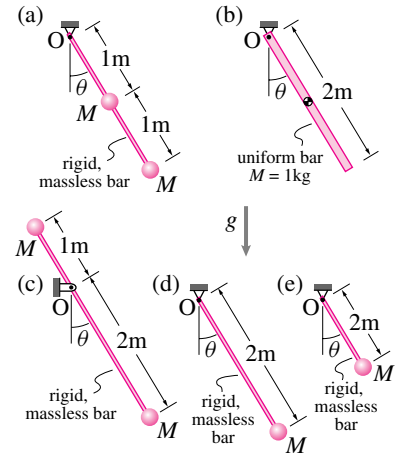

Filename:pg144-1n

13.120 A massless 10 meter long bar is supported by a frictionless hinge at one end and has a 3.759 kg point mass at the other end. It is released at $t = 0$ from a tip angle of $\phi = .02$ radians measured from vertically upright position (hinge at the bottom). Use $g = 10\text{m/s}^2$.

- Using a small angle approximation and the solution to the resulting linear differential equation, find the angle of tip at $t = 1\text{s}$ and $t = 7\text{s}$. Use a calculator, not a numerical integrator.
- Using numerical integration of the non-linear differential equation for an inverted pendulum find ϕ at $t = 1\text{s}$ and $t = 7\text{s}$.
- Make a plot of the angle versus time for your numerical solution. Include on the same plot the angle versus time from the approximate linear solution from part (a).
- Comment on the similarities and differences in your plots.

13.121 A spring-mass-damper system is depicted in the figure. The horizontal damping force applied at B is given by $F_D = -c \dot{y}_B$. The dimensions and parameters are as follows:

$$\begin{aligned} r_{B/0} &= 2ft \\ r_{A/0} &= \ell = 3ft \\ k &= 2\text{ lbf/ft} \\ c &= 0.3\text{ lbf} \cdot \text{s/ft} \end{aligned}$$

For small θ , assume that $\sin(\theta) \approx \theta$ and $\cos(\theta) \approx 1$.

- Determine the natural circular frequency of small oscillations about equilibrium for the pendulum shown. The static equilibrium position is $\theta = 0$ (pendulum hanging vertically), so the spring is at its rest point in this position. Idealize the pendulum as a point mass attached to a rigid massless rod of length ℓ , so $I^O = m\ell^2$. Also use the “small angle approximation” where appropriate.
- Sketch a graph of θ as a function of t ($t \geq 0$) if the pendulum is released from rest at position $\theta = 0.2\text{ rad}$ when $t = 0$. Your graph should show the correct qualitative behavior, but calculations are not necessary.

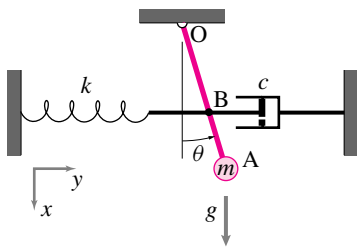

Filename: pfigure-blue-157-2

13.122 A rigid massless rod has two equal masses m_B and m_C ($m_B = m_C = m$) attached to it at distances 2ℓ and 3ℓ , respectively, measured along the rod from a frictionless hinge located at a point A. The rod swings freely from the hinge. There is gravity. Let ϕ denote the angle of the rod measured from the vertical. Assume that ϕ and $\dot{\phi}$ are known at the moment of interest.

- What is $\ddot{\phi}$? Solve in terms of m , ℓ , g , ϕ and $\dot{\phi}$.

- What is the force of the hinge on the rod? Solve in terms of m , ℓ , g , ϕ , $\dot{\phi}$, $\ddot{\phi}$ and any unit vectors you may need to define.
- Would you get the same answers if you put a mass $2m$ at 2.5ℓ ? Why or why not?

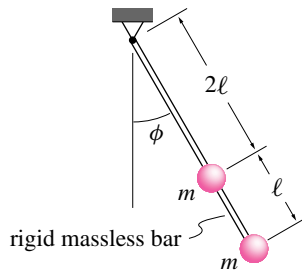

Filename: pfigure-twomasspend

13.123 A zero length spring (relaxed length $\ell_0 = 0$) with stiffness $k = 5\text{ N/m}$ supports the pendulum shown.

- Find $\ddot{\theta}$ assuming $\dot{\theta} = 2\text{ rad/s}$, $\theta = \pi/2$.
- Find $\ddot{\theta}$ as a function of $\dot{\theta}$ and θ (and k , ℓ , m , and g).

[Hint: use vectors (otherwise it's hard)]

[Hint: For the special case, $kD = mg$, the solution simplifies greatly.]

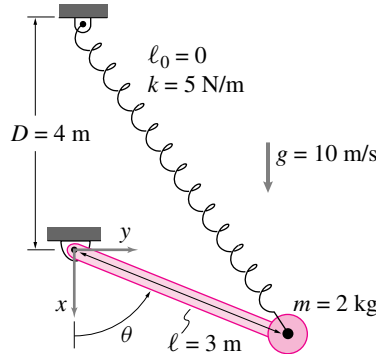

Filename: pfigure-blue-80-2

13.124 Robotics problem: Simplest balancing of an inverted pendulum. You are holding a stick upside down, one end is in your hand, the other end sticking up. To simplify things, think of the stick as massless but with a point mass at the upper end. Also, imagine that it is only a two-dimensional problem (either you can ignore one direction of

falling for simplicity or imagine wire guides that keep the stick from moving in and out of the plane of the paper on which you draw the problem).

You note that if you model your holding the stick as just having a stationary hinge then you get $\dot{\phi} = \frac{g}{\ell} \sin \phi$. Assuming small angles, this hinge leads to exponentially growing solutions. Upside-down sticks fall over. How can you prevent this falling?

One way to do keep the stick from falling over is to firmly grab it with your hand, and if the stick tips, apply a torque in order to right it. This corrective torque is (roughly) how your ankles keep you balanced when you stand upright. Your task in this assignment is to design a robot that keeps an inverted pendulum balanced by applying appropriate torque.

Your model is: Inverted pendulum, length ℓ , point mass m , and a hinge at the bottom with a motor that can apply a torque T_m . The stick might be tipped an angle ϕ from the vertical. A horizontal disturbing force $F(t)$ is applied to the mass (representing wind, annoying friends, etc).

- Draw a picture and a FBD
- Write the equation for angular momentum balance about the hinge point.
- Imagine that your robot can sense the angle of tip ϕ and its rate of change $\dot{\phi}$ and can apply a torque in response to that sensing. That is you can make T_m any function of ϕ and $\dot{\phi}$ that you want. Can you find a function that will make the pendulum stay upright? Make a guess (you will test it below).
- Test your guess the following way: plug it into the equation of motion from part (b), linearize the equation, assume the disturbing force is zero, and see if the solution of the differential equation has exponentially growing (i.e. unstable) solutions. Go back to (c) if it does and find a control strategy that works.
- Pick numbers and model your system on a computer using the full non-linear equations. Use initial conditions

both close to and far from the upright position and plot ϕ versus time.

- f) If you are ambitious, pick a non-zero forcing function $F(t)$ (say a sine wave of some frequency and amplitude) and see how that affects the stability of the solution in your simulations.

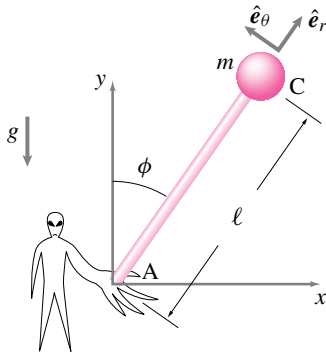

Filename:pfigure-s94h9p1

13.125 Balancing a system of rotating particles. A wire frame structure is made of four concentric loops of massless and rigid wires, connected to each other by four rigid wires presently coincident with the x and y axes. Three masses, $m_1 = 200$ grams, $m_2 = 150$ grams and $m_3 = 100$ grams, are glued to the structure as shown in the figure. The structure rotates counter-clockwise at a constant rate $\dot{\theta} = 5$ rad/s. There is no gravity.

- Find the net force exerted by the structure on the support at the instant shown.
- You are to put a mass m at an appropriate location on the third loop so that the net force on the support is zero. Find the appropriate mass and the location on the loop.

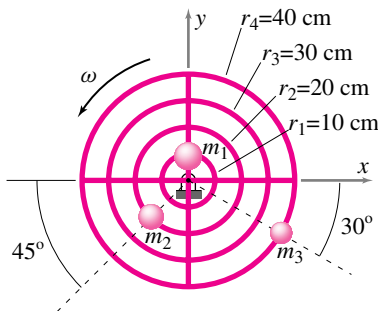

Filename:pfigure-s94h6p2

13.126 A rope of length ℓ and total mass m is held fixed at one end and whirled around in circular motion at a constant rate ω in the horizontal plane. Ignore gravity.

- Find the tension in the rope as a function of r , the radial distance from the center of rotation to any desired location on the rope.
- Where does the maximum tension occur in the rope?
- At what distance from the center of rotation does the tension drop to half its maximum value?

13.127 Assume that the pulley shown in figure(a) rotates at a constant speed ω . Let the angle of contact between the belt and pulley surface be θ . Assume that the belt is massless and that the condition of impending slip exists between the pulley and the belt. The free body diagram of an infinitesimal section ab of the belt is shown in figure(b).

- Write the equations of linear momentum balance for section ab of the belt in the \hat{i} and \hat{j} directions.
- Eliminate the normal force N from the two equations in part (a) and get a differential equation for the tension T in terms of the coefficient of friction μ and the contact angle θ .
- Show that the solution to the equation in part (b) satisfies $\frac{T_1}{T_2} = e^{\mu\theta}$, where T_1 and T_2 are the tensions in the lower and the upper segments of the belt, respectively.

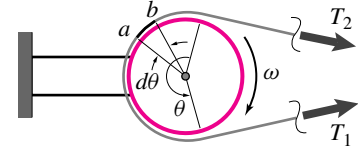

(a)

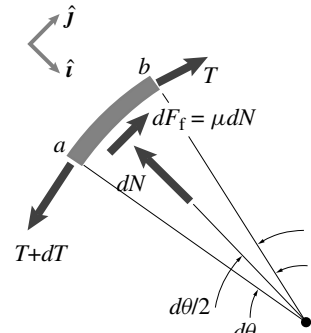

(b)

Filename:pfigure4-rpf

13.6 Using I_{zz}^{cm} and I_{zz}^O in mechanics equations

13.128 Motor turns a dumbbell. Two uniform bars of length ℓ and mass m are welded at right angles. At the ends of the horizontal bar are two more masses m . The bottom end of the vertical rod is attached to a hinge at O where a motor keeps the structure rotating at constant rate ω (counter-clockwise). What is the net force and moment that the motor and hinge cause on the structure at the instant shown?

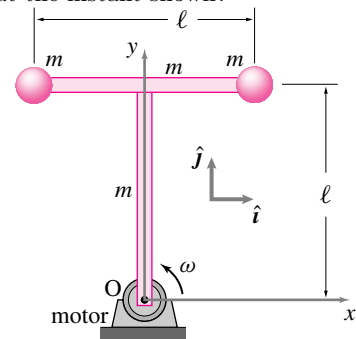

Filename:pfigure-s94h5p5

13.129 An object consists of a massless bar with two attached masses m_1 and m_2 . The object is hinged at O .

- What is the moment of inertia of the object about point O (I_{zz}^O)?
- Given θ , $\dot{\theta}$, and $\ddot{\theta}$, what is $\vec{H}_{/O}$, the angular momentum about point O ?
- Given θ , $\dot{\theta}$, and $\ddot{\theta}$, what is $\dot{\vec{H}}_{/O}$, the rate of change of angular momentum about point O ?
- Given θ , $\dot{\theta}$, and $\ddot{\theta}$, what is T , the total kinetic energy?
- Assume that you don't know θ , $\dot{\theta}$ or $\ddot{\theta}$ but you do know that F_1 is applied to the rod, perpendicular to the rod at m_1 . What is $\dot{\theta}$? (Neglect gravity.)
- If F_1 were applied to m_2 instead of m_1 , would $\dot{\theta}$ be bigger or smaller?

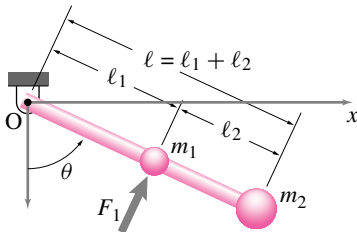

Filename:pfigure-blue-82-1

13.130 A uniform rigid rod rotates at constant speed in the xy -plane about a peg at point O . The center of mass of the rod may not exceed a specified acceleration $a_{max} = 0.5 \text{ m/s}^2$. Find the maximum angular velocity of the rod.

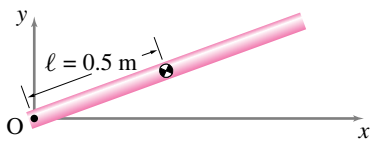

Filename:pfigure4-3-rp3

13.131 A uniform one meter bar is hung from a hinge that is at the end. It is allowed to swing freely. $g = 10 \text{ m/s}^2$.

- What is the period of small oscillations for this pendulum?
- Suppose the rod is hung 0.4 m from one end. What is the period of small oscillations for this pendulum? Can you explain why it is longer or shorter than when it is hung by its end?

13.132 A motor turns a bar. A uniform bar of length ℓ and mass m is turned by a motor whose shaft is attached to the end of the bar at O . The angle that the bar makes (measured counter-clockwise) from the positive x axis is $\theta = 2\pi t^2/s^2$. Neglect gravity.

- Draw a free body diagram of the bar.
- Find the force acting on the bar from the motor and hinge at $t = 1 \text{ s}$.
- Find the torque applied to the bar from the motor at $t = 1 \text{ s}$.
- What is the power produced by the motor at $t = 1 \text{ s}$?

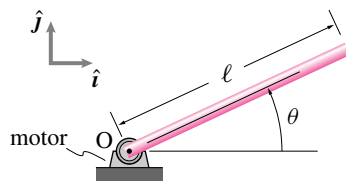

Filename:pfigure-f93f1

13.133 The rod shown is uniform with total mass m and length ℓ . The rod is pinned at point O . A linear spring with stiffness k is attached at the point A at height h above O and along the rod as shown. When $\theta = 0$, the spring is unstretched. Assume that θ is small for both parts of this problem.

- Find the natural frequency of vibration (in radians per second) in terms of m , g , h , ℓ and k .
- If you have done the calculation above correctly there is a value of h for which the natural frequency is zero. Call this value of h , h_{crit} . What is the behavior of the system when $h < h_{crit}$? (Desired is a phrase pointing out any qualitative change in the type of motion with some justification.)

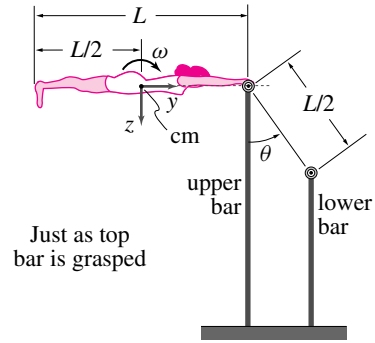

Just as top bar is grasped

Filename:pfigure-blue-130-2

13.134 A uniform stick of length ℓ and mass m is a hair away from vertically up position when it is released with no angular velocity (a 'hair' is a technical word that means 'very small amount, zero for some purposes'). It falls to the right. What is the force on the stick at point O when the stick is horizontal. Solve in terms of ℓ , m , g , \hat{i} , and \hat{j} . Carefully define any coordinates, base vectors, or angles that you use.

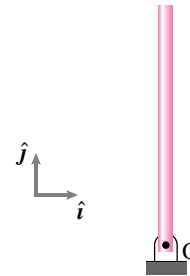

Filename:pfigure-s94q8p1

13.135 Acceleration of a trap door. A uniform bar AB of mass m and a ball of the same mass are released from rest from the same horizontal position. The bar is hinged at end A . There is gravity.

- Which point on the rod has the same acceleration as the ball, immediately after release.
- What is the reaction force on the bar at end A just after release?

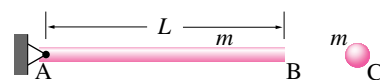

Filename:pfigure-s94h8p3

13.136 A pegged compound pendulum. A uniform bar of mass m and length ℓ hangs from a peg at point C and swings in the vertical plane about an axis passing through the peg. The distance d from the center of mass of the rod to the peg can be changed by putting the peg at some other point along the length of the rod.

- Find the angular momentum of the rod as about point C.
- Find the rate of change of angular momentum of the rod about C.
- How does the period of the pendulum vary with d ? Show the variation by plotting the period against $\frac{d}{\ell}$. [Hint, you must first find the equations of motion, linearize for small θ , and then solve.]
- Find the total energy of the rod (using the height of point C as a datum for potential energy).
- Find $\ddot{\theta}$ when $\theta = \pi/6$.
- Find the reaction force on the rod at C, as a function of m , d , ℓ , θ , and $\dot{\theta}$.
- For the given rod, what should be the value of d (in terms of ℓ) in order to have the fastest pendulum?

- Test of Schuler's pendulum.** The pendulum with the value of d obtained in (g) is called the Schuler's pendulum. It is not only the fastest pendulum but also the "most accurate pendulum". The claim is that even if d changes slightly over time due to wear at the support point, the period of the pendulum does not change much. Verify this claim by calculating the percent error in the time period of a pendulum of length $\ell = 1$ m under the following three conditions: (i) initial $d = 0.15$ m and after some wear $d = 0.16$ m, (ii) initial $d = 0.29$ m and after some wear $d = 0.30$ m, and (iii) initial $d = 0.45$ m and after some wear $d = 0.46$ m. Which pendulum shows the least error in its time period? Do you see any connection between this

result and the plot obtained in (c)?

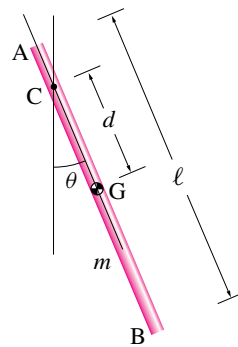

Filename:pfigure-s94h8p6

13.137 Given $\ddot{\theta}$, $\dot{\theta}$, and θ , what is the total kinetic energy of the pegged compound pendulum in problem 13.136?

13.138 A slender uniform bar AB of mass M is hinged at point O, so it can rotate around O without friction. Initially the bar is at rest in the vertical position as shown. A bullet of mass m and horizontal velocity V_0 strikes the end A of the bar and sticks to it (an inelastic collision). Calculate the angular velocity of the system — the bar with its embedded bullet, immediately after the impact.

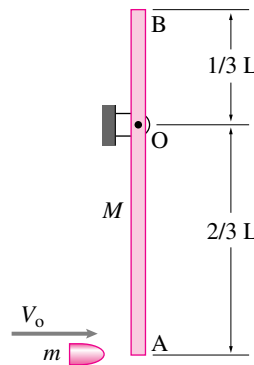

Filename:pfigure-blue-78-1

13.139 Motor turns a bent bar. Two uniform bars of length ℓ and uniform mass m are welded at right angles. One end is attached to a hinge at O where a motor keeps the structure rotating at a constant rate ω (counterclockwise). What is the net force and moment that the motor and hinge cause on the structure at the instant shown.

- neglecting gravity
- including gravity.

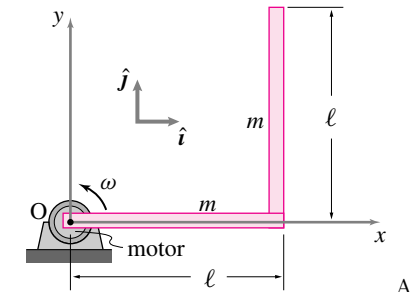

bent bar is rotated by a motor.

Filename:pg85-3

13.140 2-D problem, no gravity. A uniform stick with length ℓ and mass M_0 is welded to a pulley hinged at the center O. The pulley has negligible mass and radius R_p . A string is wrapped many times around the pulley. At time $t = 0$, the pulley, stick, and string are at rest and a force F is suddenly applied to the string. How long does it take for the pulley to make one full revolution?

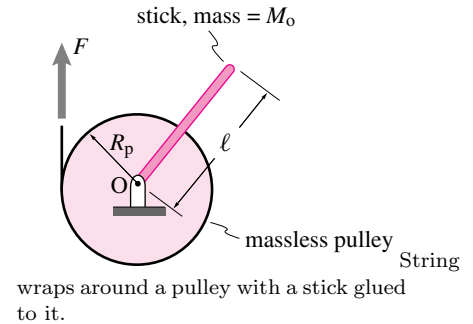

Filename:p2-3

13.141 A thin hoop of radius R and mass M is hung from a point on its edge and swings in its plane. Assuming it swings near to the position where its center of mass G is below the hinge:

- What is the period of its swinging oscillations?
- If, instead, the hoop was set to swinging in and out of the plane would the period of oscillations be greater or less?

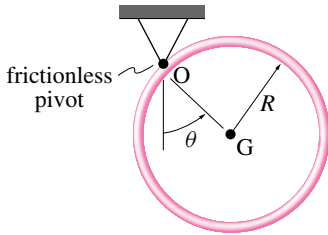

Filename:pfigure-blue-145-1

13.142 The uniform square shown is released from rest at $t = 0$. What is $\alpha = \dot{\omega} = \ddot{\theta}$ immediately after release?

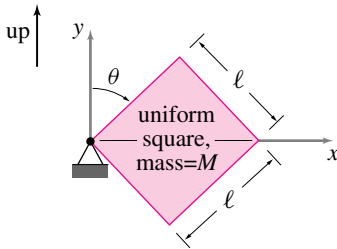

Filename:pfigure-blue-42-2

13.143 A square plate with side ℓ and mass m is hinged at one corner in a gravitational field g . Find the period of small oscillation.

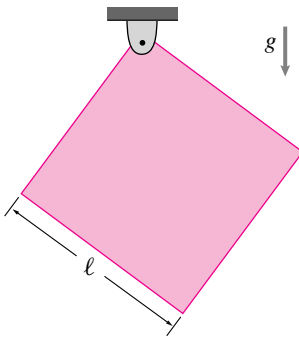

Filename:p-f96-p3-2

13.144 A wheel of radius R and moment of inertia I about the axis of rotation has a rope wound around it. The rope supports a weight W . Write the equation of conservation of energy for this system, and differentiate to find the equation of motion in terms of acceleration. Check the solution obtained by drawing separate free-body diagrams for the wheel and for the weight, writing the equations of motion for each body,

and solving the equations simultaneously. Assume that the mass of the rope is negligible, and that there is no energy loss during the motion.

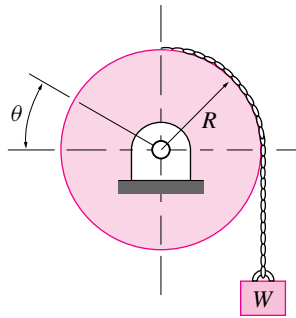

Filename:pfigure-blue-136-1

13.145 A disk with radius R has a string wrapped around it which is pulled with a force F . The disk is free to rotate about the axis through O normal to the page. The moment of inertia of the disk about O is I_o . A point A is marked on the string. Given that $x_A(0) = 0$ and that $\dot{x}_A(0) = 0$, what is $x_A(t)$?

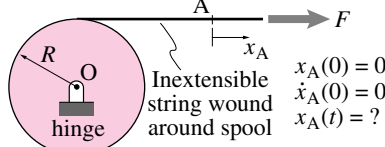

Spool has mass moment of inertia, I_O

Filename:pfigure-blue-42-1

13.146 Oscillating disk. A uniform disk with mass m and radius R pivots around a frictionless hinge at its center. It is attached to a massless spring which is horizontal and relaxed when the attachment point is directly above the center of the disk. Assume small rotations and the consequent geometrical simplifications. Assume the spring can carry compression. What is the period of oscillation of the disk if it is disturbed from its equilibrium configuration? [You may use the fact that, for the disk shown, $\vec{H}_{/O} = \frac{1}{2}mR^2\dot{\theta}\hat{k}$, where θ is the angle of rotation of the disk.]

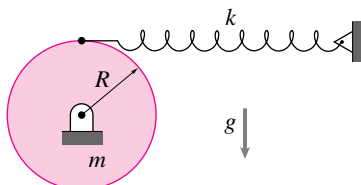

Filename:pg147-2

13.147 This problem concerns a narrow rigid hoop. For reference, here are dimensions and values you should use in this problem: mass of hoop $m_{\text{hoop}} = 1$ kg radius of hoop $R_{\text{hoop}} = 3$ m, and gravitational acceleration $g = 10$ m/s².

- The hoop is hung from a point on its edge and swings in its plane. Assuming its swings near to the position where its center of mass is below the hinge.
- What is the period of its swinging oscillations?
- If, instead, the hoop was set to swinging in and out of the plane would the period of oscillations be greater or less?

13.148 The compound pulley system shown in the figure consists of two pulleys rigidly connected to each other. The radii of the two pulleys are: $R_i = 0.2$ m and $R_o = 0.4$ m. The combined moment of inertia of the two pulleys about the axis of rotation is 2.7 kg·m². The two masses, $m_1 = 40$ kg and $m_2 = 100$ kg, are released from rest in the configuration shown. Just after release,

- find the angular acceleration of the pulleys, and
- find the tension in each string.

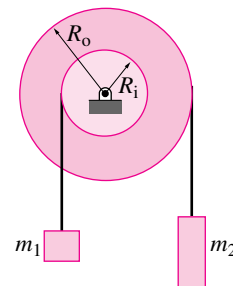

Filename:summer95p2-1

13.149 Consider a system of two blocks A and B and the reel C mounted at the fixed point O, as shown in the figure. Initially the system is at rest. Calculate the velocity for the block B after it has dropped a vertical distance h . Given: h , mass of block A, M_A , coefficient of friction

μ , slope angle θ , mass of the reel, M_C , moment of inertia I about the center of mass at O , radius of gyration of the reel K_C , outer radius of the reel R_C , inner radius of the reel $\frac{1}{2}R_C$, mass of the block B M_B .

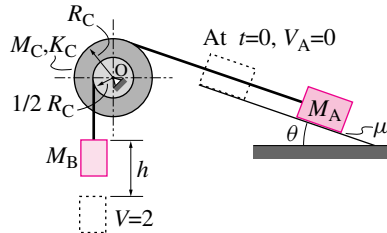

Filename:pfigure-blue-135-1

13.150 Gear A with radius $R_A = 400$ mm is rigidly connected to a drum B with radius $R_B = 200$ mm. The combined moment of inertia of the gear and the drum about the axis of rotation is $I_{zz} = 0.5 \text{ kg} \cdot \text{m}^2$. Gear A is driven by gear C which has radius $R_C = 300$ mm. As the drum rotates, a 5 kg mass m is pulled up by a string wrapped around the drum. At the instant of interest, The angular speed and angular acceleration of the driving gear are 60 rpm and 12 rpm/s, respectively. Find the acceleration of the mass m .

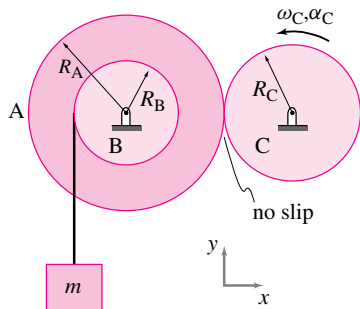

Filename:summer95f-2

13.151 Two gears accelerating. At the input to a gear box a 100 lbf force is applied to gear A. At the output the machinery (not shown) applies a force of F_B to the output gear.

- Assume the gear is spinning at constant rate and is frictionless, what is F_B ?
- If the gear bearing had friction would that increase or decrease F_B ?

c) If the angular velocity of the gear is increasing at rate α does this increase or decrease F_B at the given ω .

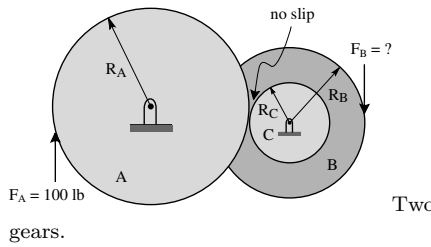

Filename:pg131-3-aa

13.152 Frequently parents will build a tower of blocks for their children. Just as frequently, kids knock them down. In falling (even when they start to topple aligned), these towers invariably break in two (or more) pieces at some point along their length. Why does this breaking occur? What condition is satisfied at the point of the break? Will the stack bend towards or away from the floor after the break?

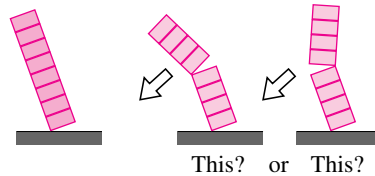

Filename:pfigure-blue-129-1

13.153 Massless pulley, dumbbell and a hanging mass. A mass m falls vertically but is withheld by a string which is wrapped around an ideal massless pulley with radius a . The pulley is welded to a dumbbell made of uniform solid spheres at A and B of radius R , each of whose center is a distance ℓ from O . At the instant in question, the dumbbell makes an angle θ with the positive x axis and is spinning at the rate $\dot{\theta}$. Point C is a distance h down from O . In terms of some or all of $m, M, a, R, \ell, h, g, \theta, \dot{\theta}$, and \hat{j} , find the acceleration of the mass.

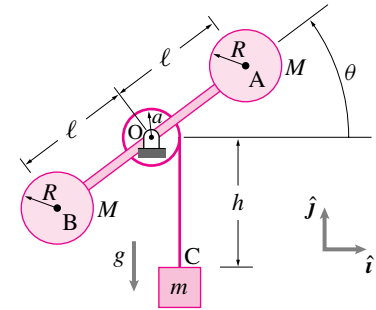

Filename:s97p3-1

13.154 Two racks connected by a gear. A 100 lbf force is applied to one rack. At the output the machinery (not shown) applies a force F_B to the other rack.

- Assume the gear is spinning at constant rate and is frictionless. What is F_B ?
- If the gear bearing had friction, would that increase or decrease F_B to achieve the same constant rate?
- If the angular velocity of the gear is increasing at rate α , does this increase or decrease F_B at the given ω .
- If the output load F_B is given then the motion of the machine can be found from the input load. Assume that the machine starts from rest with a given output load. So long as rack B moves in the opposite direction of the output force F_B the output power is positive.

- For what values of F_B is the output power positive?
- For what values of F_B is the output work maximum if the machine starts from rest and runs for a fixed amount of time?

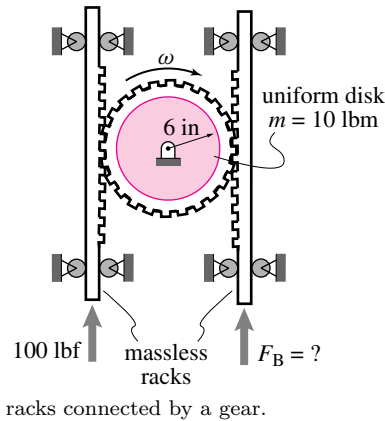

Filename:pg131-1

all of m , R , ℓ , θ_0 , k , \hat{i} , and \hat{j} . [Hint: There are several steps of reasoning required. You might want to draw FBD(s), use angular momentum balance, set up a differential equation, solve it, plug values into this solution, and use the result to find the quantities of interest.]

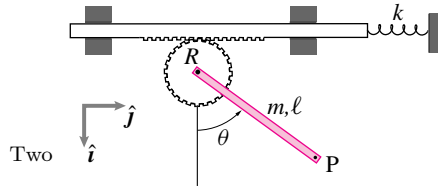

Filename:p-f96-p2-2

13.155 2-D accelerating gear train. Assume you know the torque $M_{\text{input}} = M_A$ and angular velocity $\omega_{\text{input}} = \omega_A$ of the input shaft. Assume the bearings and contacts are frictionless. Assume you also know the input angular acceleration $\dot{\omega}$ and the moments of inertia I_A , I_B and I_C of each of the disks about their centers.

- What is the input power?
- What is the output power?
- What is the angular velocity $\omega_{\text{output}} = \omega_C$ of the output shaft?
- What is the output torque $M_{\text{output}} = M_C$?

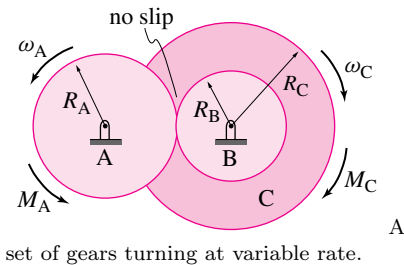

Filename:pg129-1

13.156 A stick welded to massless gear that rolls against a massless rack which slides on frictionless bearings and is constrained by a linear spring. Neglect gravity. The spring is relaxed when the angle $\theta = 0$. Assume the system is released from rest at $\theta = \theta_0$. What is the acceleration of the point P at the end of the stick when $\theta = 0$? Answer in terms of any or

13.157 A tipped hanging sign is represented by a point mass m . The sign sits at the end of a massless, rigid rod which is hinged at its point of attachment to the ground. A taut massless elastic cord helps keep the rod vertical. The tension T in the very stretchy cord is idealized as constant during small displacements. (Note also that $\phi \equiv \theta$ during such motions). Consider all hinges to be frictionless and motions to take place in the plane of the paper.

- Write the angular momentum of the mass about 0 when the rod has an angular velocity θ .
- Find the differential equation that governs the mass's motion for small θ .
- Describe the motion for $T > \frac{mg}{2}$, $T = \frac{mg}{2}$, and $T < \frac{mg}{2}$. Interpret the differences of these cases in physical terms.

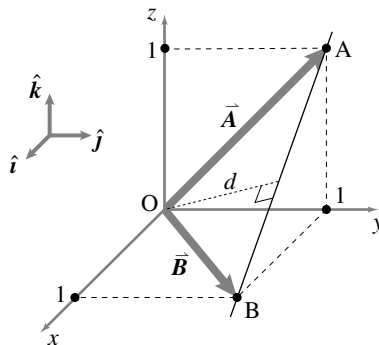

Filename:pfigure-blue-1-3